



---

# Penguin Edge™ MVME7100ET

Installation and Use

P/N: 6806800K87H

July 2022

---



## Legal Disclaimer\*

SMART Embedded Computing, Inc. (SMART EC), dba Penguin Solutions™, assumes no responsibility for errors or omissions in these materials. **These materials are provided "AS IS" without warranty of any kind, either expressed or implied, including but not limited to, the implied warranties of merchantability, fitness for a particular purpose, or non-infringement.** SMART EC further does not warrant the accuracy or completeness of the information, text, graphics, links, or other items contained within these materials. SMART EC shall not be liable for any special, indirect, incidental, or consequential damages, including without limitation, lost revenues or lost profits, which may result from the use of these materials. SMART EC may make changes to these materials, or to the products described therein, at any time without notice. SMART EC makes no commitment to update the information contained within these materials.

Electronic versions of this material may be read online, downloaded for personal use, or referenced in another document as a URL to a SMART EC website. The text itself may not be published commercially in print or electronic form, edited, translated, or otherwise altered without the permission of SMART EC.

It is possible that this publication may contain reference to or information about SMART EC products, programming, or services that are not available in your country. Such references or information must not be construed to mean that SMART EC intends to announce such SMART EC products, programming, or services in your country.

## Limited and Restricted Rights Legend

If the documentation contained herein is supplied, directly or indirectly, to the U.S. Government, the following notice shall apply unless otherwise agreed to in writing by SMART EC.

Use, duplication, or disclosure by the Government is subject to restrictions as set forth in subparagraph (b)(3) of the Rights in Technical Data clause at DFARS 252.227-7013 (Nov. 1995) and of the Rights in Noncommercial Computer Software and Documentation clause at DFARS 252.227-7014 (Jun. 1995).

### **SMART Embedded Computing, Inc., dba Penguin Solutions**

2900 S. Diablo Way, Suite 190

Tempe, Arizona 85282

USA

\*For full legal terms and conditions, visit <https://www.penguinsolutions.com/edge/legal/>

# Table of Contents

---

About this Manual .....	11
Safety Notes .....	17
Sicherheitshinweise .....	21
<b>1 Introduction .....</b>	<b>25</b>
1.1 Features .....	25
1.2 Standard Compliances .....	27
1.3 Mechanical Data .....	28
1.4 Ordering Information .....	28
<b>2 Hardware Preparation and Installation .....</b>	<b>29</b>
2.1 Overview .....	29
2.2 Unpacking and Inspecting the Board .....	30
2.3 Requirements .....	30
2.3.1 Environmental Requirements .....	31
2.3.2 Power Requirements .....	32
2.3.3 Thermal Requirements .....	32
2.3.4 Thermally Significant Components .....	33
2.3.5 Equipment Requirements .....	35
2.4 Configuring the Board .....	35
2.4.1 SMT Configuration Switch, S1 .....	37
2.4.1.1 Safe Start Switch .....	38
2.4.1.2 Boot Block B Select .....	38
2.4.1.3 Flash Bank Write Protect .....	38
2.4.1.4 JTAG Pass-Thru .....	38
2.4.1.5 Low Memory Offset .....	39
2.4.1.6 PMC 133 MHz .....	39
2.4.1.7 Master WP .....	39
2.4.2 Geographical Address Switch, S2 .....	39
2.4.3 VME System Controller Select, S2 .....	40
2.5 Installing Accessories .....	40
2.5.1 Transition Module .....	40
2.5.2 PMC .....	42

# Table of Contents

---

2.5.3	XMCspan	43
2.6	Installing and Removing the Board	44
2.7	Completing the Installation	45
2.8	Factory Installed Linux	45
<b>3</b>	<b>Controls, LEDs, and Connectors</b>	<b>47</b>
3.1	Overview	47
3.2	Board Layout	47
3.3	Front Panel	48
3.3.1	Reset/Abort Switch	48
3.3.2	LEDs	49
3.3.3	Connectors	49
3.3.3.1	XMC Expansion Connector (J6)	51
3.3.3.2	Ethernet Connectors (J4A/J4B)	53
3.3.3.3	PCI Mezzanine Card (PMC) Connectors (J11-J14, J21-J23)	53
3.3.3.4	Serial Port Connector (COM1/J1)	64
3.3.3.5	VMEbus P1 Connector	64
3.3.3.6	VMEbus P2 Connector	66
3.3.3.7	MVME721ET PMC I/O Module (PIM) Connectors (J10, J14)	67
3.4	Headers	69
3.4.1	Processor COP Header (P4)	69
3.4.2	Boundary Scan Header (P5)	70
<b>4</b>	<b>Functional Description</b>	<b>71</b>
4.1	Overview	71
4.2	Block Diagram	72
4.3	Processor	73
4.4	I2C Serial Interface and Devices	73
4.5	System Memory	74
4.6	Timers	74
4.7	Ethernet Interfaces	74
4.8	Local Bus Interface	74
4.8.1	Flash Memory	75
4.8.2	NVRAM	75
4.8.3	Quad UART (QUART)	75
4.8.4	Control and Timers PLD	76
4.9	DUART Interface	76

4.10	PCI-E Port 0	76
4.10.1	VME Controller	77
4.11	XMC Expansion	77
4.12	Power Supplies	77
4.12.1	Power Sequencing	77
4.12.2	Power Supply Monitor	77
4.12.3	Power Supply Filtering and Fusing	78
4.13	Clock Distribution	78
4.13.1	System Clock	78
4.13.2	Real Time Clock Input	78
4.13.3	Local Bus Controller Clock Divisor	78
4.14	Reset Control Logic	79
4.15	Real Time Clock Battery	79
<b>5</b>	<b>Transition Module</b>	<b>81</b>
5.1	Overview	81
5.2	Transition Module Layout	81
5.3	Features	82
5.4	SEEPROM Address Switch, S1	83
5.5	Rear Panel Connectors	84
5.6	PMC Input/Output Module	85
<b>6</b>	<b>MOTLoad Firmware</b>	<b>89</b>
6.1	Overview	89
6.2	Implementation and Memory Requirements	89
6.3	MOTLoad Commands	89
6.3.1	Utilities	89
6.3.2	Tests	90
6.3.3	Command List	91
6.4	Using the Command Line Interface	96
6.4.1	Rules	97
6.4.2	Help	98
6.5	Firmware Settings	99
6.5.1	Default VME Settings	99
6.5.2	Control Register/Control Status Register Settings	102
6.5.3	Displaying VME Settings	102
6.5.4	Editing VME Settings	103

# Table of Contents

---

6.5.5	Deleting VME Settings	103
6.5.6	Restoring Default VME Settings	104
6.6	Remote Start	104
6.7	Boot Images	105
6.7.1	Checksum Algorithm	106
6.7.2	Image Flags	106
6.7.3	User Images	107
6.7.4	Alternate Boot Data Structure	108
6.7.5	Alternate Boot Images and Safe Start	108
6.7.6	Boot Image Firmware Scan	108
6.8	Startup Sequence	110
<b>A</b>	<b>Battery Exchange</b>	<b>111</b>
A.1	Battery Exchange	111
<b>B</b>	<b>Related Documentation</b>	<b>113</b>
B.1	Penguin Solutions Documentation	113
B.2	Manufacturers' Documents	113
B.3	Related Specifications	115

# List of Figures

---

Figure 2-1	Primary Side Thermally Significant Components . . . . .	34
Figure 2-2	Secondary Side Thermally Significant Components . . . . .	35
Figure 2-3	Switch Locations . . . . .	36
Figure 2-4	SMT Configuration Switch Position . . . . .	37
Figure 2-5	Geographical Address Switch Position . . . . .	39
Figure 2-6	Typical Placement of a PMC Module on a VME Module . . . . .	43
Figure 3-1	Component Layout . . . . .	47
Figure 3-2	Front Panel LEDs, Connectors, Switch . . . . .	48
Figure 4-1	Block Diagram . . . . .	72
Figure 5-1	Component Layout . . . . .	81
Figure 5-2	Block Diagram . . . . .	82
Figure 5-3	S1 Switch Positions . . . . .	83
Figure 5-4	Rear Panel Connectors and LEDs . . . . .	85
Figure 5-5	Installing the PIM . . . . .	87
Figure A-1	Battery Location . . . . .	111

## List of Figures

---



# List of Tables

---

Table 1-1	Features List . . . . .	25
Table 1-2	Board Standard Compliances . . . . .	27
Table 1-3	Mechanical Data . . . . .	28
Table 2-1	Startup Overview . . . . .	29
Table 2-2	MVME7100ET Specifications . . . . .	31
Table 2-3	Power Requirements . . . . .	32
Table 2-4	Thermally Significant Components . . . . .	33
Table 2-5	Configuration Switch Settings (S1) . . . . .	37
Table 2-6	VME System Controller and GA Switch Settings . . . . .	40
Table 3-1	Front Panel LEDs . . . . .	49
Table 3-2	Baseboard Connectors . . . . .	50
Table 3-3	XMC Expansion Connector (J6) Pin Assignments . . . . .	51
Table 3-4	Ethernet Connectors (J4A/J4B) Pin Assignments . . . . .	53
Table 3-5	PMC Slot 1 Connector (J11) Pin Assignments . . . . .	53
Table 3-6	PMC Slot 1 Connector (J12) Pin Assignments . . . . .	55
Table 3-7	PMC Slot 1 Connector (J13) Pin Assignments . . . . .	56
Table 3-8	PMC Slot 1 Connector (J14) Pin Assignments . . . . .	58
Table 3-9	PMC Slot 2 Connector (J21) Pin Assignments . . . . .	59
Table 3-10	PMC Slot 2 Connector (J22) Pin Assignments . . . . .	61
Table 3-11	PMC Slot 2 Connector (J23) Pin Assignments . . . . .	62
Table 3-12	COM1 Port Connector Pin Assignments . . . . .	64
Table 3-13	VMEbus P1 Connector Pin Assignments . . . . .	64
Table 3-14	VME P2 Connector Pinouts . . . . .	66
Table 3-15	MVME721ET Host I/O Connector (J10) Pin Assignments . . . . .	67
Table 3-16	Processor COP Header (P4) Pin Assignments . . . . .	69
Table 3-17	Boundary Scan Header (P5) Pin Assignments . . . . .	70
Table 4-1	Clock Frequencies . . . . .	78
Table 5-1	Transition Module Features . . . . .	82
Table 5-2	SEEPROM Address Switch Assignments (RTM) . . . . .	83
Table 5-3	Switch Settings and Device Addresses . . . . .	83
Table 5-4	Transition Module Connectors . . . . .	84
Table 5-5	Transition Module LEDs . . . . .	85
Table 6-1	MOTLoad Commands . . . . .	91
Table 6-2	MOTLoad Image Flags . . . . .	106
Table B-1	Penguin Solutions Documentation . . . . .	113
Table B-2	Manufacturer's Publications . . . . .	113
Table B-3	Related Specifications . . . . .	115

## List of Tables

---

# About this Manual

---

## Overview of Contents

This manual provides the information required to install and configure an MVME7100ET Single Board Computer. Additionally, this manual provides specific preparation and installation information and data applicable to the board.

The MVME7100ET is a high-performance, dual core processor board featuring the NXP 8641D with a dedicated bridge to each processor.

This manual is divided into the following chapters and appendices:

*Safety Notes on page 17* summarizes the safety instructions in the manual.

*Sicherheitshinweise on page 21* is a German translation of the Safety Notes chapter.

*Chapter 1, Introduction on page 25* lists the features of the MVME7100ET baseboard, standard compliances, and model numbers for boards and accessories.

*Chapter 2, Hardware Preparation and Installation on page 29* includes a description of the MVME7100ET, unpacking instructions, environmental, thermal, and power requirements, and how to prepare and install the baseboard, transition module, and PMC module.

*Chapter 3, Controls, LEDs, and Connectors on page 47* provides an illustration of the board components and front panel details.

*Chapter 4, Functional Description on page 71* describes the major features of the MVME7100ET baseboard. These descriptions include both programming and hardware characteristics of major components.

*Chapter 5, Transition Module on page 81* describes the MVME721ET transition module used with the MVME7100ET.

*Chapter 6, MOTLoad Firmware on page 89* describes the role, process, and commands employed by the MVME7100ET diagnostic and initialization firmware MOTLoad. This chapter also briefly describes how to use the debugger commands.

*Appendix A, Battery Exchange on page 111* describes the procedure for replacing a battery.

*Appendix B, Related Documentation on page 113* provides listings for publications, manufacturer's documents and related industry specification for this product.

# Abbreviations



This document uses the following abbreviations:





<b>TERM</b>	<b>MEANING</b>
A	Amps
ANSI	American National Standard Institute
BLT	Block Transfer
CFM	Cubic Feet per Minute
CMC	Common Mezzanine Card
COM	Communications
COP	Common On-chip Processor
DDR	Double Data Rate
DMA	Direct Memory Access
DUART	Dual Universal Asynchronous Receiver/Transmitter
ECC	Error Correction Code
EEPROM	Electrically Erasable Programmable Read-Only Memory
FCC	Federal Communications Commission
FIFO	First In First Out
Gbps	Gigabits Per Second
GPCM	General Purpose Chip select Machine
IEEE	Institute of Electrical and Electronics Engineers
I2C	Inter IC
JTAG	Joint Test Access Group
KBAUD	Kilo Baud
LBC	Local Bus Controller
NAND	(Not and) Flash that is used for storage
NOR	(Not or) Flash that is used for executing code
PCI-X	Peripheral Component Interconnect -X
PIC	Programmable Interrupt Controller

<b>TERM</b>	<b>MEANING</b>
PIM	PCI Mezzanine Card Input/Output Module
PMC	PCI Mezzanine Card (IEEE P1386.1)
PLD	Programmable Logic Device
QUART	Quad Universal Asynchronous Receiver/Transmitter
RGMII	Reduced Gigabit Media Independent Interface
RTC	Real-Time Clock
RTM	Rear Transition Module
SBC	Single Board Computer
SDRAM	Synchronous Dynamic Random Access Memory
SMT	Surface Mount Technology
SODIMM	Small-Outline Dual In-line Memory Module
SPD	Serial Presence Detect
SRAM	Static Random Access Memory
TSEC	Three-Speed Ethernet Controller
2eSST	Two edge Source Synchronous Transfer
UART	Universal Asynchronous Receiver/Transmitter
V	Volts
VIO	Input/Output Voltage
VITA	VMEbus International Trade Association
VME	VMEbus (Versa Module Eurocard)
VPD	Vital Product Data
W	Watts

# Conventions

The following table describes the conventions used throughout this manual:

Notation	Description
0x00000000	Typical notation for hexadecimal numbers (digits are 0 through F), for example used for addresses and offsets
0b0000	Same for binary numbers (digits are 0 and 1)
<b>bold</b>	Used to emphasize a word
Screen	Used for on-screen output and code related elements or commands. Sample of Programming used in a table (9pt)
<b>Courier + Bold</b>	Used to characterize user input and to separate it from system output
<i>Reference</i>	Used for references and for table and figure descriptions
File > Exit	Notation for selecting a submenu
<text>	Notation for variables and keys
[text]	Notation for software buttons to click on the screen and parameter description
...	Repeated item for example node 1, node 2, ..., node 12
.	Omission of information from example/command that is not necessary at the time
..	Ranges, for example: 0..4 means one of the integers 0,1,2,3, and 4 (used in registers)
	Logical OR
	Indicates a hazardous situation which, if not avoided, could result in death or serious injury
	Indicates a hazardous situation which, if not avoided, may result in minor or moderate injury

Notation	Description
	Indicates a property damage message
	Indicates a hot surface that could result in moderate or serious injury
	Indicates an electrical situation that could result in moderate injury or death
<p>Use ESD protection</p> 	Indicates that when working in an ESD environment care should be taken to use proper ESD practices
	No danger encountered, pay attention to important information

## Summary of Changes

This manual has been revised and replaces all prior editions.

Part Number	Publication Date	Description
6806800K87H	July 2022	Rebrand to Penguin Solutions.
6806800K87G	October 2019	Rebrand to SMART Embedded Computing Template. Updated Freescale to NXP; updated RoHS compliance
6806800K87F	May 2016	Removed <i>Declaration of Conformity</i> .
6806800K87E	June 2014	Rebrand to Artesyn template.
6806800K87D	December 2012	Updated <a href="#">Standard Compliances on page 27</a> .

## About this Manual

---

<b>Part Number</b>	<b>Publication Date</b>	<b>Description</b>
6806800K87C	September 2011	Updated <i>Safety Notes on page 17</i> and <i>Sicherheitshinweise on page 21</i> .
6806800K87B	July 2011	Updated <i>MVME7100ET Specifications on page 31</i> .
6806800K87A	September 2010	First edition



# Safety Notes

---

This section provides warnings that precede potentially dangerous procedures throughout this manual. Instructions contained in the warnings must be followed during all phases of operation, service, and repair of this equipment. You should also employ all other safety precautions necessary for the operation of the equipment in your operating environment. Failure to comply with these precautions or with specific warnings elsewhere in this manual could result in personal injury or damage to the equipment.

Penguin Solutions™ intends to provide all necessary information to install and handle the product in this manual. Because of the complexity of this product and its various uses, we do not guarantee that the given information is complete. If you need additional information, ask your Penguin Solutions representative.

This product is a Safety Extra Low Voltage (SELV) device designed to meet the EN60950-1 requirements for Information Technology Equipment. The use of the product in any other application may require safety evaluation specific to that application.

Only personnel trained by Penguin Solutions or persons qualified in electronics or electrical engineering are authorized to install, remove or maintain the product.

The information given in this manual is meant to complete the knowledge of a specialist and must not be used as replacement for qualified personnel.

Keep away from live circuits inside the equipment. Operating personnel must not remove equipment covers. Only Factory Authorized Service Personnel or other qualified service personnel may remove equipment covers for internal subassembly or component replacement or any internal adjustment.

Do not install substitute parts or perform any unauthorized modification of the equipment or the warranty may be voided. Contact your local Penguin Solutions representative for service and repair to make sure that all safety features are maintained.

## EMC

This equipment has been tested and found to comply with the limits for a Class A digital device, pursuant to Part 15 of the FCC Rules. These limits are designed to provide reasonable protection against harmful interference when the equipment is operated in a commercial environment. This equipment generates, uses, and can radiate radio frequency energy and, if not installed and used in accordance with the instruction manual, may cause harmful interference to radio communications.

Operation of this equipment in a residential area is likely to cause harmful interference in which case the user will be required to correct the interference at his own expense. Changes or modifications not expressly approved by Penguin Solutions could void the user's authority to operate the equipment. Board products are tested in a representative

---

system to show compliance with the above mentioned requirements. A proper installation in a compliant system will maintain the required performance. Use only shielded cables when connecting peripherals to assure that appropriate radio frequency emissions compliance is maintained.

## Operation

### **Product Damage**

High humidity and condensation on the board surface causes short circuits.

Do not operate the board outside the specified environmental limits.

Make sure the board is completely dry and there is no moisture on any surface before applying power.

### **Damage of Circuits**

Electrostatic discharge and incorrect installation and removal can damage circuits or shorten their life.

Before touching the board or electronic components, make sure that you are working in an ESD-safe environment.

### **Board Malfunction**

Switches marked as “reserved” might carry production-related functions and can cause the board to malfunction if their setting is changed.

Do not change settings of switches marked as “reserved”. The setting of switches which are not marked as “reserved” has to be checked and changed before board installation.

## Installation

### **Data Loss**

Powering down or removing a board before the operating system or other software running on the board has been properly shut down may cause corruption of data or file systems.

Make sure all software is completely shut down before removing power from the board or removing the board from the chassis.

### **Product Damage**

Only use injector handles for board insertion to avoid damage to the front panel and/or PCB. Deformation of the front panel can cause an electrical short or other board malfunction.

---

### **Product Damage**

Inserting or removing modules with power applied may result in damage to module components.

Before installing or removing additional devices or modules, read the documentation that came with the product.

## **Cabling and Connectors**

### **Product Damage**

RJ-45 connectors on modules are either twisted-pair Ethernet (TPE) or E1/T1/J1 network interfaces. Connecting an E1/T1/J1 line to an Ethernet connector may damage your system.

- Make sure that TPE connectors near your working area are clearly marked as network connectors.
- Verify that the length of an electric cable connected to a TPE bushing does not exceed 100 meters.
- Make sure the TPE bushing of the system is connected only to safety extra low voltage circuits (SELV circuits).

If in doubt, ask your system administrator.

## **Battery**

### **Board/System Damage**

Incorrect exchange of lithium batteries can result in a hazardous explosion. When exchanging the on-board lithium battery, make sure that the new and the old battery are from exactly the same battery manufacturer and of the same models. If the respective battery model is not available, contact your local Penguin Solutions sales representative for the availability of alternative, officially approved battery models.

### **Data Loss**

Exchanging the battery can result in loss of time settings. Backup power prevents the loss of data during exchange.

Quickly replacing the battery may save time settings.

### **Data Loss**

If the battery has low or insufficient power the RTC is initialized.

Exchange the battery before seven years of actual battery use have elapsed.

---

### **PCB and Battery Holder Damage**

Removing the battery with a screw driver may damage the PCB or the battery holder. To prevent damage, do not use a screw driver to remove the battery from its holder.

# Sicherheitshinweise

---

Dieses Kapitel enthält Hinweise, die potentiell gefährlichen Prozeduren innerhalb dieses Handbuchs vorrangestellt sind. Beachten Sie unbedingt in allen Phasen des Betriebs, der Wartung und der Reparatur des Systems die Anweisungen, die diesen Hinweisen enthalten sind. Sie sollten außerdem alle anderen Vorsichtsmaßnahmen treffen, die für den Betrieb des Produktes innerhalb Ihrer Betriebsumgebung notwendig sind. Wenn Sie diese Vorsichtsmaßnahmen oder Sicherheitshinweise, die an anderer Stelle dieses Handbuchs enthalten sind, nicht beachten, kann das Verletzungen oder Schäden am Produkt zur Folge haben.

Penguin Solutions™ ist darauf bedacht, alle notwendigen Informationen zum Einbau und zum Umgang mit dem Produkt in diesem Handbuch bereit zu stellen. Da es sich jedoch um ein komplexes Produkt mit vielfältigen Einsatzmöglichkeiten handelt, können wir die Vollständigkeit der im Handbuch enthaltenen Informationen nicht garantieren. Falls Sie weitere Informationen benötigen sollten, wenden Sie sich bitte an die für Sie zuständige Geschäftsstelle von Penguin Solutions.

Das Produkt wurde entwickelt, um die Sicherheitsanforderungen für SELV Geräte nach der Norm EN 60950-1 für informationstechnische Einrichtungen zu erfüllen. Die Verwendung des Produkts in einer anderen Anwendung erfordert eine Sicherheitsüberprüfung für diese spezifische Anwendung.

Einbau, Wartung und Betrieb dürfen nur von durch Penguin Solutions ausgebildetem oder im Bereich Elektronik oder Elektrotechnik qualifiziertem Personal durchgeführt werden. Die in diesem Handbuch enthaltenen Informationen dienen ausschließlich dazu, das Wissen von Fachpersonal zu ergänzen, können dieses jedoch nicht ersetzen.

Halten Sie sich von stromführenden Leitungen innerhalb des Produktes fern. Entfernen Sie auf keinen Fall Abdeckungen am Produkt. Nur werksseitig zugelassenes Wartungspersonal oder anderweitig qualifiziertes Wartungspersonal darf Abdeckungen entfernen, um Komponenten zu ersetzen oder andere Anpassungen vorzunehmen.

Installieren Sie keine Ersatzteile oder führen Sie keine unerlaubten Veränderungen am Produkt durch, sonst verfällt die Garantie. Wenden Sie sich für Wartung oder Reparatur bitte an die für Sie zuständige Geschäftsstelle von Penguin Solutions. So stellen Sie sicher, dass alle sicherheitsrelevanten Aspekte beachtet werden.

## EMV

Das Produkt wurde in einem Penguin Edge™ Standardsystem getestet. Es erfüllt die für digitale Geräte der Klasse A gültigen Grenzwerte in einem solchen System gemäß den FCC-Richtlinien Abschnitt 15 bzw. EN 55022 Klasse A. Diese Grenzwerte sollen einen angemessenen Schutz vor Störstrahlung beim Betrieb des Produktes in Gewerbe- sowie Industriegebieten gewährleisten.

---

Das Produkt arbeitet im Hochfrequenzbereich und erzeugt Störstrahlung. Bei unsachgemäßem Einbau und anderem als in diesem Handbuch beschriebenen Betrieb können Störungen im Hochfrequenzbereich auftreten.

Wird das Produkt in einem Wohngebiet betrieben, so kann dies mit grosser Wahrscheinlichkeit zu starken Störungen führen, welche dann auf Kosten des Produkthanwenders beseitigt werden müssen. Änderungen oder Modifikationen am Produkt, welche ohne ausdrückliche Genehmigung von Penguin Solutions durchgeführt werden, können dazu führen, dass der Anwender die Genehmigung zum Betrieb des Produktes verliert. Boardprodukte werden in einem repräsentativen System getestet, um zu zeigen, dass das Board den oben aufgeführten EMV-Richtlinien entspricht. Eine ordnungsgemässe Installation in einem System, welches die EMV-Richtlinien erfüllt, stellt sicher, dass das Produkt gemäss den EMV-Richtlinien betrieben wird. Verwenden Sie nur abgeschirmte Kabel zum Anschluss von Zusatzmodulen. So ist sichergestellt, dass sich die Aussendung von Hochfrequenzstrahlung im Rahmen der erlaubten Grenzwerte bewegt.

Warnung! Dies ist eine Einrichtung der Klasse A. Diese Einrichtung kann im Wohnbereich Funkstörungen verursachen. In diesem Fall kann vom Betreiber verlangt werden, angemessene Maßnahmen durchzuführen.

## Betrieb

### **Beschädigung des Produktes**

Hohe Luftfeuchtigkeit und Kondensat auf der Oberfläche des Produktes können zu Kurzschlüssen führen.

Betreiben Sie das Produkt nur innerhalb der angegebenen Grenzwerte für die relative Luftfeuchtigkeit und Temperatur. Stellen Sie vor dem Einschalten des Stroms sicher, dass sich auf dem Produkt kein Kondensat befindet.

### **Beschädigung von Schaltkreisen**

Elektrostatische Entladung und unsachgemäßer Ein- und Ausbau des Produktes kann Schaltkreise beschädigen oder ihre Lebensdauer verkürzen.

Bevor Sie das Produkt oder elektronische Komponenten berühren, vergewissern Sie sich, daß Sie in einem ESD-geschützten Bereich arbeiten.

### **Fehlfunktion des Produktes**

Schalter, die mit 'Reserved' gekennzeichnet sind, können mit produktionsrelevanten Funktionen belegt sein. Das Ändern dieser Schalter kann im normalen Betrieb Störungen auslösen.

Verstellen Sie nur solche Schalter, die nicht mit 'Reserved' gekennzeichnet sind. Prüfen und ggf. ändern Sie die Einstellungen der nicht mit 'Reserved' gekennzeichneten Schalter, bevor Sie das Produkt installieren.

---

## Installation

### **Datenverlust**

Das Herunterfahren oder die Deinstallation eines Boards bevor das Betriebssystem oder andere auf dem Board laufende Software ordnungsmässig beendet wurde, kann zu partiellem Datenverlust sowie zu Schäden am Filesystem führen.

Stellen Sie sicher, dass sämtliche Software auf dem Board ordnungsgemäss beendet wurde, bevor Sie das Board herunterfahren oder das Board aus dem Chassis entfernen.

### **Beschädigung des Produktes**

Fehlerhafte Installation des Produktes kann zu einer Beschädigung des Produktes führen.

Verwenden Sie die Handles, um das Produkt zu installieren/deinstallieren. Auf diese Weise vermeiden Sie, dass das Face Plate oder die Platine deformiert oder zerstört wird.

### **Beschädigung des Produktes und von Zusatzmodulen**

Fehlerhafte Installation von Zusatzmodulen, kann zur Beschädigung des Produktes und der Zusatzmodule führen.

Lesen Sie daher vor der Installation von Zusatzmodulen die zugehörige Dokumentation.

## Kabel und Stecker

### **Beschädigung des Produktes**

Bei den RJ-45-Steckern, die sich an dem Produkt befinden, handelt es sich entweder um Twisted-Pair-Ethernet (TPE) oder um E1/T1/J1-Stecker. Beachten Sie, dass ein versehentliches Anschließen einer E1/T1/J1-Leitung an einen TPE-Stecker das Produkt zerstören kann.

- Kennzeichnen Sie deshalb TPE-Anschlüsse in der Nähe Ihres Arbeitsplatzes deutlich als Netzwerkanschlüsse.
- Stellen Sie sicher, dass die Länge eines mit Ihrem Produkt verbundenen TPE-Kabels 100 m nicht überschreitet.
- Das Produkt darf über die TPE-Stecker nur mit einem Sicherheits-Kleinspannungs-Stromkreis (SELV) verbunden werden.

Bei Fragen wenden Sie sich an Ihren Systemverwalter.

---

## Batterie

### **Beschädigung des Blades**

Ein unsachgemäßer Einbau der Batterie kann gefährliche Explosionen und Beschädigungen des Blades zur Folge haben.

Verwenden Sie deshalb nur den Batterietyp, der auch bereits eingesetzt wurde und befolgen Sie die Installationsanleitung.

### **Datenverlust**

Wenn Sie die Batterie austauschen, können die Zeiteinstellungen verloren gehen. Eine Backupversorgung verhindert den Datenverlust während des Austauschs.

Wenn Sie die Batterie schnell austauschen, bleiben die Zeiteinstellungen möglicherweise erhalten.

### **Datenverlust**

Wenn die Batterie wenig oder unzureichend mit Spannung versorgt wird, wird der RTC initialisiert.

Tauschen Sie die Batterie aus, bevor sieben Jahre tatsächlicher Nutzung vergangen sind.

### **Schäden an der Platine oder dem Batteriehalter**

Wenn Sie die Batterie mit einem Schraubendreher entfernen, können die Platine oder der Batteriehalter beschädigt werden.

Um Schäden zu vermeiden, sollten Sie keinen Schraubendreher zum Ausbau der Batterie verwenden.

## Umweltschutz

Entsorgen Sie alte Batterien und/oder Blades/Systemkomponenten/RTMs stets gemäß der in Ihrem Land gültigen Gesetzgebung, wenn möglich immer umweltfreundlich.



# Introduction

## 1.1 Features

The MVME7100ET is a VMEbus board based on the MC8640D and MC8641D integrated PowerPC processors. It is a full 6U board and occupies a single VME card slot with PMC cards installed. The MVME7100ET is compliant with the VITA standards VMEbus, 2eSST, and PCI-X as listed in [Appendix B, Related Documentation on page 113](#).

Table 1-1 Features List

Function	Features
Processor / Host Controller / Memory Controller	<ul style="list-style-type: none"> <li>One MC864xD Integrated Processor</li> <li>Two e600 cores with integrated L2</li> <li>Core frequency of 1.067 or 1.33GHz</li> <li>One integrated four channel DMA controller</li> <li>Two integrated PCIE interfaces</li> <li>Four integrated 10/100/1000 Ethernet controllers</li> <li>One integrated DUART</li> <li>Two integrated I<sup>2</sup>C controllers</li> <li>One integrated Programmable Interrupt Controller</li> <li>One integrated Local Bus Controller</li> <li>Two integrated DDR2 SDRAM controllers</li> </ul>
System Memory	<ul style="list-style-type: none"> <li>Two banks of DDR2 SDRAM with ECC</li> <li>2GB or 4GB</li> </ul>
I <sup>2</sup> C	<ul style="list-style-type: none"> <li>One 8KB VPD serial EEPROM</li> <li>Two 64KB user configuration serial EEPROMs</li> <li>One Real Time Clock (RTC) with removable battery</li> <li>Dual temperature sensor</li> <li>Two SPDs for memory</li> <li>Connection to XMCspan and rear transition module</li> </ul>
NOR Flash	<ul style="list-style-type: none"> <li>128MB soldered flash with two alternate 1 MB boot sectors selectable via hardware switch</li> <li>H/W switch or S/W bit write protection for entire logical bank</li> </ul>
NAND Flash	<ul style="list-style-type: none"> <li>Up to two devices available:               <ul style="list-style-type: none"> <li>4GB - 1 device</li> <li>8GB - 2 device</li> </ul> </li> </ul>
NVRAM	<ul style="list-style-type: none"> <li>One 512KB MRAM extended temperature range</li> <li>Two 64KB serial EEPROMs</li> </ul>

## Introduction

---

Table 1-1 Features List (continued)

Function	Features
PCI_E	8X Port to XMC Expansion 8X Port to 5 Port PCI Express switch
I/O	One front panel mini DB-9 connector for front I/O: one serial channel Two front panel RJ-45 connectors with integrated LEDs for front I/O: two 10/100/1000 Ethernet channels PMC site 1 front I/O and rear P2 I/O PMC site 2 front I/O
Ethernet	Four 10/100/1000 MC864xD Ethernet channels: two front panel Ethernet connectors and two channels for rear P2 I/O
Serial Interface	One 16550-compatible, 9.6 to 115.2 Kbaud, MC864xD, asynchronous serial channel: one channel for front panel I/O One quad UART (QUART) controller to provide four 16550-compatible, 9.6 to 115.2 Kbaud, asynchronous serial channels: four channels for rear P2 I/O
Timers	Four 32-bit MC864xD timers Four 32-bit timers in a PLD
Watchdog Timer	One watchdog timer in PLD
VME Interface	VME64 (ANSI/VITA 1-1994) compliant (3 row backplane 96-pin VME connector) VME64 Extensions (ANSI/VITA 1.1-1997) compliant (5 row backplane 160-pin VME connector) 2eSST (ANSI/VITA 1.5-2003) compliant Two five-row P1 and P2 backplane connectors One Tsi148 VMEbus controller
Form Factor	Standard 6U VME, one slot

Table 1-1 Features List (continued)

Function	Features
Miscellaneous	One front panel RESET/ABORT switch Six front panel status indicators: Two 10/100/1000 Ethernet link/speed and activity (4 total) Board fail User S/W controlled LED Planar status indicators One standard 16-pin JTAG/COP header Boundary scan support Switches for VME geographical addressing in a three-row backplane
Software Support	VxWorks OS support Linux OS support

## 1.2 Standard Compliances

The MVME7100ET is designed to be CE compliant and to meet the following requirements.

Table 1-2 Board Standard Compliances

Standard	Description
UL 60950-1 EN 60950-1 IEC 60950-1 CAN/CSA C22.2 No 60950-1	Safety Requirements (legal)
CISPR 22 CISPR 24 EN 55022 EN 55024 FCC Part 15 Industry Canada ICES-003 VCCI Japan AS/NZS CISPR 22 EN 300 386 NEBS Standard GR-1089 CORE	EMC requirements (legal) on system level (predefined Penguin Solutions system)
NEBS Standard GR-63-CORE ETSI EN 300 019 series	Environmental Requirements

## Introduction

---

Table 1-2 Board Standard Compliances (continued)

Standard	Description
Directive (EU) 2015/863 (amending Annex II to Directive 2011/65/EU)	Directive on the restriction of the use of certain hazardous substances in electrical and electronic equipment (RoHS)

## 1.3 Mechanical Data

This section provides details on the board's mechanical data.

Table 1-3 Mechanical Data

Characteristic	Value
Dimensions (D x W x H)	6U, 4HP wide, (233mm x 160mm x 20mm)
Weight	0.680kg

## 1.4 Ordering Information

Refer to the data sheet for the MVME7100ET for a complete list of available variants and accessories. Refer to [Appendix B, Related Documentation on page 113](#) or consult your local Penguin Solutions sales representative for the availability of other variants.

For technical assistance, documentation, or to report product damage or shortages, contact your local Penguin Solutions sales representative or visit <https://www.penguinsolutions.com/edge/support/>.

# Hardware Preparation and Installation

## 2.1 Overview

This chapter provides startup and safety instructions related to this product, hardware preparation instruction that includes default switch settings. System considerations and installation instructions for the baseboard, PMC, and transition module are also described in this chapter.

A fully implemented MVME7100ET consists of the baseboard plus:

- Two single-wide or one double-wide PCI Mezzanine Card (PMC) slot for added versatility.
- One transition module for support of the mapped I/O from the MVME7100ET baseboard to the P2 connector.
- Up to two optional XMCspan cards.

The following table lists the tasks that you are required to do before you can use this board. Read this entire chapter, including all Caution and Warning notes, before you begin.

*Table 2-1 Startup Overview*

<b>Task</b>	<b>Page</b>
Unpack the hardware	<a href="#">Unpacking and Inspecting the Board on page 30</a>
Configure the hardware by setting jumpers on the board and RTM	<a href="#">Configuring the Board on page 35</a> and <a href="#">SEEPROM Address Switch, S1 on page 83</a>
Install the MVME7216E transition module in the chassis	<a href="#">Transition Module on page 81</a>
Install PMC module (if required)	<a href="#">Installing Accessories on page 40</a>
Install XMCspan module (if required)	<a href="#">XMCspan Installation and Use (6806800H03)</a>
Install the MVME7100ET in the chassis	<a href="#">Installing and Removing the Board on page 44</a>
Attach cabling and apply power	<a href="#">Completing the Installation on page 45</a>
Install PIM on transition module (if required)	<a href="#">PMC Input/Output Module on page 85</a>
Ensure that the firmware initializes the MVME7100	<a href="#">MOTLoad Firmware on page 89</a>
Initialize the board	<a href="#">MOTLoad Firmware on page 89</a>

## Hardware Preparation and Installation

Table 2-1 Startup Overview (continued)

Task	Page
Examine and/or change environmental parameters	<i>MVME7100ET Single Board Computer Programmer's Reference</i>
Program the board as needed for your applications	<i>MVME7100ET Single Board Computer Programmer's Reference</i>

## 2.2 Unpacking and Inspecting the Board

Read all notices and cautions prior to unpacking the product.

### NOTICE

#### Damage of Circuits

**Electrostatic discharge and incorrect installation and removal can damage circuits or shorten their life.**

**Before touching the board or electronic components, make sure that you are working in an ESD-safe environment.**

### Shipment Inspection

To inspect the shipment, perform the following steps:

1. Verify that you have received all items of your shipment.
2. Check for damage and report any damage or differences to customer service.
3. Remove the desiccant bag shipped together with the board and dispose of it according to your country's legislation.



Important  
Information

**The product is thoroughly inspected before shipment. If any damage occurred during transportation or any items are missing, contact customer service immediately.**

## 2.3 Requirements

Make sure that the board, when operated in your particular system configuration, meets the requirements specified in the next sections.

## 2.3.1 Environmental Requirements

The following table lists the currently available specifications for the environmental characteristics of the MVME7100ET. A complete functional description of the MVME7100ET baseboard appears in [Chapter 4, Functional Description on page 71](#).



**Operating temperatures refer to the temperature of the air circulating around the board and not to the component temperature.**

Table 2-2 MVME7100ET Specifications

Characteristics	Operating
Cooling Method	Forced air
Operating temperature	-40°C to 71°C (-40°F to 160°F)
Storage Temperature	-50°C to +100°C
Temperature Transition Time	Operational temperature transition rate 0.5°C/minute
Vibration	Swept sine: 1.0g from 5.0 to 200Hz Sweep rate: 0.25 octaves/minute
Humidity	Designed to operate up to 100% relative humidity, Non condensing



**The RTC field removable battery should be removed, if MVME7100ET has to be stored beyond its operational temperature range.**

### NOTICE

#### Product Damage

**High humidity and condensation on the board surface causes short circuits.**

**Do not operate the board outside the specified environmental limits.**

**Make sure the board is completely dry and there is no moisture on any surface before applying power.**

## Hardware Preparation and Installation

### 2.3.2 Power Requirements

The MVME7100ET uses only +5.0V from the VMEbus backplane. On-board power supplies generate the required voltages for the various ICs. The MVME7100ET connects the +12V and -12V supplies from the backplane to the PMC sites while the +3.3V power supplied to the PMC sites comes from the +5.0V backplane power. A maximum of 10A of +3.3V power is available to the PMC sites, however the 90W +5.0V limit must be observed as well as any cooling limitations.

The table below provides an estimate of the typical and maximum power required.

Table 2-3 Power Requirements

Board Variant	Power
MVME7100ET-0161	Typical: 40W @ +5V Maximum: 55W @ +5V
MVME7100ET-0163	Typical: 40W @ +5V Maximum: 55W @ +5V
MVME7100ET-0171	Typical: 45W @ +5V Maximum: 60W @ +5V
MVME7100ET-0173	Typical: 45W @ +5V Maximum: 60W @ +5V

The following table shows the power available when the MVME7100ET is installed in either a 3-row or 5-row chassis and when PMCs are present.

Chassis Type	Available Power	Power With PMCs
3-Row	70W maximum	Below 70W <sup>1</sup>
5-Row	90W maximum	Below 90W <sup>1</sup>

1. Keep below power limit. Cooling limitations must be considered.

### 2.3.3 Thermal Requirements

The MVME7100ET module requires a minimum air flow of 10CFM uniformly distributed across the board, with the airflow traveling from the heat sink to the PMC2 site, when operating at a 55°C (131°F) ambient temperature.



### 2.3.4 Thermally Significant Components

The following table summarizes components that exhibit significant temperature rises. These are the components that should be monitored in order to assess thermal performance. The table also supplies the component reference designator and the maximum allowable operating temperature.

You can find components on the board by their reference designators as shown in [Figure 2-1](#) and [Figure 2-2](#). Versions of the board that are not fully populated may not contain some of these components.

The preferred measurement location for a component may be junction, case, or ambient as specified in the table below. Junction temperature refers to the temperature measured by an on-chip thermal device. Case temperature refers to the temperature at the top, center surface of the component. Air temperature refers to the ambient temperature near the component.

*Table 2-4 Thermally Significant Components*

<b>Reference Designator</b>	<b>Generic Description</b>	<b>Maximum Allowable Component Temperature</b>	<b>Measurement Location</b>
U27, U4	Gb Ethernet Transceiver	105°C	Ambient
U25, U26, U28	PCI-X/PCI-Express Bridge	85°C	Junction
U22	PCI-Express Bridge	115°C	Ambient
U24	VME Bridge	90°C	Junction
U10, U11, U12, U13, U14, U56, U57, U58, U59, U6, U60, U61, U62, U63, U64, U7, U8, U9	DDR2 SDRAM	95°C	Case
U20	MPU	105°C	Junction

# Hardware Preparation and Installation

Figure 2-1 Primary Side Thermally Significant Components

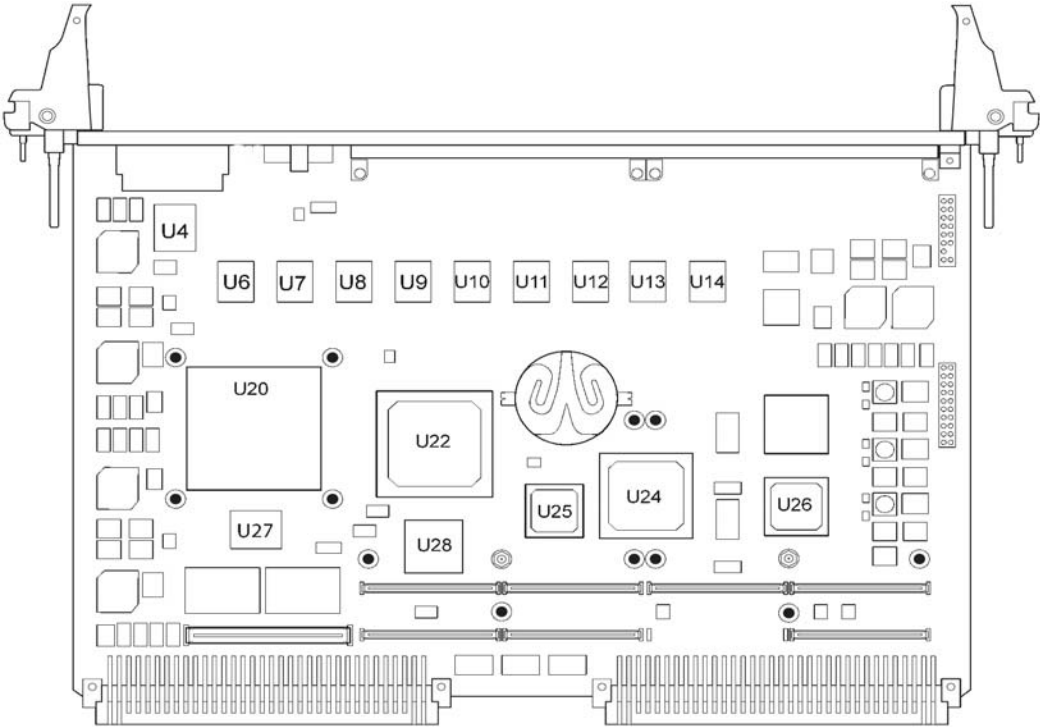
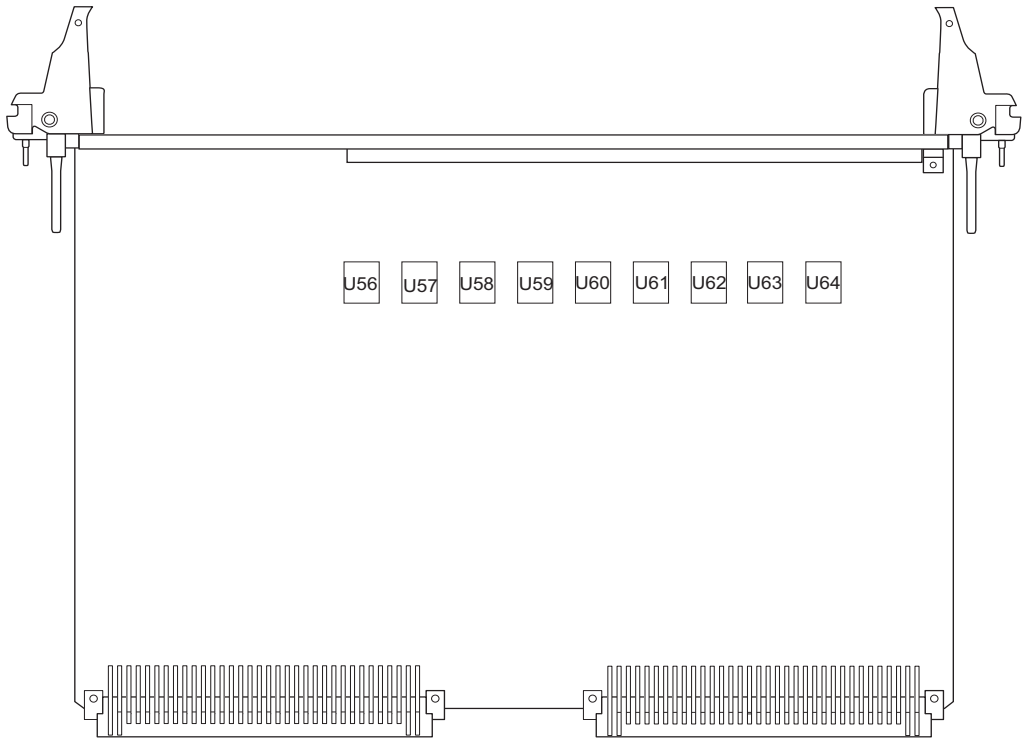

Figure 2-2 Secondary Side Thermally Significant Components



### 2.3.5 Equipment Requirements

The following equipments are recommended to complete an MVME7100ET system:

- VMEbus system enclosure
- System console terminal
- Operating system (and/or application software)
- Transition module and connecting cables

## 2.4 Configuring the Board

To produce the desired configuration and ensure proper operation of the MVME7100ET, you may need to carry out certain hardware modifications before installing the module.

## Hardware Preparation and Installation

The MVME7100ET provides software control over most options. By setting bits in control registers after installing the module in a system, you can modify its configuration. The MVME7100ET control registers are described in the *MVME7100ET Programmer's Reference*.

Prior to installing PMC modules on the MVME7100ET baseboard, ensure that all switches that are user configurable are set properly. To do this, refer to [Figure 2-3](#) or the board itself, for the location of specific switches and set the switches according to the following descriptions.

*Figure 2-3 Switch Locations*

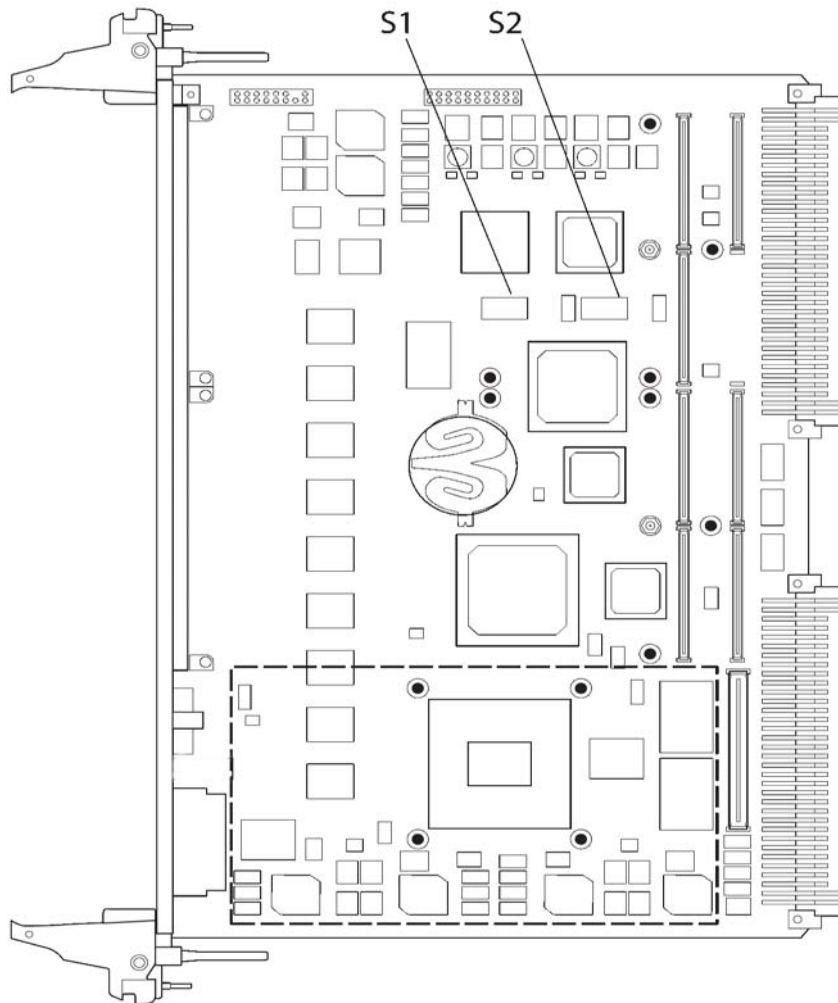

The following sections describe the on-board switches and their configurations for the MVME7100ET.

## NOTICE

### Board Malfunction

Switches marked as “reserved” might carry production-related functions and can cause the board to malfunction if their setting is changed.

Do not change settings of switches marked as “reserved”. The setting of switches which are not marked as “reserved” has to be checked and changed before board installation.

## 2.4.1 SMT Configuration Switch, S1

An 8-position SMT configuration switch (S1) is located on the MVME7100ET to control the flash bank write-protect, select the flash boot image, and control the safe start ENV settings. The default setting on all switch positions is OFF and is indicated by brackets in [Table 2-5](#).

Figure 2-4 SMT Configuration Switch Position

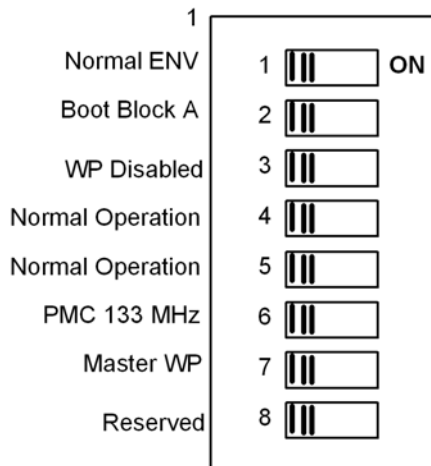

Table 2-5 Configuration Switch Settings (S1)

Switch	Description	Setting	Function
S1-1	Safe Start <sup>1</sup>	[OFF] ON	Use normal ENV Use safe ENV

## Hardware Preparation and Installation

Table 2-5 Configuration Switch Settings (S1) (continued)

Switch	Description	Setting	Function
S1-2	Boot Block B Select	[OFF] ON	Flash memory map normal and boot block A selected Boot block B selected, mapped to highest address
S1-3	Flash Bank WP	[OFF] ON	Entire flash not write-protected Flash is write-protected
S1-4	JTAG Pass Thru	[OFF] ON	Normal operation Pass-Thru mode
S1-5	CORE1 Low Memory Offset	[OFF] ON	Normal operation
S1-6	PMC 133 MHz	[OFF] ON	PMC 100 MHz maximum PMC 133 MHz maximum
S1-7	Master WP	[OFF] ON	Master write protect disabled Master write protect enabled
S1-8	Reserved		

1. Switch status is readable from System Status Register 1, bit 5.

### 2.4.1.1 Safe Start Switch

When the SAFE\_START switch is OFF, it indicates that the normal ENV setting should be used. When the switch is set to ON, GEVs, VPD, and SPD settings are ignored and known, safe, values are used.

### 2.4.1.2 Boot Block B Select

When the switch is OFF, the flash memory map is normal and block A is selected as shown in Figure 3. When the switch is ON, block B is mapped to the highest address.

### 2.4.1.3 Flash Bank Write Protect

When the FLASH BANK WP switch is OFF, it indicates that the entire NOR flash is not write-protected. NOR flash is used for executing code. When the switch is ON, it indicates that the flash is write-protected and any writes to the flash devices are blocked by hardware.

### 2.4.1.4 JTAG Pass-Thru

The JTAG Pass-Thru switch is in the OFF position for normal operation. The switch is ON for pass-through mode.

## 2.4.1.5 Low Memory Offset

The CORE1 Low Memory Offset switch is in the OFF position for normal operation. The switch is ON for enabling this feature.

## 2.4.1.6 PMC 133 MHz

The PMC 133MHz switch is OFF for normal operation. When the switch is ON, the maximum frequency of operation for the PMC sites is 133MHz. 133MHz operation should not be enabled unless the PMC modules are designed to support 133MHz operation. When the switch is OFF, the maximum frequency is 100MHz.

## 2.4.1.7 Master WP

The Master Write Protect (WP) switch is OFF for normal operation. When this switch is ON, writes to the NOR Flash, NAND Flash, MRAM and I<sup>2</sup>C EEPROMs are disabled. When the switch is OFF, writes to the non-volatile devices may be allowed depending on other switches and control bits.

## 2.4.2 Geographical Address Switch, S2

The Tsi148 VMEbus Status Register provides the VMEbus geographical address of the MVME7100ET. Applications not using the 5-row backplane can use the geographical address switch to assign a geographical address per the following diagram. More information regarding GA address switch assignments can be found in the *MVME7100ET Single Board Computer Programmer's Reference*.

Figure 2-5 Geographical Address Switch Position

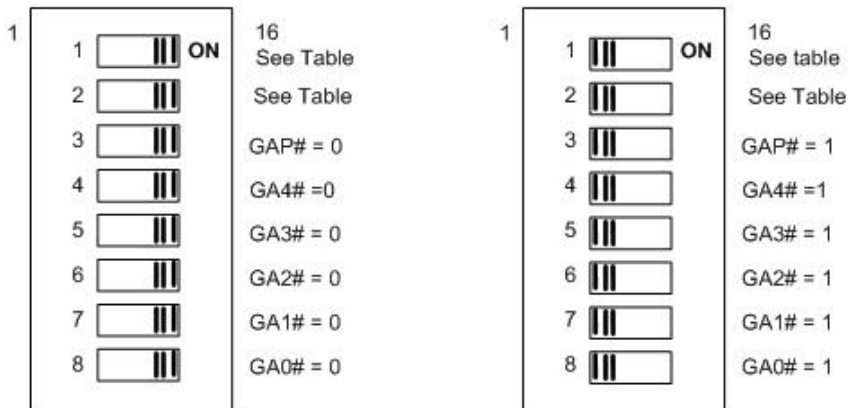

## Hardware Preparation and Installation

### 2.4.3 VME System Controller Select, S2

Positions 1 and 2 of S2 are used to select VME System Controller selection. The default is for automatic determination of SYSCON.

Table 2-6 VME System Controller and GA Switch Settings

Position	Function	Default
S2-1	VME SCON Auto <sup>1</sup>	Auto-SCON
S2-2	VME SCON SEL <sup>2</sup>	Non-SCON
S2-3	GAP	1
S2-4	GA4	1
S2-5	GA3	1
S2-6	GA2	1
S2-7	GA1	1
S2-8	GA0	1

1. The VME SCON MAN switch is OFF to select Auto-SCON mode. The switch is ON to select manual SCON mode which works in conjunction with the VME SCON SEL switch.

2. The VME SCON SEL switch is OFF to select non-SCON mode. The switch is ON to select always SCON mode. This switch is only effective when the VME SCON MAN switch is ON.

If you are installing the optional MVME7216E transition module, refer to [Chapter 5, Transition Module on page 81](#) for configuration switch settings.

## 2.5 Installing Accessories

This section describes the procedures for installing the MVME721ET transition module, PMCs, and the XMCspan on the baseboard.

### 2.5.1 Transition Module

The MVME721ET does not support hot swap, You should remove power to the rear slot or system before installing the module. Before installing the MVME721ET transition module, you may need to manually configure the switch and install a PMC I/O Module (PIM). Refer to [Chapter 5, Transition Module on page 81](#), for switch settings and PIM installation.



### **NOTICE**

#### **Damage of Circuits**

Electrostatic discharge and incorrect installation and removal can damage circuits or shorten their life.

Before touching the board or electronic components, make sure that you are working in an ESD-safe environment.

#### **Product Damage**

Only use injector handles for board insertion to avoid damage to the front panel and/or PCB. Deformation of the front panel can cause an electrical short or other board malfunction.

#### **Board Malfunction**

Switches marked as “reserved” might carry production-related functions and can cause the board to malfunction if their setting is changed.

Do not change settings of switches marked as “reserved”. The setting of switches which are not marked as “reserved” has to be checked and changed before board installation.

### **Installation and Removal Procedure**

To begin the installation of the transition module in a chassis, proceed as follows:

1. Turn all equipment power OFF and disconnect the power cable from the AC power source.
2. Remove the chassis cover as instructed in the equipment user's manual.
3. Remove the filler panel(s) from the appropriate card slot(s) at the rear of the chassis (if the chassis has a rear card cage).
4. Install the top and bottom edge of the transition module into the rear guides of the chassis.
5. Ensure that the levers of the two injector/ejectors are in the outward position.
6. Slide the transition module into the chassis until resistance is felt.
7. Simultaneously move the injector/ejector levers in an inward direction.
8. Verify that the transition module is properly seated and secure it to the chassis using the two screws located adjacent to the injector/ejector levers.
9. Connect the appropriate cables to the transition module.

To remove the transition module from the chassis, reverse the procedure and press the red locking tabs (IEEE handles only) to extract the board.

## Hardware Preparation and Installation

### 2.5.2 PMC

The PMC connectors are placed to support two single-width PMCs or one double-width PMC. PMC site 1 supports front PMC I/O and rear PMC I/O via the Jn4 connector. PMC 1 I/O is routed to the VME P2 connector. PMC site 2 only supports front PMC I/O and does not have a Jn4 connector. The PMC 1 Jn4 user I/O signals only support low-current high-speed signals and thus do not support current-bearing power supply usage.

In most cases, the PMCs are already in place on the baseboard. The user-configured switches are accessible with the PMCs installed. The on-board PMC sites are configured to support +3.3V I/O PMC modules. The onboard PMC sites do not support +5.0V I/O PMC modules.

Follow these steps to install a PMC onto the MVME7100ET board.

#### Installation Procedure

Read all notices and follow these steps to install a PMC on the baseboard.

### NOTICE

#### Damage of Circuits

**Electrostatic discharge and incorrect installation and removal can damage circuits or shorten their life.**

**Before touching the board or electronic components, make sure that you are working in an ESD-safe environment.**

#### Product Damage

**Inserting or removing modules with power applied may result in damage to module components.**

**Before installing or removing additional devices or modules, read the documentation that is provided with the product.**

1. Attach an ESD strap to your wrist. Attach the other end of the ESD strap to the chassis as a ground. The ESD strap must be secured to your wrist and to ground throughout the procedure.
2. Remove the PCI filler from the front panel.
3. Slide the edge connector of the PMC module into the front panel opening from behind and place the PMC module on top of the baseboard. The four connectors on the underside of the PMC module should then connect smoothly with the corresponding connectors on the MVME7100ET.
4. Insert the four short phillips-head screws (provided with the PMC) through the holes on the bottom side of the MVME7100ET and the PMC front bezel and into rear standoffs. Tighten the screws. Refer to [Figure 2-6 on page 43](#).

5. Reinstall the MVME7100ET assembly in its proper card slot. Be sure the module is well seated in the backplane connectors. Do not damage or bend connector pins.
6. If the PMC module was installed in a non-hot swap chassis, replace the chassis or system cover(s), reconnect the system to the AC or DC power source and turn the equipment power on.

Figure 2-6 Typical Placement of a PMC Module on a VME Module

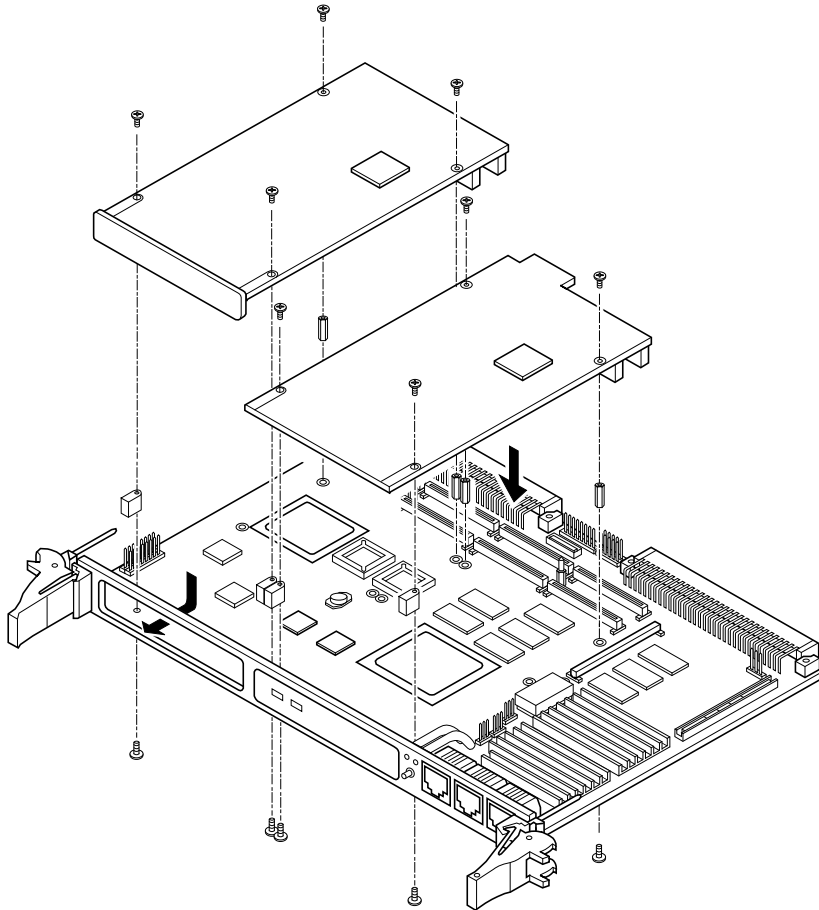

### 2.5.3 XMCspan

The XMCspan is a carrier module that provides PCI Express expansion capability to the MVME7100ET. Refer to the *XMCspan Installation and Use* manual, for details about the XMCspan and the installation procedure.

# 2.6 Installing and Removing the Board

This section describes a recommended procedure for installing a board module in a chassis. The MVME7100ET does not support hot swap, you should remove power to the slot or system before installing the module. Before installing the MVME7100ET, ensure that the serial ports and switches are properly configured.

### Installation and Removal Procedure

Before you install your module, read all cautions, warnings, and instructions described in this section.

## NOTICE

### Damage of Circuits

**Electrostatic discharge and incorrect installation and removal can damage circuits or shorten their life.**

**Before touching the board or electronic components, make sure that you are working in an ESD-safe environment.**

### Product Damage

**Only use injector handles for board insertion to avoid damage to the front panel and/or PCB. Deformation of the front panel can cause an electrical short or other board malfunction**

Use the following steps to install the MVME7100ET into your computer chassis.

1. Attach an ESD strap to your wrist. Attach the other end of the ESD strap to an electrical ground. The ESD strap must be secured to your wrist and to ground throughout the procedure.
2. Remove any filler panel that might fill that slot.
3. Install the top and bottom edge of the MVME7100ET into the guides of the chassis.
4. Ensure that the levers of the two injector/ejectors are in the outward position.
5. Slide the MVME7100ET into the chassis until resistance is felt.
6. Simultaneously move the injector/ejector levers in an inward direction.
7. Verify that the MVME7100ET is properly seated and secure it to the chassis using the two screws located adjacent to the injector/ejector levers.
8. Connect the appropriate cables to the MVME7100ET.

To remove the board from the chassis, reverse the procedure and press the red locking tabs (IEEE handles only) to extract the board.

## 2.7 Completing the Installation

The MVME7100ET is designed to operate as an application-specific computing blade or an intelligent I/O board/carrier. It can be used in any slot in a VME chassis. When the MVME7100ET is installed in a chassis, you are ready to connect peripherals and apply power to the board.

*Figure 3-1 on page 47* and *Figure 5-1 on page 81* show the locations of the various connectors on the MVME7100ET and MVME721ET.

### NOTICE

#### Product Damage

**RJ-45 connectors on modules are either twisted-pair Ethernet (TPE) or E1/T1/J1 network interfaces. Connecting an E1/T1/J1 line to an Ethernet connector may damage your system.**

- **Make sure that TPE connectors near your working area are clearly marked as network connectors.**
- **Verify that the length of an electric cable connected to a TPE bushing does not exceed 100 meters.**
- **Make sure the TPE bushing of the system is connected only to safety extra low voltage circuits (SELV circuits).**

**If in doubt, ask your system administrator.**

The console settings for the MVME7100ET are:

- Eight bits per character
- One stop bit per character
- Parity disabled (no parity)
- Baud rate of 9600 baud

Verify that hardware is installed and the power/peripheral cables connected are appropriate for your system configuration.

Replace the chassis or system cover, reconnect the chassis to the AC or DC power source, and turn the equipment power on.

## 2.8 Factory Installed Linux

A bootable ramdisk based Linux image based on the 2.6.25 kernel is available in NOR flash. To boot this image, use the following MOTLOAD commands:

```
MVME7100> bmw -af8000000 -bf8f00000 -c4000000
MVME7100> execP -14000400
```

## Hardware Preparation and Installation

---

The image should boot to the following prompt:

```
Emerson Network Power Embedded Computing Linux
Kernel 2.6.25 on a 2-processor MVME7100
localhost login:
```

Login as **root**.

The `/root/README.MVME7100_LINUX` file provides a brief overview of MVME7100ET Linux. Contact Penguin Solutions for kernel patches and additional information on using MVME7100ET Linux.

# Controls, LEDs, and Connectors

## 3.1 Overview

This chapter summarizes the controls, LEDs, connectors, and headers for the MVME7100ET baseboard. Connectors for the MVME721ET transition module can be found in [Rear Panel Connectors on page 84](#).

## 3.2 Board Layout

The following figure shows the components, LEDs, connectors, and the reset switch on the MVME7100ET.

Figure 3-1 Component Layout

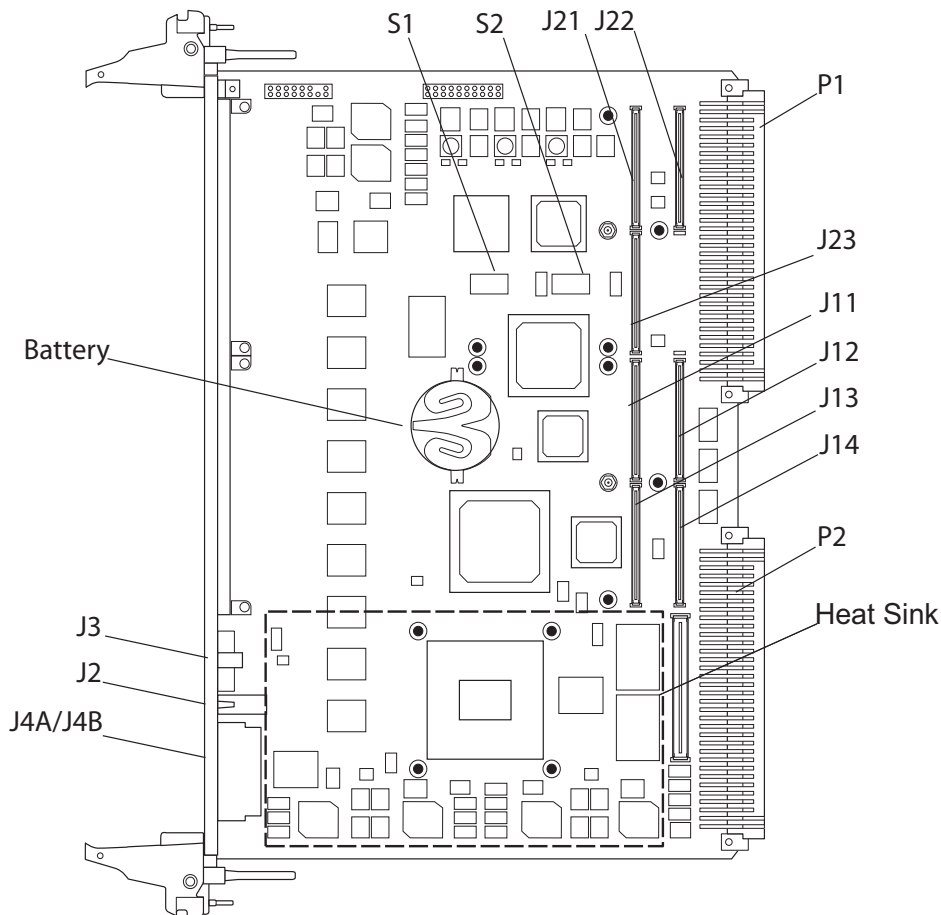

### 3.3 Front Panel

The following switch, LEDs, and connectors are available on the MVME7100ET front panel. Refer to [Figure 3-1 on page 47](#) for the location of each.

Figure 3-2 Front Panel LEDs, Connectors, Switch

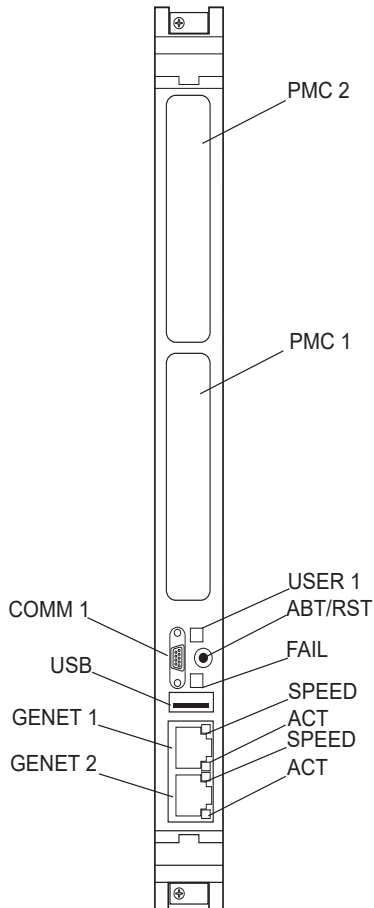

#### 3.3.1 Reset/Abort Switch

The MVME7100ET has a single push button switch to provide both the abort and reset functions. When the switch is depressed for less than 3 seconds, an abort interrupt is generated to the MC8641D PIC. If the switch is held for more than 3 seconds, a board hard reset is generated. If the MVME7100ET is the VMEbus system controller, a VME SYSRESET is generated.



### 3.3.2 LEDs

The table below describes the LEDs on the front panel of the MVME7100ET. Refer to [Figure 3-1 on page 47](#) for LED locations.

Table 3-1 Front Panel LEDs

Label	Function	Location	Color	Description
BFL	Board Fail	Front panel	Red	This indicator is illuminated during a hard reset and remains illuminated until software turns it off. The LED is controlled by bit 14 (BDFAIL) of the VSTAT register in the Tsi148.
USR1	User Defined	Front panel	Red/Yellow	This indicator is illuminated by S/W assertion of its corresponding register bits in the Status Indicator Register. See the Programmer's Guide for further detail.
GNET1 SPEED	TSEC1 Link / Speed	Front panel	Off Yellow Green	No link 10/100 BASE-T operation 1000 BASE-T operation
GNET1 ACT	TSEC1Activity	Front panel	Off Blinking Green	No activity Activity proportional to bandwidth utilization
GNET2 SPEED	TSEC2 Link / Speed	Front panel	Off Yellow Green	No link 10/100 BASE-T operation 1000 BASE-T operation
GNET2 ACT	TSEC2 Activity	Front panel	Off Blinking Green	No activity Activity proportional to bandwidth utilization

### 3.3.3 Connectors

This section describes the pin assignments and signals for the connectors on the MVME7100ET. The table below lists the standard connectors on the MVME7100ET baseboard. Refer to [Figure 3-1 on page 47](#) for connector locations. Pin assignments for the connectors are in the following sections. Some connectors use standard pin assignments in compliance with the VMEbus, IEEE, PCI, and ANSI/VITA specifications. Links to these specifications are located at [Chapter B, Related Documentation on page 113](#).

Table 3-2 Baseboard Connectors

Reference Designator	Function	Notes
J6	XMC Expansion	8X PCI-E to XMCSpan
J4A	TSEC 1, 10/100/1000 Ethernet	RJ-45
J4B	TSEC 2, 10/100/1000 Ethernet	RJ-45
J11, J12, J13, J14 J21, J22, J23	PMC1 PMC2	Implementing all recommended and optional VITA32 signals except RESETOUT#
J1	Port 0. Serial Port 1	Mini DB-9 console serial port
P1	VME five-row P1	
P2	VME five-row P2 on SBC and RTM	TSEC3 signals assigned to E1-1 thru E1-4 TSEC4 signals assigned to E2-1 thru E2-4 Serial ports 2-5
P4	Processor COP header	
P5	Boundary Scan header	

### 3.3.3.1 XMC Expansion Connector (J6)

One 76-pin Mictor connector with a center row of ground pins is used to provide XMC expansion capability. The pin assignments for this connector are as follows:

*Table 3-3 XMC Expansion Connector (J6) Pin Assignments*

Pin	Signal		Signal	Pin
1	GND	GND	GND	2
3	TX0_P		RX0_P	4
5	TX0_N		RX0_N	6
7	GND		GND	8
9	TX1_P		RX1_P	10
11	TX1_N		RX1_N	12
13	GND		GND	14
15	TX2_P		RX2_P	16
17	TX2_N		RX2_N	18
19	GND		GND	20
21	TX3_P		RX3_P	22
23	TX3_N		RX3_N	24
25	GND		GND	26
27	REFCLK_P		No Connect	28
29	REFCLK_N		No Connect	30
31	GND		GND	32
33	No Connect		No Connect	34
35	No Connect		PCIE_END_N	36
37	INT_N		RESET_N	38

## Controls, LEDs, and Connectors

Table 3-3 XMC Expansion Connector (J6) Pin Assignments (continued)

Pin	Signal		Signal	Pin
39	GND	+5V	GND	40
41	TX4_P		RX4_P	42
43	TX4_N		RX4_N	44
45	GND		GND	46
47	TX5_P		RX5_P	48
49	TX5_N		RX5_N	50
51	GND		GND	52
53	TX6_P		RX6_P	54
55	TX6_N		RX6_N	56
57	GND		GND	58
59	TX7_P		RX7_P	60
61	TX7_N		RX7_N	62
63	GND		GND	64
65	No Connect		No Connect	66
67	No Connect		No Connect	68
69	TDI		TDO	70
71	TRST_N		I2C_CLK	72
73	TMS		I2C_DATA	74
75	TCK	PRESENT_N	76	

### 3.3.3.2 Ethernet Connectors (J4A/J4B)

There are four 10/100/1000 Mb/s full duplex Ethernet interfaces using the MC8641D Triple Speed Ethernet Controllers (TSECs). Two Gigabit Ethernet interfaces are routed to the two front-panel RJ-45 connectors with integrated LEDs for speed and activity indication. The other Gigabit Ethernet interfaces are routed to P2 for rear I/O. These connectors use standard pin assignments and are as follows:

*Table 3-4 Ethernet Connectors (J4A/J4B) Pin Assignments*

Pin #	10/100/1000 Mb/s
1	_DA+
2	_DA-
3	_DB+
4	_DC+
5	_DC-
6	_DB-
7	_DD+
8	_DD-

### 3.3.3.3 PCI Mezzanine Card (PMC) Connectors (J11-J14, J21-J23)

There are seven 64-pin SMT connectors on the MVME7100ET to provide 32/64-bit PCI interfaces and P2 I/O for one optional add-on PMC.

PMC slot connector J14 contains the signals that go to VME P2 I/O rows A, C, D, and Z.

The pin assignments for these connectors are as follows:

*Table 3-5 PMC Slot 1 Connector (J11) Pin Assignments*

Pin	Signal	Signal	Pin
1	TCK	-12V	2
3	GND	INTA#	4
5	INTB#	INTC#	6
7	PMCPRSNT1#	+5V	8
9	INTD#	PCI_RSVD	10

## Controls, LEDs, and Connectors

Table 3-5 PMC Slot 1 Connector (J11) Pin Assignments (continued)

Pin	Signal	Signal	Pin
11	GND	+3.3Vaux	12
13	CLK	GND	14
15	GND	PMCGNT1#	16
17	PMCREQ1#	+5V	18
19	+3.3V (VIO)	AD31	20
21	AD28	AD27	22
23	AD25	GND	24
25	GND	C/BE3#	26
27	AD22	AD21	28
29	AD19	+5V	30
31	+3.3V (VIO)	AD17	32
33	FRAME#	GND	34
35	GND	IRDY#	36
37	DEVSEL#	+5V	38
39	GND	LOCK#	40
41	PCI_RSVD	PCI_RSVD	42
43	PAR	GND	44
45	+3.3V (VIO)	AD15	46
47	AD12	AD11	48
49	AD09	+5V	50
51	GND	C/BE0#	52
53	AD06	AD05	54
55	AD04	GND	56
57	+3.3V (VIO)	AD03	58

Table 3-5 *PMC Slot 1 Connector (J11) Pin Assignments (continued)*

Pin	Signal	Signal	Pin
59	AD02	AD01	60
61	AD00	+5V	62
63	GND	REQ64#	64

Table 3-6 *PMC Slot 1 Connector (J12) Pin Assignments*

Pin	Signal	Signal	Pin
1	+12V	TRST#	2
3	TMS	TDO	4
5	TDI	GND	6
7	GND	Not Used	8
9	Not Used	Not Used	10
11	Pull-up	+3.3V	12
13	RST#	Pull-down	14
15	+3.3V	Pull-down	16
17	Not Used	GND	18
19	AD30	AD29	20
21	GND	AD26	22
23	AD24	+3.3V	24
25	IDSEL1	AD23	26
27	+3.3V	AD20	28
29	AD18	GND	30
31	AD16	C/BE2#	32
33	GND	IDSEL1B	34
35	TRDY#	+3.3V	36

## Controls, LEDs, and Connectors

Table 3-6 PMC Slot 1 Connector (J12) Pin Assignments (continued)

Pin	Signal	Signal	Pin
37	GND	STOP#	38
39	PERR#	GND	40
41	+3.3V	SERR#	42
43	C/BE1#	GND	44
45	AD14	AD13	46
47	M66EN	AD10	48
49	AD08	+3.3V	50
51	AD07	REQ1B#	52
53	+3.3V	GNT1B#	54
55	Not Used	GND	56
57	Not Used	EREDY0	58
59	GND	Not Used	60
61	ACK64#	+3.3V	62
63	GND	No Connect (MONARCH#)	64

Table 3-7 PMC Slot 1 Connector (J13) Pin Assignments

Pin	Signal	Signal	Pin
1	Reserved	GND	2
3	GND	C/BE7#	4
5	C/BE6#	C/BE5#	6
7	C/BE4#	GND	8
9	+3.3V (VIO)	PAR64	10
11	AD63	AD62	12
13	AD61	GND	14



Table 3-7 PMC Slot 1 Connector (J13) Pin Assignments (continued)

Pin	Signal	Signal	Pin
15	GND	AD60	16
17	AD59	AD58	18
19	AD57	GND	20
21	+3.3V (VIO)	AD56	22
23	AD55	AD54	24
25	AD53	GND	26
27	GND	AD52	28
29	AD51	AD50	30
31	AD49	GND	32
33	GND	AD48	34
35	AD47	AD46	36
37	AD45	GND	38
39	+3.3V (VIO)	AD44	40
41	AD43	AD42	42
43	AD41	GND	44
45	GND	AD40	46
47	AD39	AD38	48
49	AD37	GND	50
51	GND	AD36	52
53	AD35	AD34	54
55	AD33	GND	56
57	+3.3V (VIO)	AD32	58
59	Reserved	Reserved	60

## Controls, LEDs, and Connectors

Table 3-7 PMC Slot 1 Connector (J13) Pin Assignments (continued)

Pin	Signal	Signal	Pin
61	Reserved	GND	62
63	GND	Reserved	64

Table 3-8 PMC Slot 1 Connector (J14) Pin Assignments

Pin	Signal	Signal	Pin
1	PMC1_1 (P2-C1)	PMC1_2 (P2-A1)	2
3	PMC1_3 (P2-C2)	PMC1_4 (P2-A2)	4
5	PMC1_5 (P2-C3)	PMC1_6 (P2-A3)	6
7	PMC1_7 (P2-C4)	PMC1_8 (P2-A4)	8
9	PMC1_9 (P2-C5)	PMC1_10 (P2-A5)	10
11	PMC1_11 (P2-C6)	PMC1_12 (P2-A6)	12
13	PMC1_13 (P2-C7)	PMC1_14 (P2-A7)	14
15	PMC1_15 (P2-C8)	PMC1_16 (P2-A8)	16
17	PMC1_17 (P2-C9)	PMC1_18 (P2-A9)	18
19	PMC1_19 (P2-C10)	PMC1_20 (P2-A10)	20
21	PMC1PMC1_21 (P2-C11)	PMC1_22 (P2-A11)	22
23	PMC1_23 (P2-C12)	PMC1_24 (P2-A12)	24
25	PMC1_25 (P2-C13)	PMC1_26 (P2-A13)	26
27	PMC1_27 (P2-C14)	PMC1_28 (P2-A14)	28
29	PMC1_29 (P2-C15)	PMC1_30 (P2-A15)	30
31	PMC1_31 (P2-C16)	PMC1_32 (P2-A16)	32
33	PMC1_33 (P2-C17)	PMC1_34 (P2-A17)	34
35	PMC1_35 (P2-C18)	PMC1_36 (P2-A18)	36
37	PMC1_37 (P2-C19)	PMC1_38 (P2-A19)	38

## Controls, LEDs, and Connectors

Table 3-8 PMC Slot 1 Connector (J14) Pin Assignments (continued)

Pin	Signal	Signal	Pin
39	PMC1_39 (P2-C20)	PMC1_40 (P2-A20)	40
41	PMC1_41 (P2-C21)	PMC1_42 (P2-A21)	42
43	PMC1_43 (P2-C22)	PMC1_44 (P2-A22)	44
45	PMC1_45 (P2-C23)	PMC1_46 (P2-A23)	46
47	PMC1_47 (P2-C24)	PMC1_48 (P2-A24)	48
49	PMC1_49 (P2-C25)	PMC1_50 (P2-A25)	50
51	PMC1_51 (P2-C26)	PMC1_52 (P2-A26)	52
53	PMC1_53 (P2-C27)	PMC1_54 (P2-A27)	54
55	PMC1_55 (P2-C28)	PMC1_56 (P2-A28)	56
57	PMC1_57 (P2-C29)	PMC1_58 (P2-A29)	58
59	PMC1_59 (P2-C30)	PMC1_60 (P2-A30)	60
61	PMC1_61 (P2-C31)	PMC1_62 (P2-A31)	62
63	PMC1_63 (P2-C32)	PMC1_64 (P2-A32)	64

Table 3-9 PMC Slot 2 Connector (J21) Pin Assignments

Pin	Signal	Signal	Pin
1	TCK	-12V	2
3	GND	INTC#	4
5	INTD#	INTA#	6
7	PMCPRSNT1#	+5V	8
9	INTB#	PCI_RSVD	10
11	GND	+3.3Vaux	12
13	CLK	GND	14
15	GND	PMCGNT1#	16

## Controls, LEDs, and Connectors

Table 3-9 PMC Slot 2 Connector (J21) Pin Assignments (continued)

Pin	Signal	Signal	Pin
17	PMCREQ1#	+5V	18
19	+3.3V (VIO)	AD31	20
21	AD28	AD27	22
23	AD25	GND	24
25	GND	C/BE3#	26
27	AD22	AD21	28
29	AD19	+5V	30
31	+3.3V (VIO)	AD17	32
33	FRAME#	GND	34
35	GND	IRDY#	36
37	DEVSEL#	+5V	38
39	GND	LOCK#	40
41	PCI_RSVD	PCI_RSVD	42
43	PAR	GND	44
45	+3.3V (VIO)	AD15	46
47	AD12	AD11	48
49	AD09	+5V	50
51	GND	C/BE0#	52
53	AD06	AD05	54
55	AD04	GND	56
57	+3.3V (VIO)	AD03	58
59	AD02	AD01	60
61	AD00	+5V	62
63	GND	REQ64#	64

Table 3-10 PMC Slot 2 Connector (J22) Pin Assignments

Pin	Signal	Signal	Pin
1	+12V	TRST#	2
3	TMS	TDO	4
5	TDI	GND	6
7	GND	Not Used	8
9	Not Used	Not Used	10
11	Pull-up	+3.3V	12
13	RST#	Pull-down	14
15	+3.3V	Pull-down	16
17	Not Used	GND	18
19	AD30	AD29	20
21	GND	AD26	22
23	AD24	+3.3V	24
25	IDSEL1	AD23	26
27	+3.3V	AD20	28
29	AD18	GND	30
31	AD16	C/BE2#	32
33	GND	IDSEL1B	34
35	TRDY#	+3.3V	36
37	GND	STOP#	38
39	PERR#	GND	40
41	+3.3V	SERR#	42
43	C/BE1#	GND	44
45	AD14	AD13	46

## Controls, LEDs, and Connectors

Table 3-10 PMC Slot 2 Connector (J22) Pin Assignments (continued)

Pin	Signal	Signal	Pin
47	M66EN	AD10	48
49	AD08	+3.3V	50
51	AD07	REQ1B#	52
53	+3.3V	GNT1B#	54
55	Not Used	GND	56
57	Not Used	EREDY1	58
59	GND	Not Used	60
61	ACK64#	+3.3V	62
63	GND	No Connect (MONARCH#)	64

Table 3-11 PMC Slot 2 Connector (J23) Pin Assignments

Pin	Signal	Signal	Pin
1	Reserved	GND	2
3	GND	C/BE7#	4
5	C/BE6#	C/BE5#	6
7	C/BE4#	GND	8
9	+3.3V (VIO)	PAR64	10
11	AD63	AD62	12
13	AD61	GND	14
15	GND	AD60	16
17	AD59	AD58	18
19	AD57	GND	20
21	+3.3V (VIO)	AD56	22
23	AD55	AD54	24

Table 3-11 *PMC Slot 2 Connector (J23) Pin Assignments (continued)*

Pin	Signal	Signal	Pin
25	AD53	GND	26
27	GND	AD52	28
29	AD51	AD50	30
31	AD49	GND	32
33	GND	AD48	34
35	AD47	AD46	36
37	AD45	GND	38
39	+3.3V (VIO)	AD44	40
41	AD43	AD42	42
43	AD41	GND	44
45	GND	AD40	46
47	AD39	AD38	48
49	AD37	GND	50
51	GND	AD36	52
53	AD35	AD34	54
55	AD33	GND	56
57	+3.3V (VIO)	AD32	58
59	Reserved	Reserved	60
61	Reserved	GND	62
63	GND	Reserved	64

## Controls, LEDs, and Connectors

### 3.3.3.4 Serial Port Connector (COM1/J1)

There is one front access asynchronous serial port interface (SP0) that is routed to the mini DB-9 front-panel connector. The pin assignments for these connectors are as follows:

Table 3-12 COM1 Port Connector Pin Assignments

Pin	Signal
1	No connect
2	RX
3	TX
4	No Connect
5	GND
6	No Connect
7	RTS
8	CTS
9	No Connect

### 3.3.3.5 VMEbus P1 Connector

The VME P1 connector is a 160-pin DIN. The P1 connector provides power and VME signals for 24-bit address and 16-bit data. The pin assignments for the P1 connector is as follows:

Table 3-13 VMEbus P1 Connector Pin Assignments

	ROW Z	ROW A	ROW B	ROW C	ROW D	
1	Reserved	D00	BBSY*	D08	+5V	1
2	GND	D01	BCLR*	D09	GND	2
3	Reserved	D02	ACFAIL*	D10	Reserved	3
4	GND	D03	BG0IN*	D11	Reserved	4
5	Reserved	D04	BG0OUT*	D12	Reserved	5
6	GND	D05	BG1IN*	D13	Reserved	6
7	Reserved	D06	BG1OUT*	D14	Reserved	7



## Controls, LEDs, and Connectors

Table 3-13 VMEbus P1 Connector Pin Assignments (continued)

	ROW Z	ROW A	ROW B	ROW C	ROW D	
8	GND	D07	BG2IN*	D15	Reserved	8
9	Reserved	GND	BG2OUT*	GND	GAP_L	9
10	GND	SYSCLK	BG3IN*	SYSFAIL*	GA0_L	10
11	Reserved	GND	BG3OUT*	BERR*	GA1_L	11
12	GND	DS1*	BR0*	SYSRESET*	Reserved	12
13	Reserved	DS0*	BR1*	LWORD*	GA2_L	13
14	GND	WRITE*	BR2*	AM5	Reserved	14
15	Reserved	GND	BR3*	A23	GA3_L	15
16	GND	DTACK*	AM0	A22	Reserved	16
17	Reserved	GND	AM1	A21	GA4_L	17
18	GND	AS*	AM2	A20	Reserved	18
19	Reserved	GND	AM3	A19	Reserved	19
20	GND	IACK*	GND	A18	Reserved	20
21	Reserved	IACKIN*	SERA	A17	Reserved	21
22	GND	IACKOUT*	SERB	A16	Reserved	22
23	Reserved	AM4	GND	A15	Reserved	23
24	GND	A07	IRQ7*	A14	Reserved	24
25	Reserved	A06	IRQ6*	A13	Reserved	25
26	GND	A05	IRQ5*	A12	Reserved	26
27	Reserved	A04	IRQ4*	A11	Reserved	27
28	GND	A03	IRQ3*	A10	Reserved	28
29	Reserved	A02	IRQ2*	A09	Reserved	29
30	GND	A01	IRQ1*	A08	Reserved	30

## Controls, LEDs, and Connectors

Table 3-13 VMEbus P1 Connector Pin Assignments (continued)

	ROW Z	ROW A	ROW B	ROW C	ROW D	
31	Reserved	-12V	+5VSTDBY	+12V	GND	31
32	GND	+5V	+5V	+5V	+5V	32

### 3.3.3.6 VMEbus P2 Connector

The VME P2 connector is a 160-pin DIN. Row B of the P2 connector provides power to the MVME7100ET and to the upper eight VMEbus address lines and additional 16 VMEbus data lines. The Z, A, C, and D pin assignments for the P2 connector are the same for both the MVME7100ET and MVME721ET, and are as follows:

Table 3-14 VME P2 Connector Pinouts

Pin	P2-Z	P2-A	P2-B	P2-C	P2-D
1	SP1RX	PMC1_IO2	+5V	PMC1_IO1	E1-1+
2	GND	PMC1_IO4	GND	PMC1_IO3	E1-1-
3	SP1TX	PMC1_IO6	VRETRY_L	PMC1_IO5	GND
4	GND	PMC1_IO8	VA24	PMC1_IO7	E1-2+
5	SP1CTS	PMC1_IO10	VA25	PMC1_IO9	E1-2-
6	GND	PMC1_IO12	VA26	PMC1_IO11	GND
7	SP1RTS	PMC1_IO14	VA27	PMC1_IO13	E1-3+
8	GND	PMC1_IO16	VA28	PMC1_IO15	E1-3-
9	SP2RX	PMC1_IO18	VA29	PMC1_IO17	GND
10	GND	PMC1_IO20	VA30	PMC1_IO19	E1-4+
11	SP2TX	PMC1_IO22	VA31	PMC1_IO21	E1-4-
12	GND	PMC1_IO24	GND	PMC1_IO23	GND
13	SP2CTS	PMC1_IO26	+5V	PMC1_IO25	I2C_SDA
14	GND	PMC1_IO28	VD16	PMC1_IO27	I2C_SCL
15	SP2RTS	PMC1_IO30	VD17	PMC1_IO29	E1_LINK
16	GND	PMC1_IO32	VD18	PMC1_IO31	E1_ACT

Table 3-14 VME P2 Connector Pinouts (continued)

Pin	P2-Z	P2-A	P2-B	P2-C	P2-D
17	SP3RX	PMC1_IO34	VD19	PMC1_IO33	E2_LINK
18	GND	PMC1_IO36	VD20	PMC1_IO35	E2_ACT
19	SP3TX	PMC1_IO38	VD21	PMC1_IO37	GND
20	GND	PMC1_IO40	VD22	PMC1_IO39	E2-4-
21	SP3CTS	PMC1_IO42	VD23	PMC1_IO41	E2-4+
22	GND	PMC1_IO44	GND	PMC1_IO43	GND
23	SP3RTS	PMC1_IO46	VD24	PMC1_IO45	E2-3-
24	GND	PMC1_IO48	VD25	PMC1_IO47	E2-3+
25	SP4RX	PMC1_IO50	VD26	PMC1_IO49	GND
26	GND	PMC1_IO52	VD27	PMC1_IO51	E2-2-
27	SP4TX	PMC1_IO54	VD28	PMC1_IO53	E2-2+
28	GND	PMC1_IO56	VD29	PMC1_IO55	GND
29	SP4CTS	PMC1_IO58	VD30	PMC1_IO57	E2-1-
30	GND	PMC1_IO60	VD31	PMC1_IO59	E2-1+
31	SP4RTS	PMC1_IO62	GND	PMC1_IO61	GND
32	GND	PMC1_IO64	+5V	PMC1_IO63	+5V

### 3.3.3.7 MVME721ET PMC I/O Module (PIM) Connectors (J10, J14)

PMC Host I/O connector J10 routes only power and ground from VME P2. There are no Host I/O signals on this connector. The MVME7100ET routes PMC I/O from J14 of PMC Slot 1 to VME P2 rows A and C. The MVME721ET routes these signals (pin-for-pin) from VME P2 to PMC I/O Module connector J14. See [Table 3-15](#) and [Table 3-8](#) for the pin assignments.

Table 3-15 MVME721ET Host I/O Connector (J10) Pin Assignments

Pin	Signal	Signal	Pin
1	No Connect	No Connect	2

## Controls, LEDs, and Connectors

Table 3-15 MVME721ET Host I/O Connector (J10) Pin Assignments (continued)

Pin	Signal	Signal	Pin
3	No Connect	No Connect	4
5	+5V	No Connect	6
7	No Connect	No Connect	8
9	No Connect	+3.3V	10
11	No Connect	No Connect	12
13	GND	No Connect	14
15	No Connect	No Connect	16
17	No Connect	GND	18
19	No Connect	No Connect	20
21	+5V	No Connect	22
23	No Connect	No Connect	24
25	No Connect	+3.3V	26
27	No Connect	No Connect	28
29	GND	No Connect	30
31	No Connect	No Connect	32
33	No Connect	GND	34
35	No Connect	No Connect	36
37	+5V	No Connect	38
39	No Connect	No Connect	40
41	No Connect	+3.3V	42
43	No Connect	No Connect	44
45	GND	No Connect	46
47	No Connect	No Connect	48
49	No Connect	GND	50

*Table 3-15 MVME721ET Host I/O Connector (J10) Pin Assignments (continued)*

Pin	Signal	Signal	Pin
51	No Connect	No Connect	52
53	+5V	No Connect	54
55	No Connect	No Connect	56
57	No Connect	+3.3V	58
59	No Connect	No Connect	60
61	No Connect	No Connect	62
63	No Connect	No Connect	64

## 3.4 Headers

This section describes the pin assignments of the Headers on the MVME7100ET.

### 3.4.1 Processor COP Header (P4)

There is one standard 16-pin header that provides access to the COP function. The pin assignments for this header are as follows:

*Table 3-16 Processor COP Header (P4) Pin Assignments*

Pin	Signal	Signal	Pin
1	CPU_TDO	No Connect	2
3	CPU_TDI	CPU_TRST_L	4
5	Pullup	CPU_VIO (+3.3V)	6
7	CPU_TCK	CPU_CKSTPI_L	8
9	CPU_TMS	No Connect	10
11	CPU_SRST_L	GND	12
13	CPU_HRST_L	KEY (no pin)	14
15	CPU_CKSTPO_L	GND	16

## Controls, LEDs, and Connectors

---

**NOTE:** Pin 6 +3.3V has a 100W resistor to +3.3V.

### 3.4.2 Boundary Scan Header (P5)

The 20-pin boundary scan header provides an interface for programming the on-board PLDs and for boundary scan testing/debug purposes. The pin assignments for this header are as follows:

*Table 3-17 Boundary Scan Header (P5) Pin Assignments*

Pin	Signal	Signal	Pin
1	TCK	GND	2
3	TDO	GND	4
5	TMS	GND	6
7	TRST_N	GND	8
9	TDI	(BSCANEN_N)	10
11	KEY	No Connect	12
13	GND	AUTOWR_N	14
15	GND	No Connect	16
17	GND	No Connect	18
19	GND	No Connect	20

**NOTE:** Pin 10 must be grounded in the cable in order to enable boundary scan.

# Functional Description

---

## 4.1 Overview

The MVME7100ET VMEbus board is based on the MC8640D (1.067GHz versions) and the MC8641D (1.33GHz versions) Integrated Processors. The MVME7100ET provides front panel access to one serial port with a mini DB-9 connector and two 10/100/1000 Ethernet ports with two RJ-45 connectors. The front panel includes a fail indicator LED, user-defined indicator LED, and a reset/abort switch.

The MVME721ET transition module provides rear panel access to four serial ports with one RJ-45 connector per port and two 10/100/1000 Ethernet ports with two RJ-45 connectors. The transition module also provides two planar connectors for one PIM with front I/O.

The block diagram for the MVME7100ET Single Board Computer is shown in [Table 4-1](#) and the block diagram for the MVME721ET transition module is shown in [Figure 5-2](#).

## 4.2 Block Diagram

The following figure is a block diagram of the MVME7100ET architecture.

Figure 4-1 Block Diagram

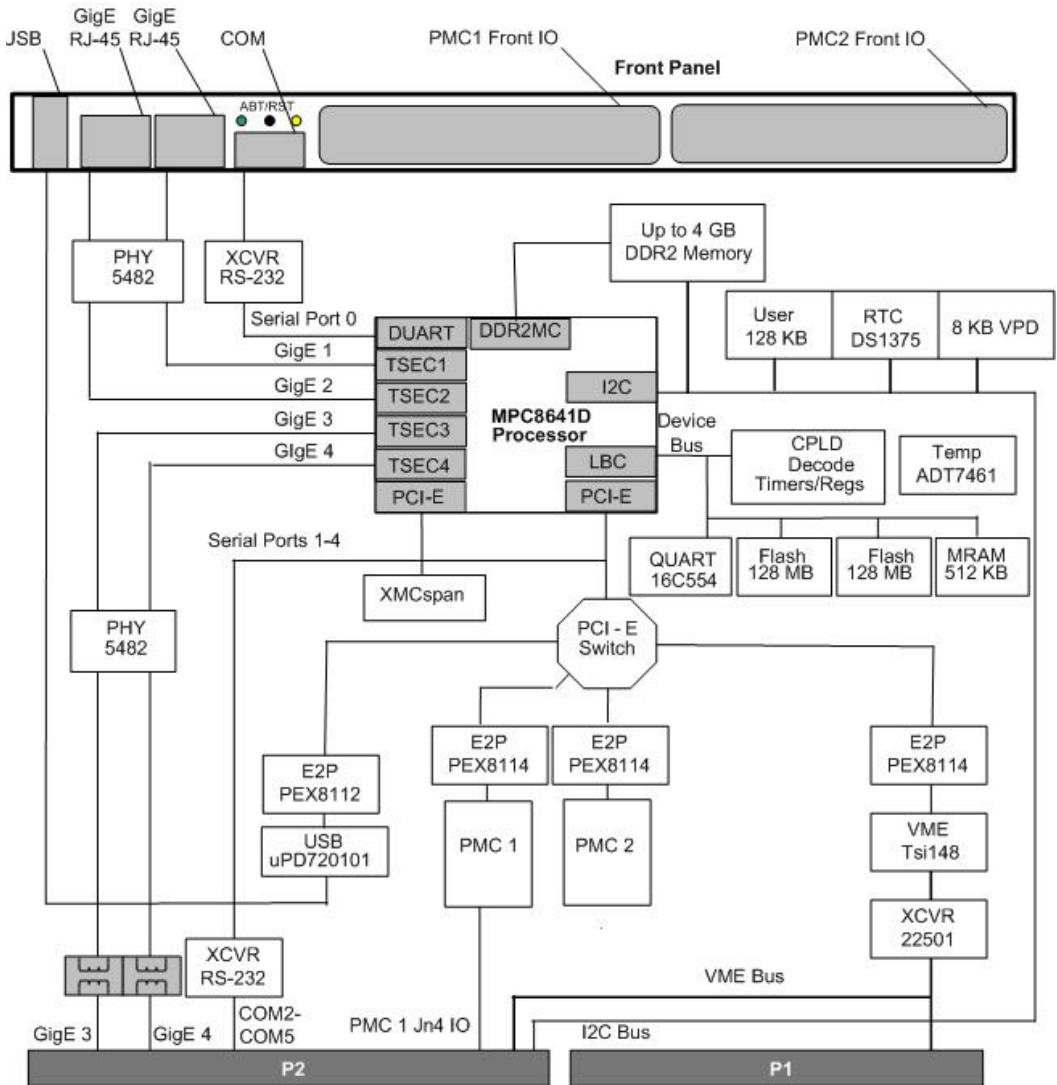



## 4.3 Processor

The MVME7100ET is designed to support the MC864xD (dual e600 core) processor. The processor is configured to operate at 1.067GHz or 1.33GHz core frequency with a corresponding DDR400 Mb or DDR533 DDR2 memory bus.

The MVME7100ET supports the power-on reset (POR) pin sampling method for processor reset configuration. The states of the various configuration pins on the processor are sampled when reset is de-asserted to determine the desired operating modes. Combinations of pull-up and pull-down resistors are used to set the options. Some options are fixed and some are selectable at build time by installing the proper pull-up/pull-down resistor. Refer to the MC864xD reference manual, listed in [Appendix B, Related Documentation on page 113](#), and [Manufacturers' Documents on page 113](#) for additional details and/or programming information.

## 4.4 I<sup>2</sup>C Serial Interface and Devices

The MVME7100ET provides the following on-board I<sup>2</sup>C serial devices connected to the MC864xD I<sup>2</sup>C controller 0 interface:

- 8 KB serial EEPROM for VPD
- Two 64 KB serial EEPROMs for user configuration data storage
- Two 256 byte serial EEPROMs for SPD
- Maxim DS1375 Real Time Clock
- On-Semi ADT7146 temperature sensor
- 8 KB serial EEPROM on RTM VPD

The RTC implemented on the MVME7100ET provides an alarm interrupt routed to the MC864xD PIC through the control PLD. A DS32KHz temperature controlled crystal oscillator provides the RTC clock reference. A battery backup circuit for the RTC is provided on-board.

The On-Semi digital temperature sensor measures of temperature of the board and also connects to the temperature diode on the MC864xD. The temperature sensor also provides an alarm interrupt routed to the MC864xD PIC through the control PLD.

The I<sup>2</sup>C interface is routed to the P2 connector for access to the serial EEPROM located on the transition module. The device address for the transition module serial EEPROM is user selectable using the configuration switches. Refer to [Chapter 5, Transition Module](#) for information on the switches.

For programming information, see the *MVME7100ET Single Board Computer Programmer's Reference*.

### 4.5 System Memory

The MC864xD includes two memory controllers. The MVME7100ET supports one bank of memory on each controller. The MVME7100ET supports 1 GB and 2 GB DDR2 SDRAMs. This provides memory configurations of 2 GB or 4 GB. The MVME7100ET supports memory speeds up to DDR533.

### 4.6 Timers

Timing functions for the MVME7100ET are provided by four global high-resolution timers integrated into the MC864xD plus four additional independent 32-bit timers.

The four integrated 32-bit timers are clocked by the RTC input which is driven by a 1 MHz clock. Refer to the MC864xD reference manual, listed in [Appendix B, Related Documentation on page 113](#), and [Manufacturers' Documents on page 113](#) for additional details and/or programming information

The clock source for the four 32-bit timers in the PLD is 25MHz. The timer prescaler must be configured to generate a 1MHz timer reference. For programming information, see *MVME7100ET Single Board Computer Programmer's Reference*.

### 4.7 Ethernet Interfaces

The MVME7100ET provides four 10/100/1000 Mbps full-duplex Ethernet interfaces using the MC864xD Ethernet Controllers. Two Broadcom BCM5482S PHYs are used. The Ethernet ports on the MC864xD are configured to operate in RGMII mode. Two Gigabit Ethernet interfaces are routed to front panel RJ-45 connectors with integrated LEDs for speed and activity indication. The other two Gigabit Ethernet interfaces are routed to P2 for rear I/O. For programming information, see *MVME7100ET Single Board Computer Programmer's Reference*.

### 4.8 Local Bus Interface

The MVME7100ET uses the MC864xD Local Bus Controller (LBC) for access to on-board flash and I/O registers. The LBC has programmable timing modes to support devices of different access times, as well as device widths of 8, 16, and 32 bits. The MVME7100ET uses the LBC in GPCM mode to interface to two physical banks of on-board flash, an on-board Quad UART (QUART), an MRAM, and on-board 32-bit timers along with control/status registers. Access timing for each device type is programmable and depends on the device timing data found in the VPD during initialization.

A hardware flash bank write protect switch is provided on the MVME7100ET to enable write protection of the NOR Flash. Regardless of the state of the software flash write protect bit in the NOR Flash Control/Status register, write protection is enabled when this switch is ON. When this switch is OFF, write protection is controlled by the state of the software flash write protect bits and can only be disabled by clearing this bit in the NOR Flash Control/Status register. Note that the F\_WE\_HW bit reflects the state of the switch and is only software readable whereas the F\_WP\_SW bit supports both read and write operations.

The MVME7100ET provides a dual boot option for booting from one of two separate boot images in the boot flash bank which are referred to as boot block A and boot block B. Boot blocks A and B are each 1 MB in size and are located at the top (highest address) 2 MB of the boot flash memory space. Block A is located at the highest 1 MB block and block B is the next highest 1 MB block. A flash boot block switch is used to select between boot block A and boot block B. When the switch is OFF, the flash memory map is normal and block A is selected as shown in Figure 3. When the switch is ON, block B is mapped to the highest address as shown in Figure 4. The MAP\_SELECT bit in the flash Control/Status register can disable the jumper and restore the memory map to the normal configuration with block A selected.

### 4.8.1 Flash Memory

The MVME7100ET is designed to provide 128 MB of soldered-on NOR flash memory. Two AMD +3.3 V devices are configured to operate in 16-bit mode to form a 32-bit flash bank. This flash bank is also the boot bank and is connected to LBC Chip Select 0 and 1.

Also included is a second bank of NAND flash, up to 8 GB, connected to LBC Chip Select 2. The VPD flash packet(s) will determine which devices are populated and the size of the devices. Programming details can be found in the *MVME7100ET Single Board Computer Programmer's Reference* manual.

### 4.8.2 NVRAM

The MVME7100ET includes one NXP 512MB MRAM device connected to the MC864xD device control bus to provide a non-volatile memory that has unlimited writes, fast access and long term data retention without power. The MRAM is organized as 256K by 16. Refer to the data sheet for additional information

### 4.8.3 Quad UART (QUART)

The MVME7100ET contains one Quad UART device connected to the MC864xD device control bus to provide additional asynchronous serial ports. The Quad UART provides four asynchronous serial ports which are routed to the P2 connector. The TTL-level signals of RX, TX, CTS, and RTS from each port are routed through on-board RS-232 drivers and

## Functional Description

---

receivers to the P2 connector where the signals can be picked up by a transition module. The reference clock frequency for the QUART is 1.8432MHz. All UART ports are capable of signaling at up to 115 Kbaud. Refer to the ST16C554D data sheet for additional details and/or programming information.

### 4.8.4 Control and Timers PLD

The MVME7100ET Control and Timers PLD resides on the local bus. The Control and Timers PLD provides the following functions on the board:

- Local bus address latch
- Chip selects for flash banks, MRAM, and Quad UART
- System control and status registers
- Four 32-bit tick timers
- Watch Dog Timer
- RTC 1 MHz reference clock

## 4.9 DUART Interface

The MVME7100ET provides a front access asynchronous serial port interface using Serial Port 0 from the MC864xD DUART. The TTL-level signals SIN, SOUT, RTS and CTS from Serial Port 0 are routed through on-board RS-232 drivers and receivers to the mini DB-9 front panel connector.

## 4.10 PCI-E Port 0

One 8x PCI-E port from the MC864xD processor is connected to a five port PEX8533 PCI-E switch. Each downstream port from the PCI-E switch is connected to a PCI/PCI-X bridge. The MVME7100ET implements four separate PCI/PCI-X bus segments.

PCI-X bus 1 connects to PMC site 1 using a PEX8114 bridge and is configured dynamically, with on-board logic, to operate in 33/66MHz PCI or 66/100MHz PCI-X mode depending on the PMC installed.

PCI-X bus 2 connects to PMC site 2 using a PEX8114 bridge and is configured dynamically, with on-board logic, to operate in 33/66MHz PCI or 66/100MHz PCI-X mode depending on the PMC installed.

PCI-X bus 3 connects to the Tsi148 using a PEX8114 bridge and is configured for 133MHz PCI-X mode.

### 4.10.1 VME Controller

The VMEbus interface for the MVME7100ET is provided by the Tsi148 VMEbus controller. The Tsi148 provides the required VME, VME extensions, and 2eSST functions. TI SN74VMEH22501 transceivers are used to buffer the VME signals between the Tsi148 and the VME backplane. Refer to the Tsi148 user's manual for additional details and/or programming information.

### 4.11 XMC Expansion

The MVME7100ET provides an additional XMC/PMC module capability through the use of a 78-pin stacking connector. This connector is connected to the second PCI Express port on the processor. Up to four additional XMC/PMC modules may be added by using two expansion boards. Refer to the XMCspan data sheet for additional details and/or programming information.

### 4.12 Power Supplies

The MVME7100ET on-board voltages will be generated using Linear Tech LTC3828 dual output two phase controllers and LTC3416 single output controllers. The following sections detail the MVME7100ET power requirements.

#### 4.12.1 Power Sequencing

In order to meet the power sequencing requirements of the various components on the MVME7100ET, the power supply controllers implement voltage tracking which allows the power supply outputs to track each other coincidentally during power up and power down. The +3.3V supply output will be used as the tracking reference. All supply outputs will reach their final values within 20 milliseconds during power up.

#### 4.12.2 Power Supply Monitor

Logic is provided on-board to monitor the PGOOD signal from the LTC3828 and LTC3416 regulators to determine if the power supply outputs are within tolerance. If any of the power supplies fail, this logic shuts off the power supplies to avoid any component damage. If the +5.0V power supply is still good during a fail condition, a planar red LED (PWR FAIL D9) is illuminated to indicate the power supply fail condition.

## Functional Description

---

### 4.12.3 Power Supply Filtering and Fusing

Each of the switching power supply inputs on the MVME7100ET will have an inductor to reduce switching noise from being fed back onto the +5.0V input. The LTC3828 supplies will each have a 10A fuse to protect the supplies from over-current in case of component failure.

## 4.13 Clock Distribution

The clock function generates and distributes all of the clocks required for system operation. The PCI-E clocks are generated using an eight output differential clock driver. The PCI/PCI-X bus clocks are generated by the bridge chips from the PCI-E clock. Additional clocks required by individual devices are generated near the devices using individual oscillators. For clock assignments, refer to the *MVME7100ET Single Board Computer Programmer's Reference* manual.

### 4.13.1 System Clock

The system clock is driven by an oscillator. The following table defines the clock frequencies for various configurations.

Table 4-1 Clock Frequencies

SYSCLK	Core	MPX (Platform)	DDR2
66.67MHz	1.3GHz	533MHz	266MHz
66.67MHz	1.067GHz	533MHz	266MHz

### 4.13.2 Real Time Clock Input

The RTC clock input is driven by a 1MHz clock generated by the Control and Timers PLD. This provides a fixed clock reference for the MC864xD PIC timers which software can use as a known timing reference.

### 4.13.3 Local Bus Controller Clock Divisor

The Local Bus Controller (LBC) clock output is connected to the PLD but is not used by the internal logic

### 4.14 Reset Control Logic

There are multiple sources of reset on the MVME7100ET. The following sources generate a board level reset:

- Power-up
- Reset switch
- Watchdog timer
- System control register (BRD\_RST)
- VMEbus reset

A board level hard reset generates a reset for the entire SBC including the processor, local PCI/PCI-X buses, Ethernet PHYs, serial ports, flash devices, and PLD(s). If the MVME7100ET is configured as the VME system controller, the VMEbus and local Tsi148 reset input are also reset.

### 4.15 Real Time Clock Battery

There is an on-board battery holder that provides easy replacement of a +3.0V button cell lithium battery which provides back-up power to the on-board Real-Time Clock. A battery switching circuit provides automatic switching between the +3.3V and battery voltages.

## Functional Description

---



# Transition Module

## 5.1 Overview

This chapter provides information on the MVME721ET transition module's features. It also includes a drawing of the module showing the components and rear panel connectors.

## 5.2 Transition Module Layout

The following illustration shows the component layout and connectors on the MVME721ET transition module.

Figure 5-1 Component Layout

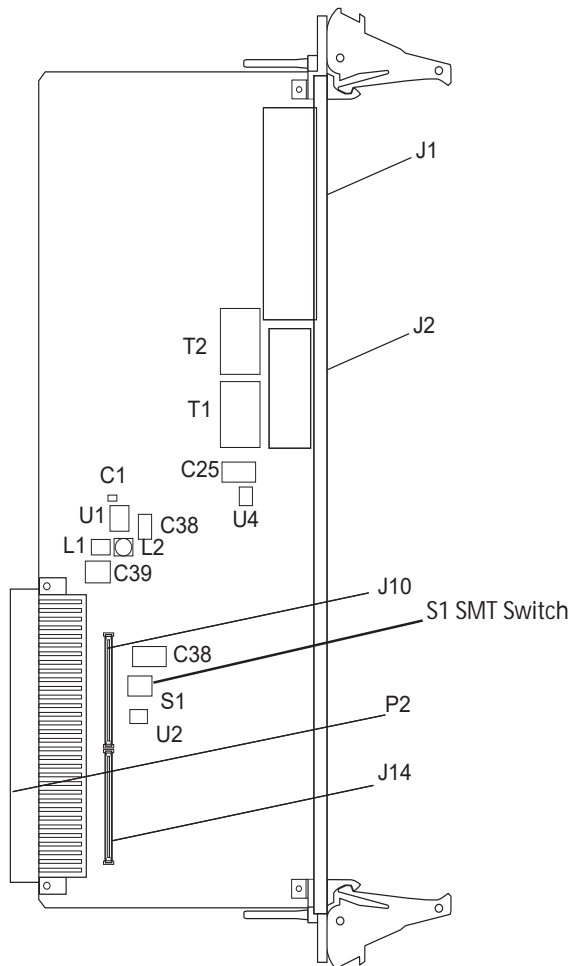

### 5.3 Features

The MVME721ET transition module is for I/O routing through the rear of a compact VMEbus chassis. It connects directly to the VME backplane in chassis' with an 80mm deep rear transition area. The MVME721ET is designed for use with the host MVME7100ET board. It has these features:

Table 5-1 Transition Module Features

Function	Features
I/O	One five-row P2 backplane connector for serial and Ethernet I/O passed from the SBC Four RJ-45 connectors for rear panel I/O: four asynchronous serial channels Two RJ-45 connectors with integrated LEDs for rear panel I/O: two 10/100/1000 Ethernet channels One PIM site with rear panel I/O

Figure 5-2 Block Diagram

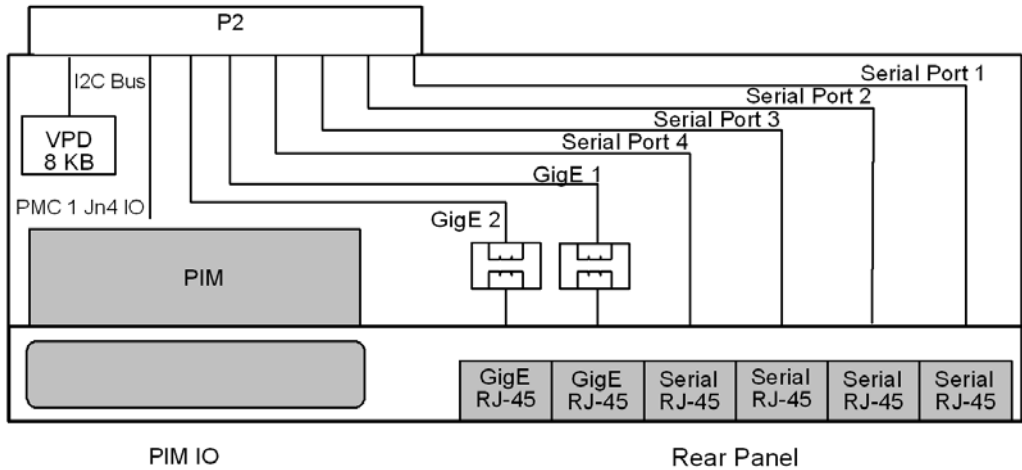

## 5.4 SEEPROM Address Switch, S1

A 4-position SMT configuration switch is located on the MVME721ET transition module to set the device address of the RTM serial EEPROM device. The switch settings are defined in the next table. To see switch location, refer to [Figure 5-1 on page 81](#).

Figure 5-3 S1 Switch Positions

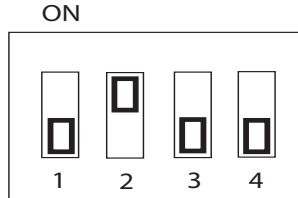

Table 5-2 SEEPROM Address Switch Assignments (RTM)

Position	SW4	SW3	SW2	SW1
Function	WP	A(2)	A(1)	A(0)
Default (OFF)	0	1	1	1

Table 5-3 Switch Settings and Device Addresses

SW4	SW3	SW2	SW1	A(2:0)	Device Address
OFF	ON	ON	ON	000	\$A0
OFF	ON	ON	OFF	001	\$A2
OFF	ON	OFF	ON	010	\$A4
OFF	ON	OFF	OFF	011	\$A6
OFF	OFF	ON	ON	100	\$A8
OFF	OFF	ON	OFF	101	\$AA (default)
OFF	OFF	OFF	ON	110	\$AC
OFF	OFF	OFF	OFF	111	\$AE

### 5.5 Rear Panel Connectors

The MVME721ET transition module provides these connectors. All connectors use standard pin assignments in compliance with the VMEbus specifications.

*Table 5-4 Transition Module Connectors*

<b>Connector</b>	<b>Function</b>
J1A, J1B, J1C, J1D	COM port connectors
J2A	10/100/1000Mb/s Ethernet connector
J2B	10/100/1000Mb/s Ethernet connector
J10	PIM power/ground
J14	PIM I/O
P2	VME backplane connector

PMC I/O (PIM) connector J10 routes only power and ground from VME P2 connector. There are no host I/O signals on this connector. The MVME7100ET routes PMC I/O from J14 of PMC Slot 1 to VME P2 rows A and C. The MVME721ET routes these signals (pin-for-pin) from VME P2 to PMC I/O module connector J14.

Figure 5-4 Rear Panel Connectors and LEDs

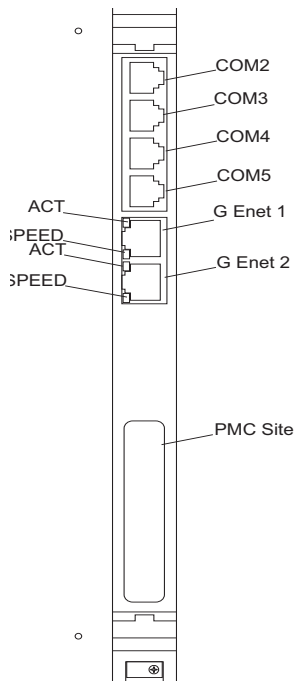

There are two sets of ACT and SPEED LEDs, one set for each Ethernet connector. They are described in the next table.

Table 5-5 Transition Module LEDs

LED	Function
ACT	Activity or Ethernet or Gigabit Ethernet connector
SPEED	10/100/1000Mb/s of Ethernet connectors

## 5.6 PMC Input/Output Module

If a PMC Input/output Module (PIM) has already been installed on the MVME721ET, or you are installing a transition module as it has been shipped from the factory, disregard this procedure and refer to [Transition Module on page 40](#).

### Procedure

For PIM installation, perform the following steps:

## Transition Module

---

1. Attach an ESD strap to your wrist. Attach the other end of the ESD strap to the chassis as a ground. The ESD strap must be secured to your wrist and to ground throughout the procedure.
2. Carefully remove the transition module from its packaging and lay it flat on a stable surface.
3. Remove the PIM filler from the front panel of the transition module.
4. Slide the face plate (front bezel) of the PIM module into the front panel opening from behind and place the PIM module on top of the transition module, aligned with the appropriate two PIM connectors. The two connectors on the underside of the PIM module should then connect smoothly with the corresponding connectors on the transition module (J10 and J14).
5. Insert the four short Phillips screws, provided with the PIM, through the holes on the bottom side of the transition module into the PIM front bezel and rear standoffs. Tighten the screws.

Refer to the following figure for proper screw/board alignment. The example below may not accurately represent your MVME7100ET.

Figure 5-5 Installing the PIM

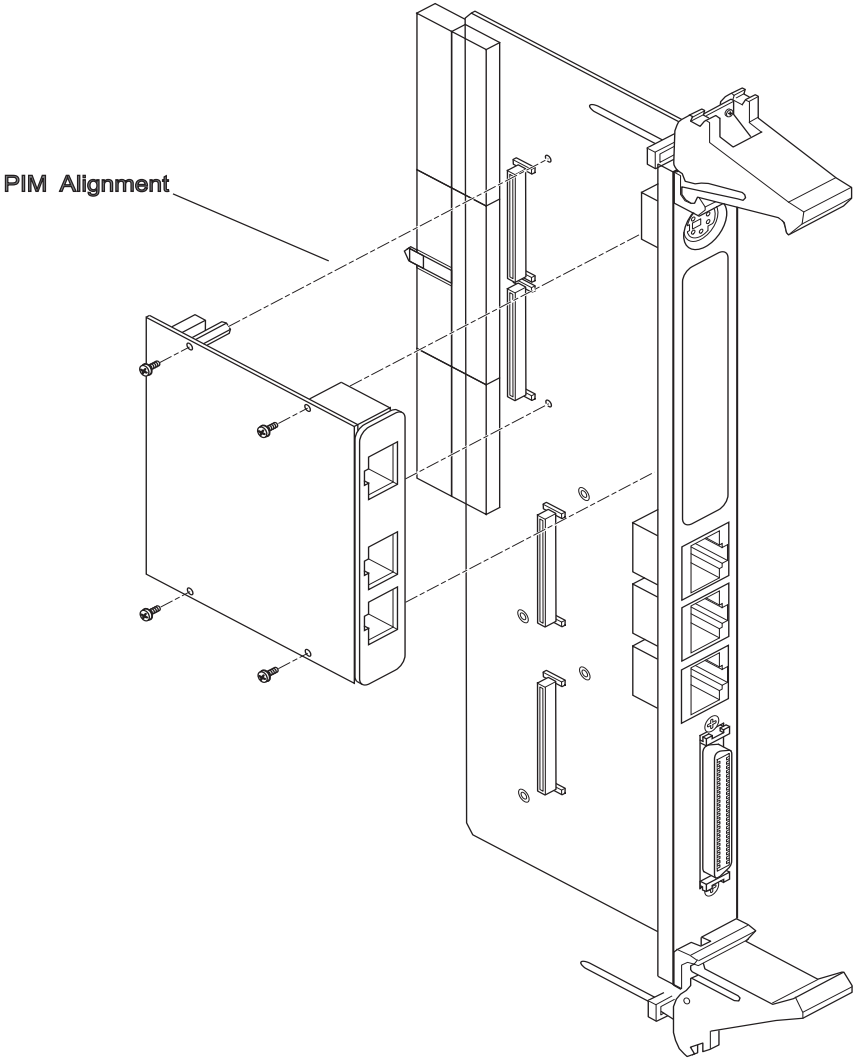





# MOTLoad Firmware

---

## 6.1 Overview

The MOTLoad firmware package serves as a board power-up and initialization package, as well as a vehicle from which user applications can be booted. A secondary function of the MOTLoad firmware is to serve in some respects as a test suite providing individual tests for certain devices. This chapter includes a list of standard MOTLoad commands, the default VME and firmware settings that are changeable by the user, remote start, and the alternate boot procedure.

MOTLoad is controlled through an easy-to-use, UNIX-like, command line interface. The MOTLoad software package is similar to many end-user applications designed for the embedded market, such as the real time operating systems currently available.

Refer to the *MOTLoad Firmware Package User's Manual*, listed in [Appendix B, Related Documentation](#), for more details.

## 6.2 Implementation and Memory Requirements

The implementation of MVME7100ET and its memory requirements are product specific. The MVME7100ET single-board computer (SBC) is offered with a range of memory (for example, DRAM or flash). Typically, the smallest amount of on-board DRAM that a SBC has is 32MB. Each supported product line has its own unique *MVME7100ET* binary image(s). Currently the largest *MVME7100ET* compressed image is less than 1MB in size.

## 6.3 MOTLoad Commands

MVME7100ET supports two types of commands (applications): utilities and tests. Both types of commands are invoked from the MVME7100ET command line in a similar fashion. Beyond that, MVME7100ET utilities and MVME7100ET tests are distinctly different.

### 6.3.1 Utilities

The definition of a MOTLoad utility application is very broad. Simply stated, it is considered a MOTLoad command if it is not a MOTLoad test. Typically, MOTLoad utility applications are applications that aid the user in some way (that is, they do something useful). From the perspective of MOTLoad, examples of utility applications are: configuration, data/status displays, data manipulation, help routines, data/status monitors, etc.

Operationally, MOTLoad utility applications differ from MOTLoad test applications in several ways:

## MOTLoad Firmware

---

Only one utility application operates at any given time (that is, multiple utility applications cannot be executing concurrently).

Utility applications may interact with the user. Most test applications do not.

### 6.3.2 Tests

A MOTLoad test application determines whether or not the hardware meets a given standard. Test applications are validation tests. Validation is conformance to a specification. Most MOTLoad tests are designed to directly validate the functionality of a specific SBC subsystem or component. It is possible for a board's component to fail in the user application but pass specification conformance. These tests validate the operation of such SBC modules as: dynamic memory, external cache, NVRAM, real time clock, etc.

All MOTLoad tests are designed to validate functionality with minimum user interaction. Once launched, most MOTLoad tests operate automatically without any user interaction. There are a few tests where the functionality being validated requires user interaction (that is, switch tests, interactive plug-in hardware modules, etc.). Most MOTLoad test results (error-data/status-data) are logged, not printed. Test results are not preserved and therefore not available to user applications subsequent to their execution. All MOTLoad tests/commands have complete and separate descriptions (refer to the *MOTLoad Firmware Package User's Manual* for this information).

All devices that are available to MOTLoad for validation/verification testing are represented by a unique device path string. Most MOTLoad tests require the operator to specify a test device at the MOTLoad command line when invoking the test.

A listing of all device path strings can be displayed through the `devShow` command. If an SBC device does not have a device path string, it is not supported by MOTLoad and can not be directly tested. There are a few exceptions to the device path string requirement, like testing RAM, which is not considered a true device and can be directly tested without a device path string. Refer to the `devShow` command description page in the *MOTLoad Firmware Package User's Manual*.

Most MOTLoad tests can be organized to execute as a group of related tests (a testSuite) through the use of the `testSuite` command. The expert operator can customize their testing by defining and creating a custom testSuite(s). The list of built-in and user-defined MOTLoad testSuites, and their test contents, can be obtained by entering `testSuite -d` at the MOTLoad prompt. All testSuites that are included as part of a product specific MOTLoad firmware package are product specific. For more information, refer to the `testSuite` command description page in the *MOTLoad Firmware Package User's Manual*.

Test results and test status are obtained through the `testStatus`, `errorDisplay`, and `taskActive` commands. Refer to the appropriate command description page in the *MOTLoad Firmware Package User's Manual* for more information.

### 6.3.3 Command List

The following table provides a list of all current MOTLoad commands. Products supported by MOTLoad may or may not employ the full command set. Typing `help` at the MOTLoad command prompt will display all commands supported by MOTLoad for a given product.

Table 6-1 MOTLoad Commands

Command	Description
as	One-Line Instruction Assembler
bcb bch bcw	Block Compare Byte/Halfword/Word
bdTempShow	Display Current Board Temperature
bfb bfh bfw	Block Fill Byte/Halfword/Word
blkCp	Block Copy
blkFmt	Block Format
blkRd	Block Read
blkShow	Block Show Device Configuration Data
blkVe	Block Verify
blkWr	Block Write
bmb bmh bmw	Block Move Byte/Halfword/Word
br	Assign/Delete/Display User-Program Break-Points
bsb bsh bsw	Block Search Byte/Halfword/Word
bvb bvh bvw	Block Verify Byte/Halfword/Word
cdDir	ISO9660 File System Directory Listing

## MOTLoad Firmware

---

Table 6-1 MOTLoad Commands (continued)

<b>Command</b>	<b>Description</b>
cdGet	ISO9660 File System File Load
clear	Clear the Specified Status/History Table(s)
cm	Turns on Concurrent Mode
csb csh csw	Calculates a Checksum Specified by Command-line Options
devShow	Display (Show) Device/Node Table
diskBoot	Disk Boot (Direct-Access Mass-Storage Device)
downLoad	Down Load S-Record from Host
ds	One-Line Instruction Disassembler
echo	Echo a Line of Text
elfLoader	ELF Object File Loader
errorDisplay	Display the Contents of the Test Error Status Table
eval	Evaluate Expression
execProgram	Execute Program
fatDir	FAT File System Directory Listing
fatGet	FAT File System File Load
fdShow	Display (Show) File Descriptor
flashLock	Flash Memory Sector Lock
flashProgram	Flash Memory Program
flashShow	Display Flash Memory Device Configuration Data
flashUnlock	Flash Memory Sector Unlock
gd	Go Execute User-Program Direct (Ignore Break-Points)
gevDelete	Global Environment Variable Delete

Table 6-1 MOTLoad Commands (continued)

Command	Description
gevDump	Global Environment Variable(s) Dump (NVRAM Header + Data)
gevEdit	Global Environment Variable Edit
gevInit	Global Environment Variable Area Initialize (NVRAM Header)
gevList	Global Environment Variable Labels (Names) Listing
gevShow	Global Environment Variable Show
gn	Go Execute User-Program to Next Instruction
go	Go Execute User-Program
gt	Go Execute User-Program to Temporary Break-Point
hbd	Display History Buffer
hbx	Execute History Buffer Entry
help	Display Command/Test Help Strings
l2CacheShow	Display state of L2 Cache and L2CR register contents
l3CacheShow	Display state of L3 Cache and L3CR register contents
mdb mdh mdw	Memory Display Bytes/Halfwords/Words
memShow	Display Memory Allocation
mmb mmh mmw	Memory Modify Bytes/Halfwords/Words
mpuFork	Execute program from idle processor
mpuShow	Display multi-processor control structure
mpuStart	Start the other MPU
netBoot	Network Boot (BOOT/TFTP)
netShow	Display Network Interface Configuration Data

## MOTLoad Firmware

---

Table 6-1 MOTLoad Commands (continued)

<b>Command</b>	<b>Description</b>
netShut	Disable (Shutdown) Network Interface
netStats	Display Network Interface Statistics Data
noCm	Turns off Concurrent Mode
pciDataRd	Read PCI Device Configuration Header Register
pciDataWr	Write PCI Device Configuration Header Register
pciDump	Dump PCI Device Configuration Header Register
pciShow	Display PCI Device Configuration Header Register
pciSpace	Display PCI Device Address Space Allocation
ping	Ping Network Host
portSet	Port Set
portShow	Display Port Device Configuration Data
rd	User Program Register Display
reset	Reset System
rs	User Program Register Set
set	Set Date and Time
sromRead	SROM Read
sromWrite	SROM Write
sta	Symbol Table Attach
stl	Symbol Table Lookup
stop	Stop Date and Time (Power-Save Mode)
taskActive	Display the Contents of the Active Task Table
tc	Trace (Single-Step) User Program
td	Trace (Single-Step) User Program to Address
testDisk	Test Disk

Table 6-1 MOTLoad Commands (continued)

Command	Description
testEnetPtP	Ethernet Point-to-Point
testNvramRd	NVRAM Read
testNvramRdWr	NVRAM Read/Write (Destructive)
testRam	RAM Test (Directory)
testRamAddr	RAM Addressing
testRamAlt	RAM Alternating
testRamBitToggle	RAM Bit Toggle
testRamBounce	RAM Bounce
testRamCodeCopy	RAM Code Copy and Execute
testRamEccMonitor	Monitor for ECC Errors
testRamMarch	RAM March
testRamPatterns	RAM Patterns
testRamPerm	RAM Permutations
testRamQuick	RAM Quick
testRamRandom	RAM Random Data Patterns
testRtcAlarm	RTC Alarm
testRtcReset	RTC Reset
testRtcRollOver	RTC Rollover
testRtcTick	RTC Tick
testSerialExtLoop	Serial External Loopback
testSerialIntLoop	Serial Internal Loopback
testStatus	Display the Contents of the Test Status Table
testSuite	Execute Test Suite

## MOTLoad Firmware

---

Table 6-1 MOTLoad Commands (continued)

Command	Description
testSuiteMake	Make (Create) Test Suite
testWatchdogTimer	Tests the Accuracy of the Watchdog Timer Device
tftpGet	TFTP Get
tftpPut	TFTP Put
time	Display Date and Time
transparentMode	Transparent Mode (Connect to Host)
tsShow	Display Task Status
upLoad	Up Load Binary Data from Target
version	Display Version String(s)
vmeCfg	Manages user specified VME configuration parameters
vpdDisplay	VPD Display
vpdEdit	VPD Edit
wait	Wait for Test Completion
waitProbe	Wait for I/O Probe to Complete

## 6.4 Using the Command Line Interface

Interaction with MOTLoad is performed via a command line interface through a serial port on the single board computer, which is connected to a terminal or terminal emulator (for example, Window's Hypercomm). The default MOTLoad serial port settings are: 9600 baud, 8 bits, no parity.

The MOTLoad command line interface is similar to a UNIX command line shell interface. Commands are initiated by entering a valid MOTLoad command (a text string) at the MOTLoad command line prompt and pressing the carriage-return key to signify the end of input. MOTLoad then performs the specified action. An example of a MOTLoad command line prompt is shown below. The MOTLoad prompt changes according to what product it is used on (for example, MVME6100, MVME3100, MVME7100).

Example:

```
MVME7100>
```



If an invalid MOTLoad command is entered at the MOTLoad command line prompt, MOTLoad displays a message that the command was not found.

Example:

```
MVME7100> mytest
"mytest" not found
MVME7100>
```

If the user enters a partial MOTLoad command string that can be resolved to a unique valid MOTLoad command and presses the carriage-return key, the command is executed as if the entire command string had been entered. This feature is a user-input shortcut that minimizes the required amount of command line input. MOTLoad is an ever changing firmware package, so user-input shortcuts may change as command additions are made.

Example:

```
MVME7100>[ver]sion
Copyright: Motorola Inc.1999-2005, All Rights Reserved
MOTLoad RTOS Version 2.0, PAL Version 1.0 RM01
Mon Aug 29 15:24:13 MST 2005
MVME7100>
```

Example:

```
MVME7100> ver
Copyright: Motorola Inc.1999-2005, All Rights Reserved
MOTLoad RTOS Version 2.0, PAL Version 1.0 RM01
Mon Aug 29 15:24:13 MST 2005
MVME7100>
```

If the partial command string cannot be resolved to a single unique command, MOTLoad informs the user that the command was ambiguous.

Example:

```
MVME7100> te
"te" ambiguous
MVME7100>
```

### 6.4.1 Rules

There are a few things to remember when entering a MOTLoad command:

- Multiple commands are permitted on a single command line, provided they are separated by a single semicolon (;).
- Spaces separate the various fields on the command line (command/arguments/options).

## MOTLoad Firmware

---

- The argument/option identifier character is always preceded by a hyphen (-) character.
- Options are identified by a single character.
- Option arguments immediately follow (no spaces) the option.
- All commands, command options, and device tree strings are case sensitive.

Example:

```
MVME7100> flashProgram -d/dev/flash0 -n00100000
```

For more information on MOTLoad operation and function, refer to the *MOTLoad Firmware Package User's Manual*.

### 6.4.2 Help

Each MOTLoad firmware package has an extensive, product-specific help facility that can be accessed through the `help` command. The user can enter `help` at the MOTLoad command line to display a complete listing of all available tests and utilities.

Example:

```
MVME7100> help
```

For help with a specific test or utility the user can enter the following at the MOTLoad prompt:

```
help <command_name>
```

The `help` command also supports a limited form of pattern matching. Refer to the `help` command page.

Example:

```
MVME7100> help testRam
```

```
Usage: testRam [-aPh] [-bPh] [-iPd] [-nPh] [-tPd] [-v]
```

```
Description: RAM Test [Directory]
```

```
Argument/Option Description
```

```
-a Ph: Address to Start (Default = Dynamic Allocation)
```

```
-b Ph: Block Size (Default = 16KB)
```

```
-i Pd: Iterations (Default = 1)
```

```
-n Ph: Number of Bytes (Default = 1MB)
```

```
-t Ph: Time Delay Between Blocks in OS Ticks (Default = 1)
```

```
-v O : Verbose Output
```

```
MVME7100>
```

## 6.5 Firmware Settings

The following sections provide additional information pertaining to the MVME7100ET VME bus interface settings as configured by MOTLoad. A few VME settings are controlled by hardware jumpers while the majority of the VME settings are managed by the firmware command utility `vmeCfg`.



**VME settings in MOTLoad are preserved through the use of Global Environment Variables (GEVs). Configuration GEVs are executed only at power-on reset. Therefore, if VME configuration changes are implemented through `vmeCfg` and board reset must be effected for the changes to be implemented in MOTLoad.**

### 6.5.1 Default VME Settings

As shipped from the factory, the MVME7100ET has the following VME configuration programmed via Global Environment Variables (GEVs) for the Tsi148 VME controller. The firmware allows certain VME settings to be changed in order for the user to customize the environment. The following is a description of the default VME settings that are changeable by the user. For more information, refer to the *MOTLoad User's Manual* and Tundra's *Tsi148 User Manual*, listed in [Appendix B, Related Documentation](#).

- MVME7100> `vmeCfg -s -m`  
 Displaying the selected Default VME Setting  
 - interpreted as follows:  
 VME PCI Master Enable [Y/N] = Y  
 MVME7100>

The PCI Master is enabled.

- MVME7100> `vmeCfg -s -r234`  
 Displaying the selected Default VME Setting  
 - interpreted as follows:  
 VMEbus Master Control Register = 00000003  
 MVME7100>

The VMEbus Master Control Register is set to the default (RESET) condition.

- MVME7100> `vmeCfg -s -r238`  
 Displaying the selected Default VME Setting  
 - interpreted as follows:  
 VMEbus Control Register = 00000008  
 MVME7100>

The VMEbus Control Register is set to a Global Timeout of 2048  $\mu$ seconds.

## MOTLoad Firmware

---

- MVME7100> **vmeCfg -s -r414**

```
Displaying the selected Default VME Setting
- interpreted as follows:
CRG Attribute Register = 00000000
CRG Base Address Upper Register = 00000000
CRG Base Address Lower Register = 00000000
MVME7100>
```

The CRG Attribute Register is set to the default (RESET) condition.

- MVME7100> **vmeCfg -s -i0**

```
Displaying the selected Default VME Setting
- interpreted as follows:
Inbound Image 0 Attribute Register = 000227AF
Inbound Image 0 Starting Address Upper Register = 00000000
Inbound Image 0 Starting Address Lower Register = 00000000
Inbound Image 0 Ending Address Upper Register = 00000000
Inbound Image 0 Ending Address Lower Register = 1FFF0000
Inbound Image 0 Translation Offset Upper Register = 00000000
Inbound Image 0 Translation Offset Lower Register = 00000000
MVME7100>
```

Inbound window 0 (ITAT0) is not enabled; Virtual FIFO at 256 bytes, 2eSST timing at SST320, respond to 2eSST, 2eVME, MBLT, and BLT cycles, A32 address space, respond to Supervisor, User, Program, and Data cycles. Image maps from 0x00000000 to 0x1FFF0000 on the VMEbus, translates 1x1 to the PCI-X bus (thus 1x1 to local memory). To enable this window, set bit 31 of ITAT0 to 1.

- MVME7100> **vmeCfg -s -o1**

```
Displaying the selected Default VME Setting
- interpreted as follows:
Outbound Image 1 Attribute Register = 80001462
Outbound Image 1 Starting Address Upper Register = 00000000
Outbound Image 1 Starting Address Lower Register = 91000000
Outbound Image 1 Ending Address Upper Register = 00000000
Outbound Image 1 Ending Address Lower Register = AFFF0000
Outbound Image 1 Translation Offset Upper Register = 00000000
Outbound Image 1 Translation Offset Lower Register = 70000000
Outbound Image 1 2eSST Broadcast Select Register = 00000000
MVME7100>
```

Outbound window 1 (OTAT1) is enabled, 2eSST timing at SST320, transfer mode of 2eSST, A32/D32 Supervisory access. The window accepts transfers on

the PCI-X Local Bus from 0x91000000-0xAFFF0000 and translates them onto the VMEbus using an offset of 0x70000000, thus an access to 0x91000000 on the PCI-X Local Bus becomes an access to 0x01000000 on the VMEbus.

- MVME7100> **vmeCfg -s -o2**

Displaying the selected Default VME Setting

- interpreted as follows:

```
Outbound Image 2 Attribute Register = 80001061
Outbound Image 2 Starting Address Upper Register = 00000000
Outbound Image 2 Starting Address Lower Register = B0000000
Outbound Image 2 Ending Address Upper Register = 00000000
Outbound Image 2 Ending Address Lower Register = B0FF0000
Outbound Image 2 Translation Offset Upper Register = 00000000
Outbound Image 2 Translation Offset Lower Register = 40000000
Outbound Image 2 2eSST Broadcast Select Register = 00000000
MVME7100>
```

Outbound window 2 (OTAT2) is enabled, 2eSST timing at SST320, transfer mode of SCT, A24/D32 Supervisory access. The window accepts transfers on the PCI-X Local Bus from 0xB0000000-0xB0FF0000 and translates them onto the VMEbus using an offset of 0x40000000, thus an access to 0xB0000000 on the PCI-X Local Bus becomes an access to 0xF0000000 on the VMEbus.

- MVME7100> **vmeCfg -s -o3**

Displaying the selected Default VME Setting

- interpreted as follows:

```
Outbound Image 3 Attribute Register = 80001061
Outbound Image 3 Starting Address Upper Register = 00000000
Outbound Image 3 Starting Address Lower Register = B3FF0000
Outbound Image 3 Ending Address Upper Register = 00000000
Outbound Image 3 Ending Address Lower Register = B3FF0000
Outbound Image 3 Translation Offset Upper Register = 00000000
Outbound Image 3 Translation Offset Lower Register = 4C000000
Outbound Image 3 2eSST Broadcast Select Register = 00000000
MVME7100>
```

Outbound window 3 (OTAT3) is enabled, 2eSST timing at SST320, transfer mode of SCT, A16/D32 Supervisory access. The window accepts transfers on the PCI-X Local Bus from 0xB3FF0000-0xB3FF0000 and translates them onto the VMEbus using an offset of 0x4C000000, thus an access to 0xB3FF0000 on the PCI-X Local Bus becomes an access to 0xFFFF0000 on the VMEbus.

- MVME7100> **vmeCfg -s -o7**  
Displaying the selected Default VME Setting  
- interpreted as follows:  
Outbound Image 7 Attribute Register = 80001065  
Outbound Image 7 Starting Address Upper Register = 00000000  
Outbound Image 7 Starting Address Lower Register = B1000000  
Outbound Image 7 Ending Address Upper Register = 00000000  
Outbound Image 7 Ending Address Lower Register = B1FF0000  
Outbound Image 7 Translation Offset Upper Register = 00000000  
Outbound Image 7 Translation Offset Lower Register = 4F000000  
Outbound Image 7 2eSST Broadcast Select Register = 00000000  
MVME7100>

Outbound window 7 (OTAT7) is enabled, 2eSST timing at SST320, transfer mode of SCT, CR/CSR Supervisory access. The window accepts transfers on the PCI-X Local Bus from 0xB1000000-0xB1FF0000 and translates them onto the VMEbus using an offset of 0x4F000000, thus an access to 0xB1000000 on the PCI-X Local Bus becomes an access to 0x00000000 on the VMEbus.

### 6.5.2 Control Register/Control Status Register Settings

The CR/CSR base address is initialized to the appropriate setting based on the Geographical address; that is, the VME slot number. See the VME64 Specification and the VME64 Extensions for details. As a result, a 512KB CR/CSR area can be accessed from the VMEbus using the CR/CSR AM code.

### 6.5.3 Displaying VME Settings

To display the changeable VME setting, type the following at the firmware prompt:

- To display Master Enable state:  
**vmeCfg -s -m**
- To display selected Inbound Window state:  
**vmeCfg -s -i(0 - 7)**
- To display selected Outbound Window state:  
**vmeCfg -s -o(0 - 7)**
- To display Master Control Register state:  
**vmeCfg -s -r234**
- To display Miscellaneous Control Register state:  
**vmeCfg -s -r238**

- To display CRG Attribute Register state:  
`vmeCfg -s -r414`

## 6.5.4 Editing VME Settings

To edit the changeable VME setting, type the following at the firmware prompt:

- Edits Master Enable state:  
`vmeCfg -e -m`
- Edits selected Inbound Window state:  
`vmeCfg -e -i(0 - 7)`
- Edits selected Outbound Window state:  
`vmeCfg -e -o(0 - 7)`
- Edits Master Control Register state:  
`vmeCfg -e -r234`
- Edits Control Register state:  
`vmeCfg -e -r238`
- Edits CRG Attribute Register state:  
`vmeCfg -e -r414`

## 6.5.5 Deleting VME Settings

To delete the changeable VME setting (restore default value), type the following at the firmware prompt:

- Deletes Master Enable state:  
`vmeCfg -d -m`
- Deletes selected Inbound Window state:  
`vmeCfg -d -i(0 - 7)`
- Deletes selected Outbound Window state:  
`vmeCfg -d -o(0 - 7)`
- Deletes Master Control Register state:  
`vmeCfg -d -r234`
- Deletes Control Register state:  
`vmeCfg -d -r238`
- Deletes CRG Attribute Register state:  
`vmeCfg -d -r414`

### 6.5.6 Restoring Default VME Settings

To restore all of the changeable VME setting back to their default settings, type the following at the firmware prompt:

```
vmeCfg -z
```

## 6.6 Remote Start

As described in the *MOTLoad Firmware Package User's Manual*, listed in [Appendix B, Related Documentation](#), remote start allows the user to obtain information about the target board, download code and/or data, modify memory on the target, and execute a downloaded program. These transactions occur across the VMEbus in the case of the MVME7100ET. MOTLoad uses one of four mailboxes in the Tsi148 VME controller as the inter-board communication address (IBCA) between the host and the target.

CR/CSR slave addresses configured by MOTLoad are assigned according to the installation slot in the backplane, as indicated by the *VME64 Specification*. For reference, the following values are provided:

CS/CSR Starting Address	Slot Position
1	0x0008.0000
2	0x0010.0000
3	0x0018.0000
4	0x0020.0000
5	0x0028.0000
6	0x0030.0000
7	0x0038.0000
8	0x0040.0000
9	0x0048.0000
A	0x0050.0000
B	0x0058.0000
C	0x0060.0000

For further details on CR/CSR space, please refer to the *VME64 Specification*, listed in [Appendix B, Related Documentation](#).



The MVME7100ET uses a TSi148 for its PCI/X-to-VME bus bridge. The offsets of the mailboxes in the TSi148 are defined in the *TSi148 VMEBus PCI/X-to-VME User Manual*, listed in [Appendix B, Related Documentation](#), but are noted here for reference:

- Mailbox 0 is at offset 7f610 in the CR/CSR space
- Mailbox 1 is at offset 7f614 in the CR/CSR space
- Mailbox 2 is at offset 7f618 in the CR/CSR space
- Mailbox 3 is at offset 7f61C in the CR/CSR space

The selection of the mailbox used by remote start on an individual MVME7100ET is determined by the setting of a global environment variable (GEV). The default mailbox is zero. Another GEV controls whether remote start is enabled (default) or disabled. Refer to the *Remote Start* appendix in the *MOTLoad Firmware Package User's Manual* for remote start GEV definitions.

The MVME7100ETs IBCA needs to be mapped appropriately through the master's VMEbus bridge. For example, to use remote start using mailbox 0 on an MVME7100ET installed in slot 5, the master would need a mapping to support reads and writes of address 0x002ff610 in VME CR/CSR space (0x280000 + 0x7f610).

## 6.7 Boot Images

Valid boot images whether POST, USER, or Alternate MOTLoad, are located on 1 MB boundaries within the upper 8 MB of flash. The image may exceed 1 MB in size. An image is determined valid through the presence of two "valid image keys" and other sanity checks. A valid boot image begins with a structure as defined in the following table:

Name	Type	Size	Notes
UserDefined	unsigned integer	8	User defined
ImageKey 1	unsigned integer	1	0x414c5420
ImageKey 2	unsigned integer	1	0x424f4f54
ImageChecksum	unsigned integer	1	Image checksum
ImageSize	unsigned integer	1	Must be a multiple of 4
ImageName	unsigned character	20	User defined
ImageRamAddress	unsigned integer	1	RAM address
ImageOffset	unsigned integer	1	Offset from header start to entry
ImageFlags	unsigned integer	1	Refer to <a href="#">Image Flags on page 106</a>
ImageVersion	unsigned integer	1	User defined
Reserved	unsigned integer	8	Reserved for expansion

### 6.7.1 Checksum Algorithm

The checksum algorithm is a simple unsigned word add of each word (4 byte) location in the image. The image must be a multiple of 4 bytes in length (word-aligned). The content of the checksum location in the header is not part of the checksum calculation. The calculation assumes the location to be zero. The algorithm is implemented using the following code:

```
Unsigned int checksum(  
    Unsigned int *startPtr, /* starting address */  
    Unsigned int endPtr /* ending address */  
    ) {  
    unsigned int checksum=0;  
    while (startPtr < endPtr) {  
        checksum += *startPtr;  
        startPtr++;  
    }  
    return(checksum);  
}
```

### 6.7.2 Image Flags

The image flags of the header define various bit options that control how the image will be executed.

Table 6-2 MOTLoad Image Flags

Name	Value	Interpretation
COPY_TO_RAM	0x00000001	Copy image to RAM at <b>ImageRamAddress</b> before execution
IMAGE_MCG	0x00000002	Alternate MOTLoad image
IMAGE_POST	0x00000004	POST image
DONT_AUTO_RUN	0x00000008	Image <b>not</b> to be executed

#### **COPY\_TO\_RAM**

If set, this flag indicates that the image is to be copied to RAM at the address specified in the header before control is passed. If not set, the image will be executed in flash. In both instances, control will be passed at the image offset specified in the header from the base of the image.

#### **IMAGE\_MCG**

If set, this flag defines the image as being an Alternate MOTLoad, as opposed to USER, image. This bit should not be set by developers of alternate boot images.

### IMAGE\_POST

If set, this flag defines the image as being a power-on self-test image. This bit flag is used to indicate that the image is a diagnostic and should be run prior to running either USER or MCG boot images. POST images are expected, but not required, to return to the boot block code upon completion.

### DONT\_AUTO\_RUN

If set, this flag indicates that the image is not to be selected for automatic execution. A user, through the interactive command facility, may specify the image to be executed.



**MOTLoad currently uses an Image Flag value of 0x3, which identifies itself as an Alternate MOTLoad image that executes from RAM. MOTLoad currently does not support execution from flash.**

## 6.7.3 User Images

These images are user-developer boot code; for example, a VxWorks bootrom image. Such images may expect the system software state to be as follows upon entry:

The MMU is disabled.

- L1 instruction cache has been initialized and is enabled.
- L1 data cache has been initialized (invalidated) and is disabled.
- L2 cache is disabled.
- L3 cache is disabled.
- RAM has been initialized and is mapped starting at CPU address 0.
- If RAM ECC or parity is supported, RAM has been scrubbed of ECC or parity errors.
- The active flash bank (boot) is mapped from the upper end of the address space.
- If specified by COPY\_TO\_RAM, the image has been copied to RAM at the address specified by **ImageRamAddress**.
- CPU register R1 (the stack pointer) has been initialized to a value near the end of RAM.
- CPU register R3 is added to the following structure:

```
typedef struct altBootData {
    unsigned int ramSize; /* board's RAM size in MB */
    void flashPtr; /* ptr to this image in flash */
    char boardType[16]; /* name string, eg MVME7100 */
    void globalData; /* 16K, zeroed, user defined */
    unsigned int reserved[12];
} altBootData_t;
```

### 6.7.4 Alternate Boot Data Structure

The globalData field of the alternate boot data structure points to an area of RAM which was initialized to zeroes by the boot loader. This area of RAM is not cleared by the boot loader after execution of a POST image, or other alternate boot image, is executed. It is intended to provide a user a mechanism to pass POST image results to subsequent boot images.

The boot loader performs no other initialization of the board than that specified prior to the transfer of control to either a POST, USER, or Alternate MOTLoad image. Alternate boot images need to initialize the board to whatever state the image may further require for its execution.

POST images are expected, but not required, to return to the boot loader. Upon return, the boot loader proceeds with the scan for an executable alternate boot image. POST images that return control to the boot loader must ensure that upon return, the state of the board is consistent with the state that the board was in at POST entry. USER images should not return control to the boot loader.

### 6.7.5 Alternate Boot Images and Safe Start

Some later versions of MOTLoad support alternate boot images and a safe start recovery procedure. If safe start is available on the MVME7100ET, alternate boot images are supported. With alternate boot image support, the boot loader code in the boot block examines the upper 8 MB of the flash bank for alternate boot images. If an image is found, control is passed to the image.

### 6.7.6 Boot Image Firmware Scan

The scan is performed by examining each 1 MB boundary for a defined set of flags that identify the image as being POST, USER, or Alternate MOTLoad. POST is a user-developed Power On Self Test that would perform a set of diagnostics and then return to the boot loader image. USER would be a boot image, such as the VxWorks bootrom, which

would perform board initialization. A bootable VxWorks kernel would also be a USER image. Boot images are not restricted to being 1 MB or less in size; however, they must begin on a 1 MB boundary within the 8 MB of the scanned flash bank. The flash bank structure is shown below:

Address	Usage
0xFFF00000 to 0xFFFFFFFF	Boot block. Recovery code.
0xFFE00000 to 0xFFFFFFFF	Backup MOTLoad image
0xFFD00000 to 0xFFDFFFFFF	First possible alternate image
0xFFC00000 to 0xFFCFFFFFF	Second possible alternate image
....	Alternate boot images
0xFF899999 to 0xFF8FFFFFF	Bottom of flash (flash size varies per product)

The scan is performed downwards beginning at the location of the first possible alternate image and searches first for POST, then USER, and finally Alternate MOTLoad images. In the case of multiple images of the same type, control is passed to the first image encountered in the scan.

Safe Start, whether invoked by hitting **ESC** on the console within the first five seconds following power-on reset or by setting the Safe Start jumper, interrupts the scan process. The user may then display the available boot images and select the desired image. The feature is provided to enable recovery in cases when the programmed Alternate Boot Image is no longer desired. The following output is an example of an interactive Safe Start:

```
ABCDEInteractive Boot Mode Entered
```

```
boot> ?
```

```
Interactive boot commands:
```

```
'd':show directory of alternate boot images
```

```
'c':continue with normal startup
```

```
'q':quit without executing any alternate boot image
```

```
'r [address]':execute specified (or default) alternate image
```

```
'p [address]':execute specified (or default) POST image
```

```
'?':this help screen
```

```
'h':this help screen
```

```
boot> d
```

```
Addr FFE00000 Size 00100000 Flags 00000003 Name: MOTLoad
```

```
Addr FFD00000 Size 00100000 Flags 00000003 Name: MOTLoad
```

```
boot> c
```

```
NOPQRSTUVWXYZabcdefghijklmnopqrsstuvwxyzWXXZ
```

```
Copyright Motorola Inc. 1999-2004, All Rights Reserved
```

```
MOTLoad RTOS Version 2.0, PAL Version 0.b EA02
```

...

MVME7100>

## 6.8 Startup Sequence

The firmware startup sequence following reset of MOTLoad is to:

- Initialize cache, MMU, FPU, and other CPU internal items
- Initialize the memory controller
- Search the active flash bank, possibly interactively, for a valid Power On Self Test (POST) image. If found, the POST image executes. Once completed, the POST image returns and startup continues.
- Search the active flash bank, possibly interactively, for a valid USER boot image. If found, the USER boot image executes. A return to the boot block code is not anticipated.
- If a valid USER boot image is not found, search the active flash bank, possibly interactively, for a valid Alternate MOTLoad boot image; anticipated to be an upgrade of alternate MOTLoad firmware. If found, the image is executed. A return to the boot block code is not anticipated.
- Execute the recovery image of the firmware in the boot block if no valid USER or alternate MOTLoad image is found

During startup, interactive mode may be entered by either setting the Safe Start jumper/switch or by sending an <ESC> to the console serial port within five seconds of the board reset. During interactive mode, the user has the option to display locations at which valid boot images were discovered, specify which discovered image is to be executed, or specify that the recovery image in the boot block of the active flash bank is to be executed.

# Battery Exchange

## A.1 Battery Exchange

Some blade variants contain an on-board battery. The battery location is shown in the following figure.

*Figure A-1 Battery Location*

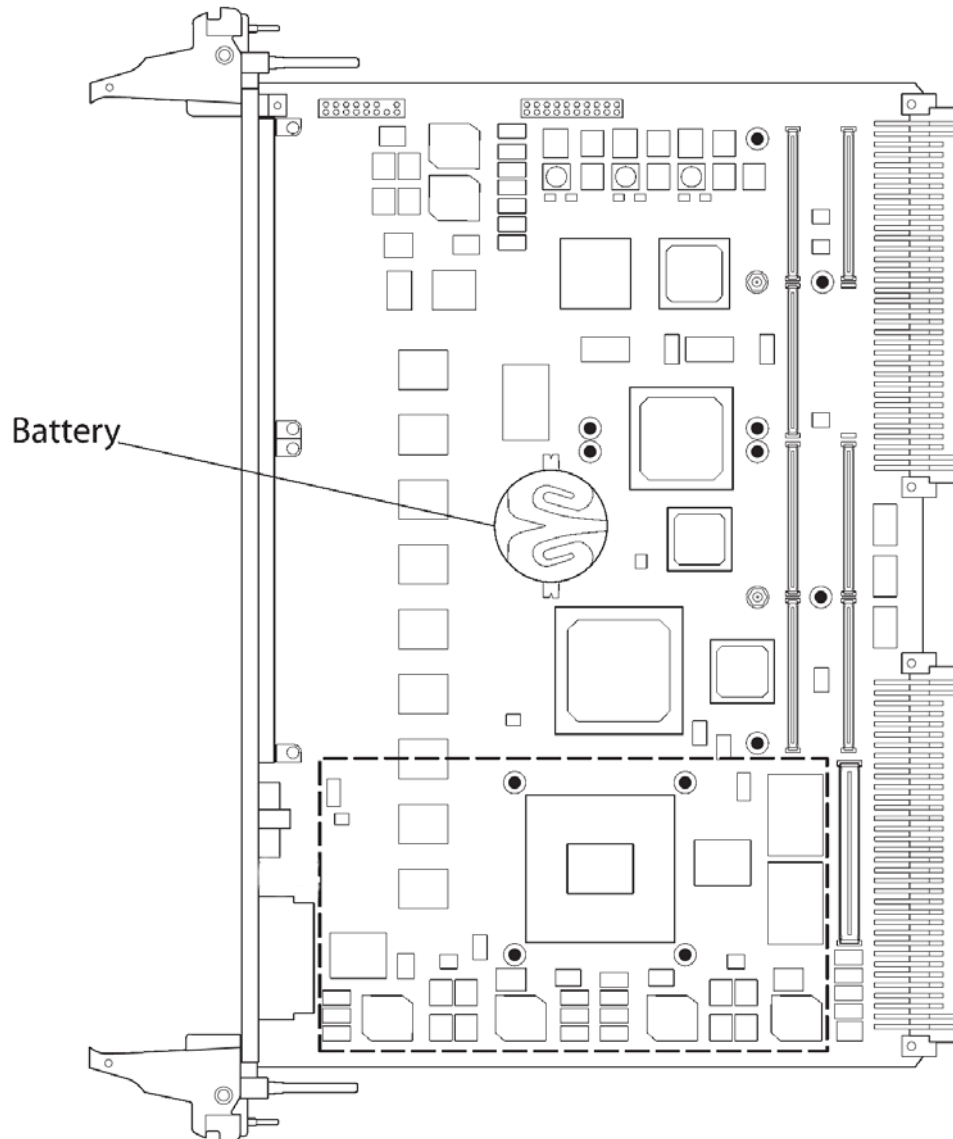

## Battery Exchange

---

The battery provides data retention of seven years summing up all periods of actual data use. Penguin Solutions therefore assumes that there usually is no need to exchange the battery except, for example, in case of long-term spare part handling.

### **NOTICE**

#### **Board/System Damage**

**Incorrect exchange of lithium batteries can result in a hazardous explosion.**

**When exchanging the on-board lithium battery, make sure that the new and the old battery**

**are from exactly the same battery manufacturer and of the same models.**

**If the respective battery model is not available, contact your local Penguin Solutions sales**

**representative for the availability of alternative, officially approved battery models.**

#### **Data Loss**

**Exchanging the battery can result in loss of time settings. Backup power prevents the loss of data during exchange.**

**Quickly replacing the battery may save time settings.**

#### **Data Loss**

**If the battery has low or insufficient power the RTC is initialized.**

**Exchange the battery before seven years of actual battery use have elapsed.**

#### **PCB and Battery Holder Damage**

**Removing the battery with a screw driver may damage the PCB or the battery holder. To prevent damage, do not use a screw driver to remove the battery from its holder.**

### **Exchange Procedure**

To exchange the battery, proceed as follows:

1. Remove the old battery.
2. Install the new battery with the plus sign (+) facing up.
3. Dispose of the old battery according to your country's legislation and in an environmentally safe way.



Important  
Information

**The RTC field removable battery should be removed, if MVME7100ET has to be stored beyond its operational temperature range.**



# Related Documentation

## B.1 Penguin Solutions Documentation

Technical documentation can be found by using the Documentation Search at <https://www.penguinsolutions.com/edge/support/> or you can obtain electronic copies of documentation by contacting your local sales representative.

*Table B-1 Penguin Solutions Documentation*

Document Title	Document Number
MVME7100 Data Sheet	MVME7100-DS
MVME7100ET Single Board Computer Programmer's Reference	6806800K88
MOTLoad Firmware Package User's Manual	6806800C24
XMCspan Installation and Use	6806800H03

## B.2 Manufacturers' Documents

For additional information, refer to the following table for manufacturers' data sheets or user's manuals. As an additional help, a source for the listed document is provided. Please note that, while these sources have been verified, the information is subject to change without notice.

*Table B-2 Manufacturer's Publications*

Document Title and Source	Publication Number
<b>AMD</b>	
<b>Data Sheet</b> S29GLxxxN MirrorBit™ Flash Family S29GL512N, S29GL256N, S29GL128N 512 Megabit, 256 Megabit, and 128 Megabit, 3.0 Volt-only Page Mode Flash Memory featuring 110 nm MirrorBit process technology	Revision A Amendment 4 May 13, 2004
<b>Atmel Corporation</b>	
2-Wire Serial EEPROM 32K (4096 x 8), 64K (8192 x 8) AT24C32C, AT24C64C	5174B-SEEPR-12/06
2-Wire Serial EEPROM 512K (65,536 x 8) AT24C512	Rev. 1116K-SEEPR-1/04

Table B-2 *Manufacturer's Publications (continued)*

Document Title and Source	Publication Number
<b>NXP Corporation</b>	
MC864xD Integrated Host Processor Reference Manual	
MC864xD Errata	
MC864xD Integrated Processor Hardware Specifications	
NXP 512 MB MRAM	
<b>Texas Instruments</b>	
<b>Data Sheet</b> SN74VMEH22501A 8-bit Universal Bus Transceiver and Two 1-bit Bus Transceivers with Split LVTTTL Port, Feedback Path, and 3-state Outputs	SCES620 Revised Dec 2004
<b>Exar</b>	
ST16C554DIQ64 Quad UART with 16-Byte FIFO's	Version 4.0.1 June 2006
<b>Maxim Integrated Products</b>	
DS1375 Serial Real-Time Clock	REV: 121203
MAX3243EEAI $\pm 15$ kV ESD-Protected, 1 $\mu$ A, 3.0V to 5.5V, 250kbps,RS-232 Transceivers with AutoShutdown	19-1283 Rev 6 9/05
MAX811/MAX812 4-Pin $\mu$ P Voltage Monitors With Manual Reset Input	19-0411 Rev 3 3/99
On Semi device ADT7461	ADT7461/D, Rev 4, January 2009
<b>IDT</b>	
Tsi148-133ILY PCI/X-to-VME Bus Bridge User Manual	FN 80A3020 MA001_13

*Table B-2 Manufacturer's Publications (continued)*

<b>Document Title and Source</b>	<b>Publication Number</b>
<b>Broadcom Corporation</b>	
BCM5482S 10/100/1000BASE-T Gigabit Ethernet Transceiver	5482S-DS09-R 2/13/09
<b>PLX Technology</b>	
PEX8112AA ExpressLane PCI Express-to-PCI Bridge Data Book	Version 1.2
ExpressLane PEX 8114BC PCI Express-to-PCI/PCI-X Bridge Data Book	Version 3.0
ExpressLane PEX 8525AA 5-Port/24-Lane Versatile PCI Express Switch Data Book	Version 0.95

## B.3 Related Specifications

For additional information, refer to the following table for related specifications. As an additional help, a source for the listed document is provided. Please note that, while these sources have been verified, the information is subject to change without notice.

*Table B-3 Related Specifications*

<b>Organization and Standard</b>	<b>Document Title</b>
<b>VITA Standards Organization</b>	
VME64	ANSI/VITA 1-1994
VME64 Extensions	ANSI/VITA 1.1-1997
2eSST Source Synchronous Transfer	ANSI/VITA 1.5-2003
Processor PMC	ANSI/VITA 32-2003
PCI-X for PMC and Processor PMC	ANSI/VITA 39-2003
PMC I/O Module (PIM) Draft Standard	VITA 36 Draft Rev 0.1 July 19, 1999

*Table B-3 Related Specifications (continued)*

<b>Organization and Standard</b>	<b>Document Title</b>
<b>Universal Serial Bus</b>	
Universal Serial Bus Specification	Revision 2.0 April 27, 2000
<b>PCI Special Interest Group</b>	
PCI Local Bus Specification, Revision 2.2	PCI Rev 2.2 December 18, 1998
PCI-X Electrical and Mechanical Addendum to the PCI Local Bus Specification, Revision 2.0a	PCI-X EM 2.0a August 22, 2003
PCI-X Protocol Addendum to the PCI Local Bus Specification, Revision 2.0a	PCI-X PT 2.0a July 22, 2003
<b>Institute for Electrical and Electronics Engineers, Inc.</b>	
Draft Standard for a Common Mezzanine Card Family: CMC	P1386 - 2001
Draft Standard Physical and Environmental Layer for PCI Mezzanine Cards: PMC	P1386 - 2001



# PENGUIN<sup>™</sup>

SOLUTIONS 

Penguin Solutions is a trade name used by SMART Embedded Computing, Inc., a wholly owned subsidiary of SMART Global Holdings, Inc. Penguin Edge is a trademark owned by Penguin Computing, Inc., a wholly owned subsidiary of SMART Global Holdings, Inc. All other logos, trade names, and trademarks are the property of their respective owners. ©2022 SMART Embedded Computing, Inc.