



Penguin Edge™ MVME3100

Installation and Use

P/N: 6806800M28J

July 2022



Legal Disclaimer*

SMART Embedded Computing, Inc. (SMART EC), dba Penguin Solutions™, assumes no responsibility for errors or omissions in these materials. **These materials are provided "AS IS" without warranty of any kind, either expressed or implied, including but not limited to, the implied warranties of merchantability, fitness for a particular purpose, or non-infringement.** SMART EC further does not warrant the accuracy or completeness of the information, text, graphics, links, or other items contained within these materials. SMART EC shall not be liable for any special, indirect, incidental, or consequential damages, including without limitation, lost revenues or lost profits, which may result from the use of these materials. SMART EC may make changes to these materials, or to the products described therein, at any time without notice. SMART EC makes no commitment to update the information contained within these materials.

Electronic versions of this material may be read online, downloaded for personal use, or referenced in another document as a URL to a SMART EC website. The text itself may not be published commercially in print or electronic form, edited, translated, or otherwise altered without the permission of SMART EC.

It is possible that this publication may contain reference to or information about SMART EC products, programming, or services that are not available in your country. Such references or information must not be construed to mean that SMART EC intends to announce such SMART EC products, programming, or services in your country.

Limited and Restricted Rights Legend

If the documentation contained herein is supplied, directly or indirectly, to the U.S. Government, the following notice shall apply unless otherwise agreed to in writing by SMART EC.

Use, duplication, or disclosure by the Government is subject to restrictions as set forth in subparagraph (b)(3) of the Rights in Technical Data clause at DFARS 252.227-7013 (Nov. 1995) and of the Rights in Noncommercial Computer Software and Documentation clause at DFARS 252.227-7014 (Jun. 1995).

SMART Embedded Computing, Inc., dba Penguin Solutions

2900 S. Diablo Way, Suite 190

Tempe, Arizona 85282

USA

*For full legal terms and conditions, visit <https://www.penguinsolutions.com/edge/legal/>

Table of Contents

About this Manual	11
Safety Notes	19
Sicherheitshinweise	23
1 Hardware Preparation and Installation	27
1.1 Introduction	27
1.2 Ordering and Support Information	27
1.3 Getting Started	27
1.3.1 Overview of Startup Procedures	27
1.3.2 Unpacking Guidelines	28
1.4 Configuring Hardware	28
1.4.1 MVME3100 Layout	29
1.4.2 Configuration Switch (S4)	30
1.4.3 Geographical Address Switch (S3)	31
1.4.4 PMC I/O Voltage Configuration	32
1.4.5 RTM SEEPROM Address Switch (S1)	33
1.5 Installing Hardware	33
1.6 Connecting to Peripherals	34
1.7 Completing the Installation	36
2 Startup and Operation	37
2.1 Introduction	37
2.2 Applying Power	37
2.3 Before Applying Power	37
2.4 Switches and Indicators	37
3 MOTLoad Firmware	41
3.1 Introduction	41
3.2 Implementation and Memory Requirements	41
3.3 MOTLoad Commands	41
3.3.1 Utilities	41
3.3.2 Tests	42

Table of Contents

3.3.3	Command List	43
3.4	Using the Command Line Interface	48
3.4.1	Command Line Rules	49
3.4.2	Command Line Help	50
3.5	Firmware Settings	51
3.5.1	Default VME Settings	51
3.5.2	Control Register/Control Status Register Settings	54
3.5.3	Displaying VME Settings	54
3.5.4	Editing VME Settings	55
3.5.5	Deleting VME Settings	55
3.5.6	Restoring Default VME Settings	56
3.6	Remote Start	56
3.7	Alternate Boot Images and Safe Start	57
3.8	Firmware Startup Sequence Following Reset	57
3.9	Firmware Scan for Boot Image	58
3.10	Boot Images	59
3.10.1	Checksum Algorithm	60
3.10.2	Image Flags	60
3.10.3	User Images	61
3.10.4	Alternate Boot Data Structure	62
3.10.5	Alternate Boot Images and Safe Start	62
3.10.6	Boot Image Firmware Scan	63
3.11	Startup Sequence	64
4	Functional Description	65
4.1	Introduction	65
4.2	Features	65
4.3	Block Diagrams	68
4.4	Processor	69
4.5	System Memory	69
4.6	Local Bus Interface	69
4.6.1	Flash Memory	70
4.6.2	Control and Timers Logic	70
4.7	I2C Serial Interface and Devices	70
4.8	Ethernet Interfaces	71
4.9	Asynchronous Serial Ports	71
4.10	PCI/PCI-X Interfaces and Devices	72
4.10.1	MPC8540 PCI-X Interface	72

4.10.2	TSi148 VME Controller	72
4.10.3	Serial ATA Host Controller	72
4.10.4	PCI-X-to-PCI-X Bridges	73
4.10.5	PCI Mezzanine Card Slots	73
4.10.6	USB	74
4.10.7	PMC Expansion	75
4.11	General-Purpose Timers	75
4.12	Real-time Clock Battery	75
4.13	Reset Control Logic	75
4.14	Debug Support	76
5	Pin Assignments	77
5.1	Introduction	77
5.2	Connectors	77
5.2.1	PMC Expansion Connector (J4)	77
5.2.2	Ethernet Connectors (GENET1/J41B, GENET2/J2B, ENET1/J2A)	81
5.2.3	PCI Mezzanine Card (PMC) Connectors (J11 – J14, J21 – J23)	81
5.2.4	Serial Port Connectors (COM1/J41A, COM2–COM5/J2A-D)	92
5.2.5	VMEbus P1 Connector	92
5.2.6	VMEbus P2 Connector	94
5.2.7	MVME721 PMC I/O Module (PIM) Connectors (J10, J14)	96
5.2.8	Planar SATA Power Connector (J30)	97
5.2.9	USB Connector (J27)	98
5.2.10	SATA Connectors (J28 and J29)	98
5.3	Headers	99
5.3.1	Boundary Scan Header (J24)	99
5.3.2	Processor COP Header (J25)	99
6	Memory Maps	101
6.1	Introduction	101
6.2	Memory Maps	101
6.2.1	Default Processor Memory Map	101
6.2.2	MOTLoad's Processor Memory Map	102
6.2.3	VME Memory Map	102
6.2.4	System I/O Memory Map	103
6.2.5	System Status Register	105
6.2.6	System Control Register	106

Table of Contents

6.2.7	System Indicator Register	107
6.2.8	Flash Control/Status Register	108
6.2.9	PCI Bus Status Registers	109
6.2.10	Interrupt Detect Register	112
6.2.11	Presence Detect Register	113
6.2.12	PLD Revision Register	114
6.2.13	PLD Data Code Register	114
6.2.14	Test Register 1	115
6.2.15	Test Register 2	115
6.2.16	External Timer Registers	116
6.2.16.1	Prescalar Register	116
6.2.16.2	Control Registers	116
6.2.16.3	Compare Registers	118
6.2.16.4	Counter Registers	119
6.2.17	Geographical Address Register	119
7	Programming Details	121
7.1	Introduction	121
7.2	MPC8540 Reset Configuration	122
7.3	MPC8540 Interrupt Controller	128
7.4	Local Bus Controller Chip Select Assignments	129
7.5	Two-Wire Serial Interface	129
7.6	User Configuration EEPROM	130
7.7	VPD EEPROM	130
7.8	RTM VPD EEPROM	131
7.9	Ethernet PHY Address	131
7.10	Flash Memory	131
7.11	PCI IDSEL Definition	133
7.12	PCI Arbitration Assignments	134
7.13	Clock Distribution	135
7.14	MPC8540 Real-Time Clock Input	137
7.15	MPC8540 LBC Clock Divisor	137
8	Specifications	139
8.1	Power Requirements	139
8.2	Environmental Specifications	139
8.3	Thermally Significant Components	140

Table of Contents

9	Related Documentation	143
9.1	Penguin Solutions Documentation	143
9.2	Manufacturers' Documents	143
9.3	Related Specifications	145

Table of Contents

List of Figures

Figure 1-1	Board Layout	29
Figure 1-2	Geographical Address Switch Settings	31
Figure 2-1	Front Panel LEDs and Connectors	38
Figure 4-1	MVME3100 Block Diagram	68
Figure 4-2	MVME721 RTM Block Diagram	69
Figure 8-1	Primary Side Components	141
Figure 8-2	Secondary Side Components	142

List of Figures

List of Tables

Table 1-1	Startup Overview	28
Table 1-2	Configuration Switch (S4) Settings	30
Table 1-3	Geographical Address Switch Assignments	31
Table 1-4	Slot Geographical Address Settings	31
Table 1-5	RTM EEPROM Address Switch Assignments	33
Table 1-6	EEPROM Address Settings	33
Table 1-7	MVME3100 Connectors	35
Table 1-8	MVME721 Rear Transition Module Connectors	35
Table 2-1	Front-Panel LED Status Indicators	37
Table 2-2	MVME721 LED Status Indicators	39
Table 2-3	Additional On-board Status Indicators	39
Table 3-1	MOTLoad Commands	43
Table 4-1	MVME3100 Features Summary	65
Table 4-2	MVME721 RTM Features Summary	67
Table 5-1	PMC Expansion Connector Pin Assignment	78
Table 5-2	Ethernet Connectors Pin Assignment	81
Table 5-3	PMC Slot 1 Connector (J11) Pin Assignments	81
Table 5-4	PMC Slot 1 Connector (J12) Pin Assignments	83
Table 5-5	PMC Slot 1 Connector (J13) Pin Assignments	84
Table 5-6	PMC Slot 1 Connector (J14) Pin Assignments	86
Table 5-7	PMC Slot 2 Connector (J21) Pin Assignments	87
Table 5-8	PMC Slot 2 Connector (J22) Pin Assignments	89
Table 5-9	PMC Slot 2 Connector (J23) Pin Assignments	90
Table 5-10	COM Port Connector Pin Assignments	92
Table 5-11	VMEbus P1 Connector Pin Assignments	92
Table 5-12	VME P2 Connector Pinout	94
Table 5-13	MVME721 Host I/O Connector (J10) Pin Assignments	96
Table 5-14	Planar ATA Power Connector (J30) Pin Assignments	97
Table 5-15	USB Connector (J27) Pin Assignments	98
Table 5-16	SATA Connectors (J28 and J29) Pin Assignments	98
Table 5-17	Boundary Scan Header (J24) Pin Assignments	99
Table 5-18	Processor COP Header (J25) Pin Assignments	99
Table 6-1	Default Processor Address Map	101
Table 6-2	MOTLoad's Processor Address Map	102
Table 6-3	System I/O Memory Map	103
Table 6-4	System Status Register	105
Table 6-5	System Control Register	106

List of Tables

Table 6-6	System Indicator Register	107
Table 6-7	Flash Control/Status Register	108
Table 6-8	PCI Bus A Status Register	109
Table 6-9	PCI Bus B Status Register	110
Table 6-10	PCI Bus C Status Register	111
Table 6-11	Interrupt Detect Register	112
Table 6-12	Presence Detect Register	113
Table 6-13	PLD Revision Register	114
Table 6-14	PLD Data Code Register	114
Table 6-15	Test Register 1	115
Table 6-16	Test Register 2	115
Table 6-17	Prescalar Register	116
Table 6-18	Tick Timer Control Registers	116
Table 6-19	Tick Timer Compare Registers	119
Table 6-20	Tick Timer Counter Registers	119
Table 7-1	MPC8540 Power-on Reset Configuration Settings	122
Table 7-2	MPC8540 Interrupt Controller	128
Table 7-3	LBC Chip Select Assignments	129
Table 7-4	I2C Bus Device Addressing	129
Table 7-5	PHY Types and MII Management Bus Addresses	131
Table 7-6	Flash Options	132
Table 7-7	IDSEL and Interrupt Mapping for PCI Devices	133
Table 7-8	Planar PCI Device Identification	134
Table 7-9	PCI Arbitration Assignments	135
Table 7-10	Clock Assignments	136
Table 8-1	Current Requirements	139
Table 8-2	MVME3100 Specifications	139
Table 8-3	Thermally Significant Components	140
Table 9-1	Penguin Edge Documents	143
Table 9-2	Manufacturers' Documents	143
Table 9-3	Related Specifications	145

About this Manual

Overview of Contents

The *MVME3100 Single Board Computer Installation and Use* manual provides the information you will need to install and configure your MVME3100 single board computer and MVME721 rear transition module (RTM). It provides specific preparation and installation information, and data applicable to the board.

This manual is divided into the following chapters and appendices:

Safety Notes summarizes the safety instructions in the manual.

Sicherheitshinweise is a German translation of the Safety Notes chapter.

Chapter 1, Hardware Preparation and Installation, provides MVME3100 board preparation and installation instructions, as well as ESD precautionary notes.

Chapter 2, Startup and Operation, provides the power-up procedure and identifies the switches and indicators on the MVME3100.

Chapter 3, MOTLoad Firmware, describes the basic features of the MOTLoad firmware product.

Chapter 4, Functional Description, describes the MVME3100 and the MVME721 RTM on a block diagram level.

Chapter 5, Pin Assignments, provides pin assignments for various headers and connectors on the MVME3100 single board computer.

Chapter 6, Memory Maps, provides information on memory maps and system and configuration registers.

Chapter 7, Programming Details, provides additional programming information including IDSEL mapping, interrupt assignments for the MPC8540 interrupt controller, Flash memory, two-wire serial interface addressing, and other device and system considerations.

Appendix 8, Specifications, provides power requirements and environmental specifications.

Appendix 9, Related Documentation, provides a listing of related Penguin Solutions manuals, vendor documentation, and industry specifications.

Abbreviations

This document uses the following abbreviations:

Abbreviation	Description
AC	Alternating Current
ASIC	Application Specific Integrated Circuit
ATA	Advanced Technology Attachment
BLT	Block Transfer
CMC	Common Mezzanine Card
COM	Communication
COP	Common On-chip Processor
COTS	Commercial-Off-the-Shelf
CTS	Clear To Send
DDR	Double Data Rate
DIN	Deutsches Institut für Normung eV
DMA	Direct Memory Access
DPA	Downlink Packet Access
DUART	Dual Universal Asynchronous Receiver/Transmitter
ECC	Error Correction Code
ENET	Ethernet
ENV	Environment
ESD	Electrostatic Discharge
FAT	File Allocation Table
FEC	Fast Ethernet Controller
FIFO	First In First Out
FPU	Floating Point Unit
GA	Geographic Address
GENET	Gigabit Ethernet
GEV	Global Environment Variable



Abbreviation	Description
GMII	Gigabit Media Independent Interface
GPCM	General Purpose Chip select Machine
IBCA	Inter-Board Communication Address
IDE	Integrated Drive Electronics
IEEE	Institute of Electrical and Electronics Engineers
LBC	Local Bus Controller
MBLT	Multiplexed Block Transfer
MHz	Megahertz
MIIM	MII Management
MMU	Memory Management Unit
MPU	Memory Protection Unit Microprocessor Unit
MTBF	Mean Time Between Failure
NVRAM	Non Volatile RAM
PAL	Physical Abstraction Layer
PCB	Printed Circuit Board
PCI	Peripheral Connect Interface
PCI-X	Peripheral Component Interconnect -X
PHY	Physical Layer
PIC	Programmable Interrupt Controller
PIM	PCI Mezzanine Card Input/Output Module
PLD	Programmable Logic Device
PMC	PCI Mezzanine Card (IEEE P1386.1)
POST	Power On S Test
PrPMC	Processor PMC
QUART	Quad Universal Asynchronous Receiver/Transmitter
RTC	Real Time Clock

About this Manual





Abbreviation	Description
RTM	Rear Transition Module
RTOS	Real Time Operating System
SATA	Serial AT Attachment
SBC	Single Board Computer
SDRAM	Synchronous Dynamic Random Access Memory
SIG	Special Interest Group
SMT	Surface Mount Technology
SNR	receive data Poor SNR
SPD	Serial Presence Detect
TFTP	Trivial File Transfer Protocol
TSEC	Triple Speed Ethernet Controllers
TSOP	Thin Small Outline Package
UART	Universal Asynchronous Receiver/Transmitter
UNIX	UNIX operating system
VIO	Input/Output Voltage
VITA	VMEbus International Trade Association
VME	VersaModule Eurocard
VMEbus	VersaModule Eurocard bus
VPD	Vital Product Data
WP	Write Protect

Conventions

The following table describes the conventions used throughout this manual.

Notation	Description
0x00000000	Typical notation for hexadecimal numbers (digits are 0 through F), for example used for addresses and offsets
0b0000	Same for binary numbers (digits are 0 and 1)
bold	Used to emphasize a word
Screen	Used for on-screen output and code related elements or commands. Sample of Programming used in a table (9pt)
Courier + Bold	Used to characterize user input and to separate it from system output
<i>Reference</i>	Used for references and for table and figure descriptions
File > Exit	Notation for selecting a submenu
<text>	Notation for variables and keys
[text]	Notation for software buttons to click on the screen and parameter description
...	Repeated item for example node 1, node 2, ..., node 12
.	Omission of information from example/command that is not necessary at the time
..	Ranges, for example: 0..4 means one of the integers 0,1,2,3, and 4 (used in registers)
	Logical OR
	Indicates a hazardous situation which, if not avoided, could result in death or serious injury
	Indicates a hazardous situation which, if not avoided, may result in minor or moderate injury

About this Manual

Notation	Description
	Indicates a property damage message
	Indicates a hot surface that could result in moderate or serious injury
	Indicates an electrical situation that could result in moderate injury or death
<p>Use ESD protection</p> 	Indicates that when working in an ESD environment care should be taken to use proper ESD practices
	No danger encountered, pay attention to important information

Summary of Changes

This manual has been revised and replaces all prior editions.

Part Number	Publication Date	Description
6806800M28J	July 2022	Rebrand to Penguin Solutions.
6806800M28H	September 2019	Rebrand to SMART Embedded Computing
6806800M28G	May 2016	Removed <i>Declaration of Conformity</i> .
6806800M28F	August 2014	Updated Declaration of Conformity on page 31.
6806800M28E	May 2014	Rebrand to Artesyn template.
6806800M28D	November 2013	Updated and Serial ATA Host Controller on page 72 and Appendix 9, Related Documentation on page 143 .

Part Number	Publication Date	Description
6806800M28C	December 2012	Added <i>Declaration of Conformity</i> .
6806800M28B	August 2011	Updated <i>Safety Notes</i> and <i>Sicherheitshinweise</i> .
6806800M28A	April 2011	EA version.

Safety Notes

This section provides warnings that precede potentially dangerous procedures throughout this manual. Instructions contained in the warnings must be followed during all phases of operation, service, and repair of this equipment. You should also employ all other safety precautions necessary for the operation of the equipment in your operating environment. Failure to comply with these precautions or with specific warnings elsewhere in this manual could result in personal injury or damage to the equipment.

Penguin Solutions™ intends to provide all necessary information to install and handle the product in this manual. Because of the complexity of this product and its various uses, we do not guarantee that the given information is complete. If you need additional information, ask your Penguin Solutions representative.

This product is a Safety Extra Low Voltage (SELV) device designed to meet the EN60950-1 requirements for Information Technology Equipment. The use of the product in any other application may require safety evaluation specific to that application.

Only personnel trained by Penguin Solutions or persons qualified in electronics or electrical engineering are authorized to install, remove or maintain the product.

The information given in this manual is meant to complete the knowledge of a specialist and must not be used as replacement for qualified personnel.

Keep away from live circuits inside the equipment. Operating personnel must not remove equipment covers. Only factory authorized service personnel or other qualified service personnel may remove equipment covers for internal subassembly or component replacement or any internal adjustment.

Do not install substitute parts or perform any unauthorized modification of the equipment or the warranty may be voided. Contact your local Penguin Solutions representative for service and repair to make sure that all safety features are maintained.

EMC

The blade has been tested in a standard Penguin Edge™ system and found to comply with the limits for a Class A digital device in this system, pursuant to part 15 of the FCC Rules, EN 55022 Class A respectively. These limits are designed to provide reasonable protection against harmful interference when the system is operated in a commercial environment.

This is a Class A product based on the standard of the Voluntary Control Council for Interference by Information Technology Interference (VCCI). If this equipment is used in a domestic environment, radio disturbance may arise. When such trouble occurs, the user may be required to take corrective actions.

Safety Notes

The blade generates and uses radio frequency energy and, if not installed properly and used in accordance with this guide, may cause harmful interference to radio communications. Operating the system in a residential area is likely to cause harmful interference, in which case the user will be required to correct the interference at his own expense.

Installation

Damage of Circuits

Electrostatic discharge and incorrect blade installation and removal can damage circuits or shorten their life.

Before touching the blade or electronic components, make sure that you are working in an ESD-safe environment.

Damage of the Product and Additional Devices and Modules

Incorrect installation or removal of additional devices or modules damages the product or the additional devices or modules.

Before installing or removing additional devices or modules, read the respective documentation and use appropriate tools.

Configuration Switches/Jumpers

Product Malfunction

Switches marked as Reserved might carry production-related functions and can cause the product to malfunction if their setting is changed.

Do not change settings of switches marked as reserved.

Operation

Product Damage

High humidity and condensation on surfaces cause short circuits.

Do not operate the product outside the specified environmental limits. Make sure the product is completely dry and there is no moisture on any surface before applying power.

Environment

Environmental Damage

Improperly disposing of used products may harm the environment. Always dispose of used products according to your country's legislation and manufacturer's instructions.

Safety Notes

Sicherheitshinweise

Dieses Kapitel enthält Hinweise, die potentiell gefährlichen Prozeduren innerhalb dieses Handbuchs vorrangestellt sind. Beachten Sie unbedingt in allen Phasen des Betriebs, der Wartung und der Reparatur des Systems die Anweisungen, die diesen Hinweisen enthalten sind. Sie sollten außerdem alle anderen Vorsichtsmaßnahmen treffen, die für den Betrieb des Produktes innerhalb Ihrer Betriebsumgebung notwendig sind. Wenn Sie diese Vorsichtsmaßnahmen oder Sicherheitshinweise, die an anderer Stelle dieses Handbuchs enthalten sind, nicht beachten, kann das Verletzungen oder Schäden am Produkt zur Folge haben.

Penguin Solutions™ ist darauf bedacht, alle notwendigen Informationen zum Einbau und zum Umgang mit dem Produkt in diesem Handbuch bereit zu stellen. Da es sich jedoch um ein komplexes Produkt mit vielfältigen Einsatzmöglichkeiten handelt, können wir die Vollständigkeit der im Handbuch enthaltenen Informationen nicht garantieren. Falls Sie weitere Informationen benötigen sollten, wenden Sie sich bitte an die für Sie zuständige Geschäftsstelle von Penguin Solutions.

Das Produkt wurde entwickelt, um die Sicherheitsanforderungen für SELV Geräte nach der Norm EN 60950-1 für informationstechnische Einrichtungen zu erfüllen. Die Verwendung des Produkts in einer anderen Anwendung erfordert eine Sicherheitsüberprüfung für diese spezifische Anwendung.

Einbau, Wartung und Betrieb dürfen nur von durch Penguin Solutions ausgebildetem oder im Bereich Elektronik oder Elektrotechnik qualifiziertem Personal durchgeführt werden. Die in diesem Handbuch enthaltenen Informationen dienen ausschließlich dazu, das Wissen von Fachpersonal zu ergänzen, können dieses jedoch nicht ersetzen.

Halten Sie sich von stromführenden Leitungen innerhalb des Produktes fern. Entfernen Sie auf keinen Fall Abdeckungen am Produkt. Nur werksseitig zugelassenes Wartungspersonal oder anderweitig qualifiziertes Wartungspersonal darf Abdeckungen entfernen, um Komponenten zu ersetzen oder andere Anpassungen vorzunehmen.

Installieren Sie keine Ersatzteile oder führen Sie keine unerlaubten Veränderungen am Produkt durch, sonst verfällt die Garantie. Wenden Sie sich für Wartung oder Reparatur bitte an die für Sie zuständige Geschäftsstelle von Penguin Solutions. So stellen Sie sicher, dass alle sicherheitsrelevanten Aspekte beachtet werden.

EMV

Das Blade wurde in einem Penguin Edge™ Standardsystem getestet. Es erfüllt die für digitale Geräte der Klasse A gültigen Grenzwerte in einem solchen System gemäß den FCC-Richtlinien Abschnitt 15 bzw. EN 55022 Klasse A. Diese Grenzwerte sollen einen angemessenen Schutz vor Störstrahlung beim Betrieb des Blades in Gewerbe- sowie Industriegebieten gewährleisten.

Sicherheitshinweise

Das Blade arbeitet im Hochfrequenzbereich und erzeugt Störstrahlung. Bei unsachgemäßem Einbau und anderem als in diesem Handbuch beschriebenen Betrieb können Störungen im Hochfrequenzbereich auftreten.

Warnung! Dies ist eine Einrichtung der Klasse A. Diese Einrichtung kann im Wohnbereich Funkstörungen verursachen. In diesem Fall kann vom Betreiber verlangt werden, angemessene Maßnahmen durchzuführen.

Installation

Beschädigung von Schaltkreisen

Elektrostatische Entladung und unsachgemäßer Ein- und Ausbau von Blades kann Schaltkreise beschädigen oder ihre Lebensdauer verkürzen.

Bevor Sie Blades oder elektronische Komponenten berühren, vergewissern Sie sich, daß Sie in einem ESD-geschützten Bereich arbeiten.

Beschädigung des Produktes und der Zusatzmodule

Fehlerhafter Ein- oder Ausbau von Zusatzmodulen führt zu Beschädigung des Produktes oder der Zusatzmodule.

Lesen Sie deshalb vor dem Ein- oder Ausbau von Zusatzmodulen die Dokumentation und benutzen Sie angemessenes Werkzeug.

Schaltereinstellungen

Fehlfunktion des Produktes

Schalter, die mit 'Reserved' gekennzeichnet sind, können mit produktionsrelevanten Funktionen belegt sein. Das Ändern dieser Schalter kann im normalen Betrieb Störungen auslösen.

Verstellen Sie nur solche Schalter, die nicht mit 'Reserved' gekennzeichnet sind.

Betrieb

Beschädigung des Blades

Hohe Luftfeuchtigkeit und Kondensat auf der Oberfläche des Blades können zu Kurzschlüssen führen.

Betreiben Sie das Blade nur innerhalb der angegebenen Grenzwerte für die relative Luftfeuchtigkeit und Temperatur. Stellen Sie vor dem Einschalten des Stroms sicher, dass sich auf dem Blade kein Kondensat befindet.

Umweltschutz

Umweltverschmutzung

Falsche Entsorgung der Produkte schadet der Umwelt. Entsorgen Sie alte Produkte gemäß der in Ihrem Land gültigen Gesetzgebung und den Empfehlungen des Herstellers.

Hardware Preparation and Installation

1.1 Introduction

The MVME3100 is a single-slot, single board computer based on the MPC8540 PowerQUICC III™ integrated processor. The MVME3100 provides serial ATA (SATA), USB 2.0, 2eSST VMEbus interfaces, dual 64-bit/100MHz PMC sites, up to 128MB of flash, dual 10/100/1000 Ethernet, one 10/100 Ethernet, and five serial ports. This board supports front and rear I/O and a single SODIMM module for DDR memory. Access to rear I/O is available with the MVME721 rear transition module (RTM).

Front-panel connectors on the MVME3100 board include: one RJ-45 connector for the Gigabit Ethernet, one RJ-45 connector for the asynchronous serial port, one USB port with one type A connector, one SATA port with one external SATA connector, and a combined reset and abort switch.

Rear-panel connectors on the MVME721 board include: one RJ-45 connector for each of the 10/100 and 10/100/1000 BaseT Ethernets and four RJ-45 connectors for the asynchronous serial ports. The RTM also provides two planar connectors for one PIM with rear I/O.

1.2 Ordering and Support Information

Refer to the data sheets for the MVME3100 SBC for a complete list of available variants and accessories. Refer to [Appendix 9, Related Documentation on page 143](#) or consult your local Penguin Solutions™ sales representative for the availability of other variants.

For technical assistance, documentation, or to report product damage or shortages, contact your local Penguin Solutions sales representative or visit <https://www.penguinsolutions.com/edge/support/>.

1.3 Getting Started

This section provides an overview of the steps necessary to install and power up the MVME3100 and a brief section on unpacking and ESD precautions.

1.3.1 Overview of Startup Procedures

The following table lists the things you need to do before you can use this board and tells where to find the information you need to perform each step. Be sure to read this entire chapter, including all Caution and Warning notes, before you begin.

Hardware Preparation and Installation

Table 1-1 Startup Overview

What you need to do...	Refer to...
Unpack the hardware.	Unpacking Guidelines on page 28
Identify various components on the board.	MVME3100 Layout on page 29
Install the MVME3100 board in a chassis.	Installing Hardware on page 33
Connect any other equipment you will use.	Connecting to Peripherals on page 34
Verify the hardware is installed.	Completing the Installation on page 36

1.3.2 Unpacking Guidelines

Unpack the equipment from the shipping carton. Refer to the packing list and verify that all items are present. Save the packing material for storing and reshipping of equipment.

If the shipping carton is damaged upon receipt, request that the carrier's agent be present during the unpacking and inspection of the equipment.

<p>Use ESD protection</p> 	<p>Damage of Circuits</p> <p>Electrostatic discharge and incorrect installation and removal of the product can damage circuits or shorten their life.</p> <p>Before touching the product make sure that you are working in an ESD-safe environment or wear an ESD wrist strap or ESD shoes. Hold the product by its edges and do not touch any components or circuits.</p>
---	---

1.4 Configuring Hardware

This section discusses certain hardware and software tasks that may need to be performed prior to installing the board in a chassis.

To produce the desired configuration and ensure proper operation of the MVME3100, you may need to carry out certain hardware modifications before installing the module.

Most options on the MVME3100 are software configurable. Configuration changes are made by setting bits in control registers after the board is installed in a system.

Jumpers/switches are used to control those options that are not software configurable. These jumper settings are described further on in this section. If you are resetting the board jumpers from their default settings, it is important to verify that all settings are reset properly.

1.4.1 MVME3100 Layout

Figure 1-1 on page 29 illustrates the placement of the jumpers, headers, connectors, switches, and various other components on the MVME3100.

There are two switch blocks which have user-selectable settings. Refer to *Table 1-2*, *Table 1-3*, and *Table 1-4* for switch settings. There is one switch on the MVME721. Refer to *Table 1-5* and *Table 1-6* for switch settings.

The MVME3100 is factory tested and shipped with the configuration described in the following sections.

Figure 1-1 Board Layout

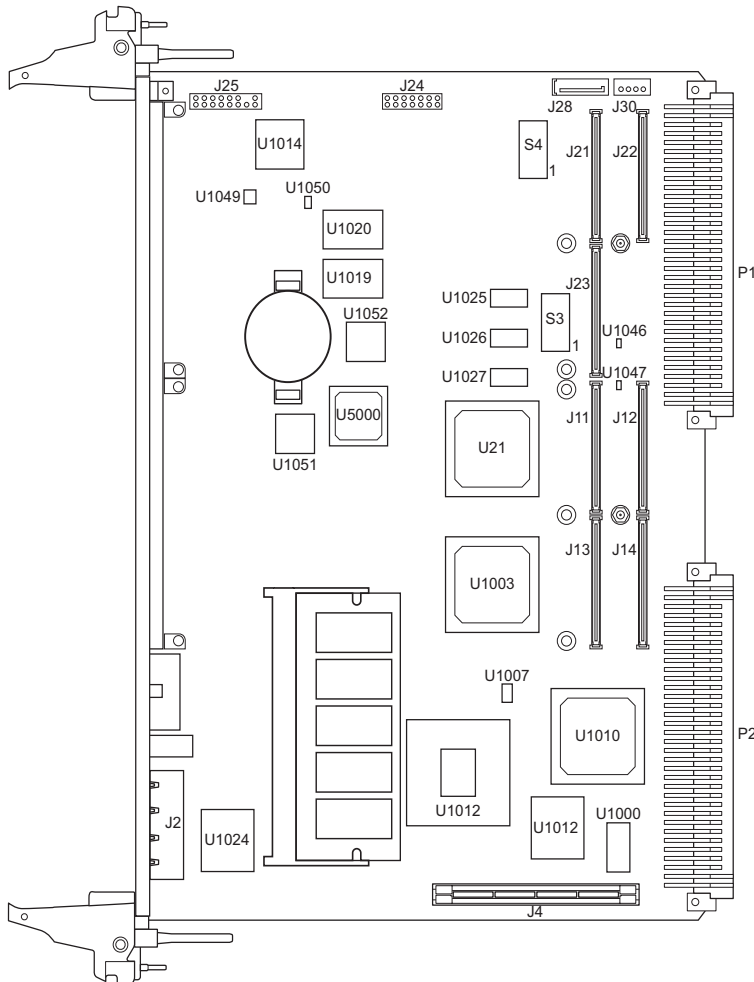

Hardware Preparation and Installation

1.4.2 Configuration Switch (S4)

An 8-position SMT configuration switch controls the VME SCON setting, flash bank write-protect, and the safe start ENV settings. It also selects the flash boot image. The default setting on all switch positions is OFF.

Table 1-2 Configuration Switch (S4) Settings

Switch	Pos.	Setting		Notes
		OFF (Factory Default)	ON	
SAFE_START	1	Normal ENV settings should be used.	Safe ENV settings should be used.	This switch status is readable from System Status register 1, bit 5. Software may check this bit and act accordingly.
BOOT BLOCK SELECT	2	Flash memory map is normal and boot block A is selected.	Boot block B is selected and mapped to the highest address.	
FLASH BANK WP	3	Entire flash is not write-protected.	Flash is write-protected.	
Reserved	4			
VME SCON AUTO/MANUAL MODE	5	Auto-SCON mode.	Manual SCON mode.	Manual SCON mode works in conjunction with the VME SCON SELECT switch.
MANUAL VME SCON SELECT	6	Non-SCON mode.	Always SCON mode.	This switch is only effective when the VME SCON AUTO/MANUAL MODE switch is ON.
Reserved	7			
TRST SELECT	8	Normal MPC8540 TRST mode where the board HRESET will assert TRST.	Isolates the board HRESET from TRST and allows the board to reset without resetting the MPC8540 JTAG/COP interface.	This switch should remain in the OFF position unless a MPC8540 emulator is attached.

1.4.3 Geographical Address Switch (S3)

The TSi148 VMEbus Status register provides the VMEbus geographical address of the MVME3100. This switch reflects the inverted states of the geographical address signals. Applications not using the 5-row backplane can use the geographical address switch to assign a geographical address.

Figure 1-2 Geographical Address Switch Settings

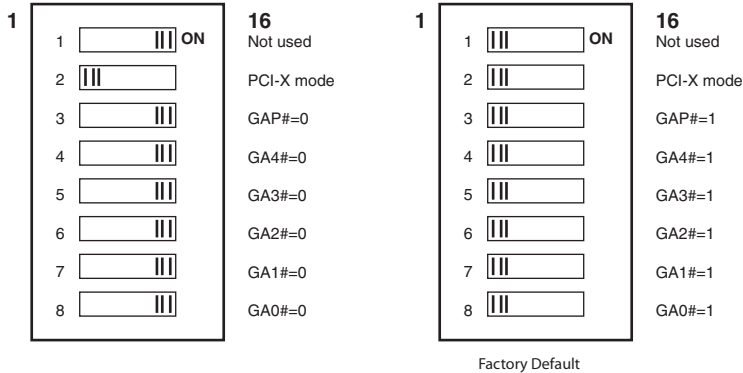

Table 1-3 Geographical Address Switch Assignments

Position	SW1	SW2 ¹	SW3	SW4	SW5	SW6	SW7	SW8
Function	Not Used	PCI Bus A mode	GAP	GA4	GA3	GA2	GA1	GA0
Factory Setting (Default)	OFF	OFF PCI mode	OFF 1	OFF 1	OFF 1	OFF 1	OFF 1	OFF 1

¹SW2 has been configured to work in PCI-X mode only. The default setting is OFF.

Table 1-4 Slot Geographical Address Settings

Slot Address	GAP GA(4:0)	SW3	SW4	SW5	SW6	SW7	SW8
1	1 11110	OFF	OFF	OFF	OFF	OFF	ON
2	1 11101	OFF	OFF	OFF	OFF	ON	OFF
3	0 11100	ON	OFF	OFF	OFF	ON	ON
4	1 11011	OFF	OFF	OFF	ON	OFF	OFF

Hardware Preparation and Installation

Table 1-4 Slot Geographical Address Settings (continued)

Slot Address	GAP GA(4:0)	SW3	SW4	SW5	SW6	SW7	SW8
5	0 11010	ON	OFF	OFF	ON	OFF	ON
6	0 11001	ON	OFF	OFF	ON	ON	OFF
7	1 11000	OFF	OFF	OFF	ON	ON	ON
8	1 10111	OFF	OFF	ON	OFF	OFF	OFF
9	0 10110	ON	OFF	ON	OFF	OFF	ON
10	0 10101	ON	OFF	ON	OFF	ON	OFF
11	1 10100	OFF	OFF	ON	OFF	ON	ON
12	0 10011	ON	OFF	ON	ON	OFF	OFF
13	1 10010	OFF	OFF	ON	ON	OFF	ON
14	1 10001	OFF	OFF	ON	ON	ON	OFF
15	0 10000	ON	OFF	ON	ON	ON	ON
16	1 01111	OFF	ON	OFF	OFF	OFF	OFF
17	0 01110	ON	ON	OFF	OFF	OFF	ON
18	0 01101	ON	ON	OFF	OFF	ON	OFF
19	1 01100	OFF	ON	OFF	OFF	ON	ON
20	0 01011	ON	ON	OFF	ON	OFF	OFF
21	1 01010	OFF	ON	OFF	ON	OFF	ON

1.4.4 PMC I/O Voltage Configuration

The on-board PMC sites may be configured to support 3.3V or 5.0V I/O PMC modules. To support 3.3V or 5.0V I/O PMC modules, both PMC I/O keying pins must be installed in the holes. If both keying pins are not in the same location or if the keying pins are not installed, the PMC sites will not function. Note that setting the PMC I/O voltage to 5.0V forces the PMC sites to operate in PCI mode instead of PCI-X mode. The default factory configuration is for 3.3V PMC I/O voltage.

1.4.5 RTM EEPROM Address Switch (S1)

A 4-position SMT configuration switch is located on the RTM to set the device address of the RTM serial EEPROM device. The switch settings are defined in the following table.

Table 1-5 RTM EEPROM Address Switch Assignments

Position	SW1	SW2	SW3	SW4
Function	A0	A1	A2	Not Used
OFF	1	1	1	

Table 1-6 EEPROM Address Settings

Device Address	A(2:0)	SW1	SW2	SW3
\$A0	000	ON	ON	ON
\$A2	001	OFF	ON	ON
\$A4	010	ON	OFF	ON
\$A6	011	OFF	OFF	ON
\$A8	100	ON	ON	OFF
\$AA (Factory)	101	OFF	ON	OFF
\$AC	110	ON	OFF	OFF
\$AE	111	OFF	OFF	OFF

The RTM EEPROM address switches must be set for address \$AA in order for this device to be accessible by MOTLoad.

1.5 Installing Hardware



Damage of the Product and Additional Devices and Modules

Incorrect installation or removal of additional devices or modules may damage the product or the additional devices or modules.

Before installing or removing additional devices or modules, read the respective documentation.

Hardware Preparation and Installation

Use ESD
protection



Damage of Circuits

Electrostatic discharge and incorrect installation and removal of the product can damage circuits or shorten their life.

Before touching the product make sure that you are working in an ESD-safe environment or wear an ESD wrist strap or ESD shoes. Hold the product by its edges and do not touch any components or circuits.



Product Malfunction

Switches marked as Reserved might carry production-related functions and can cause the product to malfunction if their setting is changed.

Do not change settings of switches marked as reserved.

Procedure

Use the following steps to install the MVME3100 into your computer chassis.

1. Attach an ESD strap to your wrist. Attach the other end of the ESD strap to an electrical ground (refer to [Unpacking Guidelines](#)). The ESD strap must be secured to your wrist and to ground throughout the procedure.
2. Remove any filler panel that might fill that slot.
3. Install the top and bottom edge of the MVME3100 into the guides of the chassis.
4. Ensure that the levers of the two injector/ejectors are in the outward position.
5. Slide the MVME3100 into the chassis until resistance is felt.
6. Simultaneously move the injector/ejector levers in an inward direction.
7. Verify that the MVME3100 is properly seated and secure it to the chassis using the two screws located adjacent to the injector/ejector levers.
8. Connect the appropriate cables to the MVME3100.
9. To remove the board from the chassis, press the red locking tabs (IEEE handles only) and reverse the procedure.

1.6 Connecting to Peripherals

When the MVME3100 is installed in a chassis, you are ready to connect peripherals and apply power to the board.

Figure 1-1 shows the locations of the various connectors while *Table 1-7* and *Table 1-8* list them for you. Refer to *Chapter 5, Pin Assignments* for the pin assignments of the connectors listed below



Damage of the Product and Additional Devices and Modules

Incorrect installation or removal of additional devices or modules damages the product or the additional devices or modules.

Before installing or removing additional devices or modules, read the respective documentation and use appropriate tools.

Table 1-7 MVME3100 Connectors

Connector	Function
J4	PMC expansion connector
J11, J12, J13, J14	PCI mezzanine card (PMC) slot 1 connector
J21, J22, J23	PCI mezzanine card (PMC) slot 2 connector
J24	Boundary scan header
J25	COP header
J27	USB connector
J28	Front panel SATA connector
J29	Planar SATA connector
J30	Planar SATA power connector
J41B	10/100/1000Mb/s Ethernet connector
J41A	COM port connector
P1, P2	VME backplane connectors

Table 1-8 MVME721 Rear Transition Module Connectors

Connector	Function
J1A, J1B, J1C, J1D	COM port connectors
J2A	10/100/1000Mb/s Ethernet connector
J2B	10/100Mb/s Ethernet connector

Hardware Preparation and Installation

Table 1-8 MVME721 Rear Transition Module Connectors (continued)

Connector	Function
J10	PIM power/ground
J14	PIM I/O
P2	VME backplane connector

1.7 Completing the Installation

Verify that hardware is installed and the power/peripheral cables connected are appropriate for your system configuration.

Replace the chassis or system cover, reconnect the system to the AC or DC power source, and turn the equipment power on.

Startup and Operation

2.1 Introduction

This chapter gives you information about the power-up procedure and runtime switches and indicators.

2.2 Applying Power

After you verify that all necessary hardware preparation is complete and all connections are made correctly, you can apply power to the system.

2.3 Before Applying Power

Verify that the chassis power supply voltage setting matches the voltage present in the country of use (if the power supply in your system is not auto-sensing)

On powering up, the MVME3100 brings up the MOTLoad prompt, `MVME3100>`

2.4 Switches and Indicators

The MVME3100 board provides a single push button switch that provides both abort and reset (ABT/RST) functions. When the switch is pressed for less than five seconds, an abort interrupt is generated to the processor. If the switch is held for more than five seconds, a board hard reset is generated. The board hard reset will reset the MPC8540, local PCI/PCI-X buses, Ethernet PHYs, serial ports, Flash devices, and PLD(s). If the MVME3100 is configured as the VME system controller, the VME bus and local TSi148 reset input are also reset.

The MVME3100 has four front-panel indicators. The following table describes these indicators:

Table 2-1 Front-Panel LED Status Indicators

Function	Label	Color	Description
Board Fail	FAIL	Yellow	Board has a failure. After Power On or reset, this LED is ON until extinguished by firmware or software.
User Defined	USER 1	Green	This indicator is illuminated by software assertion of its corresponding register bit.

Startup and Operation

Table 2-1 Front-Panel LED Status Indicators (continued)

Function	Label	Color	Description
GENET 1 Link / Speed	SPEED	Off	No link
		Yellow	10/100Base-T operation
		Green	1000Base-T operation
GENET 1 Activity	ACT	Blinking Green	Activity proportional to bandwidth utilization.
		Off	No activity

Figure 2-1 Front Panel LEDs and Connectors

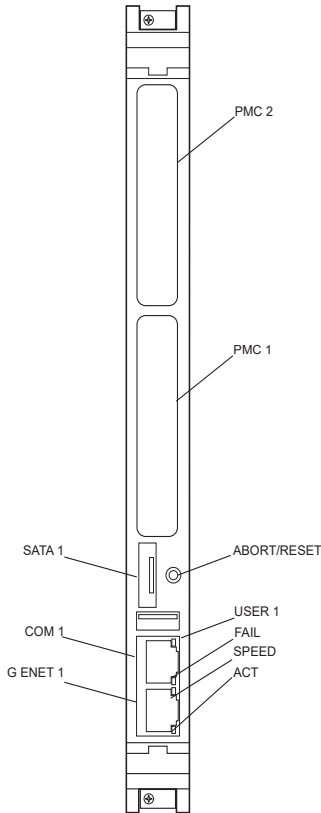

The MVME721 rear transition module also has four status indicators. The following table describes these indicators:

Table 2-2 MVME721 LED Status Indicators

Function	Label	Color	Description
GENET 2 Link/Speed	SPEED	Off	No link
		Yellow	10/100Base-T operation
		Green	1000Base-T operation
GENET 2 Activity	ACT	Blinking Green	Activity proportional to bandwidth utilization.
		Off	No activity
ENET 1 Link/Speed	SPEED	Off	No link
		Yellow	10/100Base-T operation
ENET 1 Activity	ACT	Blinking Green	Activity proportional to bandwidth utilization.
		Off	No activity

Table 2-3 Additional On-board Status Indicators

Function	Label	Color	Description
User Defined LED 2	DS7 (silkscreen)	Green	This indicator is illuminated by software assertion of its corresponding register bit.
User Defined LED 3	DS8 (silkscreen)	Green	This indicator is illuminated by software assertion of its corresponding register bit.
Power Supply Fail	DS1 (silkscreen)	Red	This indicator is illuminated to indicate a power supply fail condition.
SATA 0 Activity	DS4 (silkscreen)	Green	SATA 0 activity indicator
SATA 1 Activity	DS5 (silkscreen)	Green	SATA 1 activity indicator

Startup and Operation

Table 2-3 Additional On-board Status Indicators (continued)

Function	Label	Color	Description
MPC8540 Ready	DS3 (silkscreen)	Green	Indicates that the MPC8540 has completed the reset operation and is not in a power-down state. The MPC8540 Ready is multiplexed with the MPC8540 TRIG_OUT so the LED can be programmed to indicate one of three trigger events based on the value in the MPC8540 TOSR register.
GENET 1 Link Quality	DS2 (silkscreen)	Off Slow Blink Green Fast Blink Green Green	Extremely poor Signal to Noise ratio - cannot receive data Poor SNR - receive errors detected Fair SNR - close to data error threshold Good SNR on link
GENET 2 Link Quality	DS3	[Same as DS2}	

MOTLoad Firmware

3.1 Introduction

The MOTLoad firmware package serves as a board power-up and initialization package, as well as a vehicle from which user applications can be booted. A secondary function of the MOTLoad firmware is to serve in some respects as a test suite providing individual tests for certain devices. This chapter includes a list of standard MOTLoad commands, the default VME and firmware settings that are changeable by the user, remote start, and the alternate boot procedure.

MOTLoad is controlled through an easy-to-use, UNIX-like, command line interface. The MOTLoad software package is similar to many end-user applications designed for the embedded market, such as the real time operating systems currently available.

Refer to the *MOTLoad Firmware Package User's Manual*, listed in [Appendix 9, Related Documentation](#) for more details.

3.2 Implementation and Memory Requirements

The implementation of MOTLoad and its memory requirements are product specific. The MVME3100 Single Board Computer (SBC) is offered with a wide range of memory (for example, DRAM, external cache, flash). Typically, the smallest amount of on-board DRAM that an Penguin Edge SBC has is 32MB. Each supported product line has its own unique MOTLoad binary image(s). Currently the largest MOTLoad compressed image is less than 1MB in size.

3.3 MOTLoad Commands

MOTLoad supports two types of commands (applications): utilities and tests. Both types of commands are invoked from the MOTLoad command line in a similar fashion. Beyond that, MOTLoad utilities and MOTLoad tests are distinctly different.

3.3.1 Utilities

The definition of a MOTLoad utility application is very broad. Simply stated, it is considered a MOTLoad command, if it is not a MOTLoad test. Typically, MOTLoad utility applications are applications that aid the user in some way (that is, they do something useful). From the perspective of MOTLoad, examples of utility applications are: configuration, data/status displays, data manipulation, help routines, data/status monitors, etc.

MOTLoad Firmware

Operationally, MOTLoad utility applications differ from MOTLoad test applications in several ways:

- Only one utility application operates at any given time (that is, multiple utility applications cannot be executing concurrently)
- Utility applications may interact with the user. Most test applications do not.

3.3.2 Tests

A MOTLoad test application determines whether or not the hardware meets a given standard. Test applications are validation tests. Validation is conformance to a specification. Most MOTLoad tests are designed to directly validate the functionality of a specific SBC subsystem or component. These tests validate the operation of such SBC modules as: dynamic memory, external cache, NVRAM, real time clock, etc.

All MOTLoad tests are designed to validate functionality with minimum user interaction. Once launched, most MOTLoad tests operate automatically without any user interaction. There are a few tests where the functionality being validated requires user interaction (that is, switch tests, interactive plug-in hardware modules, etc.). Most MOTLoad test results (error-data/status-data) are logged, not printed. All MOTLoad tests/commands have complete and separate descriptions (refer to the *MOTLoad Firmware Package User's Manual* for this information).

All devices that are available to MOTLoad for validation/verification testing are represented by a unique device path string. Most MOTLoad tests require the operator to specify a test device at the MOTLoad command line when invoking the test.

A listing of all device path strings can be displayed through the `devShow` command. If an SBC device does not have a device path string, it is not supported by MOTLoad and can not be directly tested. There are a few exceptions to the device path string requirement, like testing RAM, which is not considered a true device and can be directly tested without a device path string. Refer to the `devShow` command description page in the *MOTLoad Firmware Package User's Manual*.

Most MOTLoad tests can be organized to execute as a group of related tests (a testSuite) through the use of the `testSuite` command. The expert operator can customize their testing by defining and creating a custom testSuite(s). The list of built-in and user-defined MOTLoad testSuites, and their test contents, can be obtained by entering `testSuite -d` at the MOTLoad prompt. All testSuites that are included as part of a product specific MOTLoad firmware package are product specific. For more information, refer to the `testSuite` command description page in the MOTLoad Firmware Package User's Manual.

Test results and test status are obtained through the `testStatus`, `errorDisplay`, and `taskActive` commands. Refer to the appropriate command description page in the *MOTLoad Firmware Package User's Manual* for more information.

3.3.3 Command List

The following table provides a list of all current MOTLoad commands. Products supported by MOTLoad may or may not employ the full command set. Typing `help` at the MOTLoad command prompt will display all commands supported by MOTLoad for a given product.

Table 3-1 MOTLoad Commands

Command	Description
as	One-Line Instruction Assembler
bcb bch bcw	Block Compare Byte/Halfword/Word
bdTempShow	Display Current Board Temperature
bfb bfh bfw	Block Fill Byte/Halfword/Word
blkCp	Block Copy
blkFmt	Block Format
blkRd	Block Read
blkShow	Block Show Device Configuration Data
blkVe	Block Verify
blkWr	Block Write
bmb bmh bmw	Block Move Byte/Halfword/Word
br	Assign/Delete/Display User-Program Break-Points
bsb bsh bsw	Block Search Byte/Halfword/Word
bvb bvh bvw	Block Verify Byte/Halfword/Word

MOTLoad Firmware

Table 3-1 MOTLoad Commands (continued)

Command	Description
cdDir	ISO9660 File System Directory Listing
cdGet	ISO9660 File System File Load
clear	Clear the Specified Status/History Table(s)
cm	Turns on Concurrent Mode
csb csh csw	Calculates a Checksum Specified by Command-line Options
devShow	Display (Show) Device/Node Table
diskBoot	Disk Boot (Direct-Access Mass-Storage Device)
downLoad	Down Load S-Record from Host
ds	One-Line Instruction Disassembler
echo	Echo a Line of Text
elfLoader	ELF Object File Loader
errorDisplay	Display the Contents of the Test Error Status Table
eval	Evaluate Expression
execProgram	Execute Program
fatDir	FAT File System Directory Listing
fatGet	FAT File System File Load
fdShow	Display (Show) File Descriptor
flashLock	Flash Memory Sector Lock
flashProgram	Flash Memory Program
flashShow	Display Flash Memory Device Configuration Data
flashUnlock	Flash Memory Sector Unlock
gd	Go Execute User-Program Direct (Ignore Break-Points)

Table 3-1 MOTLoad Commands (continued)

Command	Description
gevDelete	Global Environment Variable Delete
gevDump	Global Environment Variable(s) Dump (NVRAM Header + Data)
gevEdit	Global Environment Variable Edit
gevInit	Global Environment Variable Area Initialize (NVRAM Header)
gevList	Global Environment Variable Labels (Names) Listing
gevShow	Global Environment Variable Show
gn	Go Execute User-Program to Next Instruction
go	Go Execute User-Program
gt	Go Execute User-Program to Temporary Break-Point
hbd	Display History Buffer
hbx	Execute History Buffer Entry
help	Display Command/Test Help Strings
l2CacheShow	Display state of L2 Cache and L2CR register contents
l3CacheShow	Display state of L3 Cache and L3CR register contents
mdb mdh mdw	Memory Display Bytes/Halfwords/Words
memShow	Display Memory Allocation
mmb mmh mmw	Memory Modify Bytes/Halfwords/Words
mpuFork	Execute program from idle processor
mpuShow	Display multi-processor control structure
mpuStart	Start the other MPU
netBoot	Network Boot (BOOT/TFTP)

MOTLoad Firmware

Table 3-1 MOTLoad Commands (continued)

Command	Description
netShow	Display Network Interface Configuration Data
netShut	Disable (Shutdown) Network Interface
netStats	Display Network Interface Statistics Data
noCm	Turns off Concurrent Mode
pciDataRd	Read PCI Device Configuration Header Register
pciDataWr	Write PCI Device Configuration Header Register
pciDump	Dump PCI Device Configuration Header Register
pciShow	Display PCI Device Configuration Header Register
pciSpace	Display PCI Device Address Space Allocation
ping	Ping Network Host
portSet	Port Set
portShow	Display Port Device Configuration Data
rd	User Program Register Display
reset	Reset System
rs	User Program Register Set
set	Set Date and Time
sromRead	SROM Read
sromWrite	SROM Write
sta	Symbol Table Attach
stl	Symbol Table Lookup
stop	Stop Date and Time (Power-Save Mode)
taskActive	Display the Contents of the Active Task Table
tc	Trace (Single-Step) User Program
td	Trace (Single-Step) User Program to Address

Table 3-1 MOTLoad Commands (continued)

Command	Description
testDisk	Test Disk
testEnetPtP	Ethernet Point-to-Point
testNvramRd	NVRAM Read
testNvramRdWr	NVRAM Read/Write (Destructive)
testRam	RAM Test (Directory)
testRamAddr	RAM Addressing
testRamAlt	RAM Alternating
testRamBitToggle	RAM Bit Toggle
testRamBounce	RAM Bounce
testRamCodeCopy	RAM Code Copy and Execute
testRamEccMonitor	Monitor for ECC Errors
testRamMarch	RAM March
testRamPatterns	RAM Patterns
testRamPerm	RAM Permutations
testRamQuick	RAM Quick
testRamRandom	RAM Random Data Patterns
testRtcAlarm	RTC Alarm
testRtcReset	RTC Reset
testRtcRollOver	RTC Rollover
testRtcTick	RTC Tick
testSerialExtLoop	Serial External Loopback
testSerialIntLoop	Serial Internal Loopback
testStatus	Display the Contents of the Test Status Table

MOTLoad Firmware

Table 3-1 MOTLoad Commands (continued)

Command	Description
testSuite	Execute Test Suite
testSuiteMake	Make (Create) Test Suite
testWatchdogTimer	Tests the Accuracy of the Watchdog Timer Device
tftpGet	TFTP Get
tftpPut	TFTP Put
time	Display Date and Time
transparentMode	Transparent Mode (Connect to Host)
tsShow	Display Task Status
upLoad	Up Load Binary Data from Target
version	Display Version String(s)
vmeCfg	Manages user specified VME configuration parameters
vpdDisplay	VPD Display
vpdEdit	VPD Edit
wait	Wait for Test Completion
waitProbe	Wait for I/O Probe to Complete

3.4 Using the Command Line Interface

Interaction with MOTLoad is performed via a command line interface through a serial port on the SBC, which is connected to a terminal or terminal emulator (for example, Window's Hypercomm). The default MOTLoad serial port settings are: 9600 baud, 8 bits, no parity.

The MOTLoad command line interface is similar to a UNIX command line shell interface. Commands are initiated by entering a valid MOTLoad command (a text string) at the MOTLoad command line prompt and pressing the carriage-return key to signify the end of input. MOTLoad then performs the specified action. An example of a MOTLoad command line prompt is shown below. The MOTLoad prompt changes according to what product it is used on (for example, MVME5500, MVME6100, MVME3100).

Example:

```
MVME3100>
```

If an invalid MOTLoad command is entered at the MOTLoad command line prompt, MOTLoad displays a message that the command was not found.

Example:

```
MVME3100> mytest  
"mytest" not found  
MVME3100>
```

If the user enters a partial MOTLoad command string that can be resolved to a unique valid MOTLoad command and presses the carriage-return key, the command will be executed as if the entire command string had been entered. This feature is a user-input shortcut that minimizes the required amount of command line input. MOTLoad is an ever changing firmware package, so user-input shortcuts may change as command additions are made.

Example:

```
MVME3100> version  
Copyright: Motorola Inc.1999-2002, All Rights Reserved  
MOTLoad RTOS Version 2.0  
PAL Version 0.1 (Motorola MVME3100)
```

Example:

```
MVME3100> ver  
Copyright: Motorola Inc. 1999-2002, All Rights Reserved  
MOTLoad RTOS Version 2.0  
PAL Version 0.1 (Motorola MVME3100)
```

If the partial command string cannot be resolved to a single unique command, MOTLoad will inform the user that the command was ambiguous.

Example:

```
MVME3100> te  
"te" ambiguous  
MVME3100>
```

3.4.1 Command Line Rules

There are a few things to remember when entering a MOTLoad command:

- Multiple commands are permitted on a single command line, provided they are separated by a single semicolon (;)

MOTLoad Firmware

- Spaces separate the various fields on the command line (command/arguments/options)
- The argument/option identifier character is always preceded by a hyphen (-) character
- Options are identified by a single character
- Option arguments immediately follow (no spaces) the option
- All commands, command options, and device tree strings are case sensitive

Example:

```
MVME3100> flashProgram -d/dev/flash0 -n00100000
```

For more information on MOTLoad operation and function, refer to the *MOTLoad Firmware Package User's Manual*.

3.4.2 Command Line Help

Each MOTLoad firmware package has an extensive, product-specific help facility that can be accessed through the `help` command. The user can enter `help` at the MOTLoad command line to display a complete listing of all available tests and utilities.

Example:

```
MVME3100> help
```

For help with a specific test or utility the user can enter the following at the MOTLoad prompt:

```
help <command_name>
```

The `help` command also supports a limited form of pattern matching. Refer to the help command page.

Example

```
MVME3100> help testRam
Usage: testRam [-aPh] [-bPh] [-iPd] [-nPh] [-tPd] [-v]
Description: RAM Test [Directory]
Argument/Option Description
-a Ph: Address to Start (Default = Dynamic Allocation)
-b Ph: Block Size (Default = 16KB)
-i Pd: Iterations (Default = 1)
-n Ph: Number of Bytes (Default = 1MB)
-t Ph: Time Delay Between Blocks in OS Ticks (Default = 1)
-v O : Verbose Output
MVME3100>
```

3.5 Firmware Settings

The following sections provide additional information pertaining to the VME firmware settings of the MVME3100. A few VME settings are controlled by hardware jumpers while the majority of the VME settings are managed by the firmware command utility `vmeCfg`.

3.5.1 Default VME Settings

As shipped from the factory, the MVME3100 has the following VME configuration programmed via Global Environment Variables (GEVs) for the Tsi148 VME controller. The firmware allows certain VME settings to be changed in order for the user to customize the environment. The following is a description of the default VME settings that are changeable by the user. For more information, refer to the *MOTLoad User's Manual* and IDT's *Tsi148 User Manual*, listed in [Appendix 9, Related Documentation](#).

```
MVME3100> vmeCfg -s -m
Displaying the selected Default VME Setting
- interpreted as follows:
VME PCI Master Enable [Y/N] = Y
MVME3100>
```

The PCI Master is enabled.

```
MVME3100> vmeCfg -s -r234
Displaying the selected Default VME Setting
- interpreted as follows:
VMEbus Master Control Register = 00000003
MVME3100>
```

The VMEbus Master Control Register is set to the default (RESET) condition.

```
MVME3100> vmeCfg -s -r238
Displaying the selected Default VME Setting
- interpreted as follows:
VMEbus Control Register = 00000008
MVME3100>
```

The VMEbus Control Register is set to a Global Timeout of 2048 μ seconds.

```
MVME3100> vmeCfg -s -r414
```

MOTLoad Firmware

```
Displaying the selected Default VME Setting
- interpreted as follows:
CRG Attribute Register = 00000000
CRG Base Address Upper Register = 00000000
CRG Base Address Lower Register = 00000000
MVME3100>
```

The CRG Attribute Register is set to the default (RESET) condition.

```
MVME3100> vmeCfg -s -i0

Displaying the selected Default VME Setting
- interpreted as follows:
Inbound Image 0 Attribute Register = 000227AF
Inbound Image 0 Starting Address Upper Register = 00000000
Inbound Image 0 Starting Address Lower Register = 00000000
Inbound Image 0 Ending Address Upper Register = 00000000
Inbound Image 0 Ending Address Lower Register = 1FFF0000
Inbound Image 0 Translation Offset Upper Register = 00000000
Inbound Image 0 Translation Offset Lower Register = 00000000
MVME3100>
```

Inbound window 0 (ITAT0) is not enabled; Virtual FIFO at 256 bytes, 2eSST timing at SST320, respond to 2eSST, 2eVME, MBLT, and BLT cycles, A32 address space, respond to Supervisor, User, Program, and Data cycles. Image maps from 0x00000000 to 0x1FFF0000 on the VMBus, translates 1x1 to the PCI-X bus (thus 1x1 to local memory). To enable this window, set bit 31 of ITAT0 to 1.



For Inbound Translations, the Upper Translation Offset Register needs to be set to 0xFFFFFFFF to ensure proper translations to the PCI-X Local Bus.

```
MVME3100> vmeCfg -s -o1

Displaying the selected Default VME Setting
- interpreted as follows:
Outbound Image 1 Attribute Register = 80001462
Outbound Image 1 Starting Address Upper Register = 00000000
Outbound Image 1 Starting Address Lower Register = 91000000
Outbound Image 1 Ending Address Upper Register = 00000000
Outbound Image 1 Ending Address Lower Register = AFFF0000
```

```
Outbound Image 1 Translation Offset Upper Register = 00000000
Outbound Image 1 Translation Offset Lower Register = 70000000
Outbound Image 1 2eSST Broadcast Select Register = 00000000
MVME3100>
```

Outbound window 1 (OTAT1) is enabled, 2eSST timing at SST320, transfer mode of 2eSST, A32/D32 Supervisory access. The window accepts transfers on the PCI-X Local Bus from 0x91000000-0xAFFF0000 and translates them onto the VMEbus using an offset of 0x70000000, thus an access to 0x91000000 on the PCI-X Local Bus becomes an access to 0x01000000 on the VMEbus.

```
MVME3100> vmeCfg -s -o2
```

```
Displaying the selected Default VME Setting
```

```
- interpreted as follows:
```

```
Outbound Image 2 Attribute Register = 80001061
Outbound Image 2 Starting Address Upper Register = 00000000
Outbound Image 2 Starting Address Lower Register = B0000000
Outbound Image 2 Ending Address Upper Register = 00000000
Outbound Image 2 Ending Address Lower Register = B0FF0000
Outbound Image 2 Translation Offset Upper Register = 00000000
Outbound Image 2 Translation Offset Lower Register = 40000000
Outbound Image 2 2eSST Broadcast Select Register = 00000000
MVME3100>
```

Outbound window 2 (OTAT2) is enabled, 2eSST timing at SST320, transfer mode of SCT, A24/D32 Supervisory access. The window accepts transfers on the PCI-X Local Bus from 0xB0000000-0xB0FF0000 and translates them onto the VMEbus using an offset of 0x40000000, thus an access to 0xB0000000 on the PCI-X Local Bus becomes an access to 0xF0000000 on the VMEbus.

```
MVME3100> vmeCfg -s -o3
```

```
Displaying the selected Default VME Setting
```

```
- interpreted as follows:
```

```
Outbound Image 3 Attribute Register = 80001061
Outbound Image 3 Starting Address Upper Register = 00000000
Outbound Image 3 Starting Address Lower Register = B3FF0000
Outbound Image 3 Ending Address Upper Register = 00000000
Outbound Image 3 Ending Address Lower Register = B3FF0000
Outbound Image 3 Translation Offset Upper Register = 00000000
Outbound Image 3 Translation Offset Lower Register = 4C000000
Outbound Image 3 2eSST Broadcast Select Register = 00000000
MVME3100>
```

MOTLoad Firmware

Outbound window 3 (OTAT3) is enabled, 2eSST timing at SST320, transfer mode of SCT, A16/D32 Supervisory access. The window accepts transfers on the PCI-X Local Bus from 0xB3FF0000-0xB3FF0000 and translates them onto the VMEbus using an offset of 0x4C000000, thus an access to 0xB3FF0000 on the PCI-X Local Bus becomes an access to 0xFFFF0000 on the VMEbus.

```
MVME3100> vmeCfgr -s -o7
```

```
Displaying the selected Default VME Setting
```

```
- interpreted as follows:
```

```
Outbound Image 7 Attribute Register = 80001065
```

```
Outbound Image 7 Starting Address Upper Register = 00000000
```

```
Outbound Image 7 Starting Address Lower Register = B1000000
```

```
Outbound Image 7 Ending Address Upper Register = 00000000
```

```
Outbound Image 7 Ending Address Lower Register = B1FF0000
```

```
Outbound Image 7 Translation Offset Upper Register = 00000000
```

```
Outbound Image 7 Translation Offset Lower Register = 4F000000
```

```
Outbound Image 7 2eSST Broadcast Select Register = 00000000
```

```
MVME3100>
```

Outbound window 7 (OTAT7) is enabled, 2eSST timing at SST320, transfer mode of SCT, CR/CSR Supervisory access. The window accepts transfers on the PCI-X Local Bus from 0xB1000000-0xB1FF0000 and translates them onto the VMEbus using an offset of 0x4F000000, thus an access to 0xB1000000 on the PCI-X Local Bus becomes an access to 0x00000000 on the VMEbus.

3.5.2 Control Register/Control Status Register Settings

The CR/CSR base address is initialized to the appropriate setting based on the Geographical address; that is, the VME slot number. See the VME64 Specification and the VME64 Extensions for details. As a result, a 512K byte CR/CSR area can be accessed from the VMEbus using the CR/CSR AM code.

3.5.3 Displaying VME Settings

To display the changeable VME setting, type the following at the firmware prompt:

```
vmeCfgr -s -m: Displays Master Enable state
```

```
vmeCfgr -s -i(0 - 7): Displays selected Inbound Window state
```

```
vmeCfgr -s -o(0 - 7): Displays selected Outbound Window state
```

```
vmeCfgr -s -r184: Displays PCI Miscellaneous Register state
```

```
vmeCfgr -s -r188: Displays Special PCI Target Image Register state
```

vmeCfg -s -r400: Displays Master Control Register state
vmeCfg -s -r404: Displays Miscellaneous Control Register state
vmeCfg -s -r40C: Displays User AM Codes Register state
vmeCfg -s -rF70: Displays VMEbus Register Access Image Control Register state

3.5.4 Editing VME Settings

To edit the changeable VME setting, type the following at the firmware prompt:

vmeCfg -e -m: Edits Master Enable state
vmeCfg -e -i(0 - 7): Edits selected Inbound Window state
vmeCfg -e -o(0 - 7): Edits selected Outbound Window state
vmeCfg -e -r184: Edits PCI Miscellaneous Register state
vmeCfg -e -r188: Edits Special PCI Target Image Register state
vmeCfg -e -r400: Edits Master Control Register state
vmeCfg -e -r40: Edits Miscellaneous Control Register state
vmeCfg -e -r40C: Edits User AM Codes Register state
vmeCfg -e -rF70: Edits VMEbus Register Access Image Control Register state

3.5.5 Deleting VME Settings

To delete the changeable VME setting (restore default value), type the following at the firmware prompt:

vmeCfg -d -m: Deletes Master Enable state
vmeCfg -d -i(0 - 7): Deletes selected Inbound Window state
vmeCfg -d -o(0 - 7): Deletes selected Outbound Window state
vmeCfg -d -r184: Deletes PCI Miscellaneous Register state
vmeCfg -d -r188: Deletes Special PCI Target Image Register state
vmeCfg -d -r400: Deletes Master Control Register state
vmeCfg -d -r404: Deletes Miscellaneous Control Register state
vmeCfg -d -r40C: Deletes User AM Codes Register state
vmeCfg -d -rF70: Deletes VMEbus Register Access Image Control Register state

3.5.6 Restoring Default VME Settings

To restore all of the changeable VME setting back to their default settings, type the following at the firmware prompt: `vmeCfg -z`

3.6 Remote Start

As described in the *MOTLoad Firmware Package User's Manual*, listed in [Appendix 9, Related Documentation](#), remote start allows the user to obtain information about the target board, download code and/or data, modify memory on the target, and execute a downloaded program. These transactions occur across the VMEbus in the case of the MVME3100. MOTLoad uses one of four mailboxes in the Tsi148 VME controller as the inter-board communication address (IBCA) between the host and the target.

CR/CSR slave addresses configured by MOTLoad are assigned according to the installation slot in the backplane, as indicated by the *VME64 Specification*. For reference, the following values are provided:

Slot Position	CS/CSR Starting Address
1	0x0008.0000
2	0x0010.0000
3	0x0018.0000
4	0x0020.0000
5	0x0028.0000
6	0x0030.0000
7	0x0038.0000
8	0x0040.0000
9	0x0048.0000
A	0x0050.0000
B	0x0058.0000
C	0x0060.0000

For further details on CR/CSR space, please refer to the *VME64 Specification*, listed in [Appendix 9, Related Documentation](#).

The MVME3100 uses a Discovery II for its VME bridge. The offsets of the mailboxes in the Discovery II are defined in the *Discovery II User Manual*, listed in [Appendix 9, Related Documentation](#), but are noted here for reference:

Mailbox 0 is at offset 7f348 in the CR/CSR space

Mailbox 1 is at offset 7f34C in the CR/CSR space

Mailbox 2 is at offset 7f350 in the CR/CSR space

Mailbox 3 is at offset 7f354 in the CR/CSR space

The selection of the mailbox used by remote start on an individual MVME3100 is determined by the setting of a global environment variable (GEV). The default mailbox is zero. Another GEV controls whether remote start is enabled (default) or disabled. Refer to the *Remote Start* appendix in the *MOTLoad Firmware Package User's Manual* for remote start GEV definitions.

The MVME3100's IBCA needs to be mapped appropriately through the master's VMEbus bridge. For example, to use remote start using mailbox 0 on an MVME3100 installed in slot 5, the master would need a mapping to support reads and writes of address 0x002ff348 in VME CR/CSR space (0x280000 + 0x7f348).

3.7 Alternate Boot Images and Safe Start

Some later versions of MOTLoad support Alternate Boot Images and a Safe Start recovery procedure. If Safe Start is available on the MVME3100, Alternate Boot Images are supported. With Alternate Boot Image support, the bootloader code in the boot block examines the upper 8MB of the flash bank for Alternate Boot images. If an image is found, control is passed to the image.

3.8 Firmware Startup Sequence Following Reset

The firmware startup sequence following reset of MOTLoad is to:

- Initialize cache, MMU, FPU, and other CPU internal items
- Initialize the memory controller
- Search the active flash bank, possibly interactively, for a valid POST image. If found, the POST image executes. Once completed, the POST image returns and startup continues.
- Search the active flash bank, possibly interactively, for a valid USER boot image. If found, the USER boot image executes. A return to the boot block code is not anticipated.
- If a valid USER boot image is not found, search the active flash bank, possibly interactively, for a valid MCG boot image; anticipated to be upgrade of MCG firmware. If found, the image is executed. A return to the boot block code is not anticipated.
- Execute the recovery image of the firmware in the boot block if no valid USER or MCG image is found

During startup, interactive mode may be entered by either setting the Safe Start jumper/switch or by sending an <ESC> to the console serial port within five seconds of the board reset. During interactive mode, the user has the option to display locations at which valid boot images were discovered, specify which discovered image is to be executed, or specify that the recovery image in the boot block of the active flash bank is to be executed.

3.9 Firmware Scan for Boot Image

The scan is performed by examining each 1MB boundary for a defined set of flags that identify the image as being Power On Self Test (POST), USER, or MCG. MOTLoad is an MCG image. POST is a user-developed Power On Self Test that would perform a set of diagnostics and then return to the bootloader image. User would be a boot image, such as the VxWorks bootrom, which would perform board initialization. A bootable VxWorks kernel would also be a USER image. Boot images are not restricted to being MB or less in size; however, they must begin on a 1MB boundary within the 8MB of the scanned flash bank. The flash bank structure is shown below:

Address	Usage
0xFFFF0000 to 0xFFFFFFFF	Boot block. Recovery code
0xFFE00000 to 0xFFFFFFFF	Reserved for MCG use. (MOTLoad update image)
0xFFD00000 to 0xFFDFFFFF (FBD00000 or F7D00000)	First possible alternate image (Bank B / Bank A actual)
0xFFC00000 to 0xFFCFFFFF (FBC00000 or F7C00000)	Second possible alternate image (Bank B / Bank A actual)
....	Alternate boot images
0xFF899999 to 0xFF8FFFFF (Fb800000 or F3800000)	Last possible alternate image (Bank B / Bank A actual)

The scan is performed downwards from boot block image and searches first for POST, then USER, and finally MCG images. In the case of multiple images of the same type, control is passed to the first image encountered in the scan.

Safe Start, whether invoked by hitting **ESC** on the console within the first five seconds following power-on reset or by setting the Safe Start jumper, interrupts the scan process. The user may then display the available boot images and select the desired image. The feature is provided to enable recovery in cases when the programmed Alternate Boot Image is no longer desired. The following output is an example of an interactive Safe Start:

```

ABCDEInteractive Boot Mode Entered
boot> ?
Interactive boot commands:
'd':show directory of alternate boot images
'c':continue with normal startup
'q':quit without executing any alternate boot image
'r [address]':execute specified (or default) alternate image
'p [address]':execute specified (or default) POST image
'?':this help screen
'h':this help screen
boot> d
Addr FFE00000 Size 00100000 Flags 00000003 Name: MOTLoad
Addr FFD00000 Size 00100000 Flags 00000003 Name: MOTLoad
boot> c
NOPQRSTUVWXYZabcdefghijklmnopqrsstuvwxyzWXYZ
Copyright Motorola Inc. 1999-2004, All Rights Reserved
MOTLoad RTOS Version 2.0, PAL Version 0.b EA02

...

MVME3100>

```

3.10 Boot Images

Valid boot images whether POST, USER, or MCG, are located on 1MB boundaries within flash. The image may exceed 1MB in size. An image is determined valid through the presence of two "valid image keys" and other sanity checks. A valid boot image begins with a structure as defined in the following table:

Name	Type	Size	Notes
UserDefined	unsigned integer	8	User defined
ImageKey 1	unsigned integer	1	0x414c5420
ImageKey 2	unsigned integer	1	0x424f4f54
ImageChecksum	unsigned integer	1	Image checksum
ImageSize	unsigned integer	1	Must be a multiple of 4
ImageName	unsigned character	32	User defined
ImageRamAddress	unsigned integer	1	RAM address

Name	Type	Size	Notes
ImageOffset	unsigned integer	1	Offset from header start to entry
ImageFlags	unsigned integer	1	Refer to <i>Image Flags on page 60</i>
ImageVersion	unsigned integer	1	User defined
Reserved	unsigned integer	8	Reserved for expansion

3.10.1 Checksum Algorithm

The checksum algorithm is a simple unsigned word add of each word (4 byte) location in the image. The image must be a multiple of 4 bytes in length (word-aligned). The content of the checksum location in the header is not part of the checksum calculation. The calculation assumes the location to be zero.

The algorithm is implemented using the following code:

```
Unsigned int checksum(  
    Unsigned int *startPtr, /* starting address */  
    Unsigned int endPtr /* ending address */  
    ) {  
    unsigned int checksum=0;  
    while (startPtr < endPtr) {  
        checksum += *startPtr;  
        startPtr++;  
    }  
    return(checksum);  
}
```

3.10.2 Image Flags

The image flags of the header define various bit options that control how the image will be executed.

Name	Value	Interpretation
COPY_TO_RAM	0x00000001	Copy image to RAM at ImageRamAddress before execution
IMAGE_MCG	0x00000002	MCG-specific image
IMAGE_POST	0x00000004	POST image
DONT_AUTO_RUN	0x00000008	Image not to be executed

COPY_TO_RAM

If set, this flag indicates that the image is to be copied to RAM at the address specified in the header before control is passed. If not set, the image will be executed in flash. In both instances, control will be passed at the image offset specified in the header from the base of the image.

IMAGE_MCG

If set, this flag defines the image as being an Alternate MOTLoad, as opposed to USER, image. This bit should not be set by developers of alternate boot images.

IMAGE_POST

If set, this flag defines the image as being a power-on self-test image. This bit flag is used to indicate that the image is a diagnostic and should be run prior to running either USER or MCG boot images. POST images are expected, but not required, to return to the boot block code upon completion.

DONT_AUTO_RUN

If set, this flag indicates that the image is not to be selected for automatic execution. A user, through the interactive command facility, may specify the image to be executed.



MOTLoad currently uses an Image Flag value of 0x3, which identifies itself as an Alternate MOTLoad image that executes from RAM. MOTLoad currently does not support execution from flash.

3.10.3 User Images

These images are user-developer boot code; for example, a VxWorks bootrom image. Such images may expect the system software state to be as follows upon entry:

- The MMU is disabled.
- L1 instruction cache has been initialized and is enabled.
- L1 data cache has been initialized (invalidated) and is disabled.
- L2 cache is disabled.
- L3 cache is disabled.
- RAM has been initialized and is mapped starting at CPU address 0.
- If RAM ECC or parity is supported, RAM has been scrubbed of ECC or parity errors.
- The active flash bank (boot) is mapped from the upper end of the address space.

- If specified by COPY_TO_RAM, the image has been copied to RAM at the address specified by `ImageRamAddress`.
- CPU register R1 (the stack pointer) has been initialized to a value near the end of RAM.
- CPU register R3 is added to the following structure:

```
typedef struct altBootData {
    unsigned int ramSize; /* board's RAM size in MB */
    void flashPtr; /* ptr to this image in flash */
    char boardType[16]; /* name string, eg MVME3100 */
    void globalData; /* 16K, zeroed, user defined */
    unsigned int reserved[12];
} altBootData_t;
```

3.10.4 Alternate Boot Data Structure

The `globalData` field of the alternate boot data structure points to an area of RAM which was initialized to zeros by the boot loader. This area of RAM is not cleared by the boot loader after execution of a POST image, or other alternate boot image, is executed. It is intended to provide a user a mechanism to pass POST image results to subsequent boot images.

The boot loader performs no other initialization of the board than that specified prior to the transfer of control to either a POST, USER, or MCG image. Alternate boot images need to initialize the board to whatever state the image may further require for its execution.

POST images are expected, but not required, to return to the boot loader. Upon return, the boot loader proceeds with the scan for an executable alternate boot image. POST images that return control to the boot loader must ensure that upon return, the state of the board is consistent with the state that the board was in at POST entry. USER images should not return control to the boot loader.

3.10.5 Alternate Boot Images and Safe Start

Some later versions of MOTLoad support alternate boot images and a safe start recovery procedure. If safe start is available on the MVME3100, alternate boot images are supported. With alternate boot image support, the boot loader code in the boot block examines the upper 8MB of the flash bank for alternate boot images. If an image is found, control is passed to the image.

3.10.6 Boot Image Firmware Scan

The scan is performed by examining each 1MB boundary for a defined set of flags that identify the image as being POST, USER, or Alternate MOTLoad. POST is a user-developed Power On Self Test that would perform a set of diagnostics and then return to the boot loader image. USER would be a boot image, such as the VxWorks bootrom, which would perform board initialization. A bootable VxWorks kernel would also be a USER image. Boot images are not restricted to being 1MB or less in size; however, they must begin on a 1MB boundary within the 8MB of the scanned flash bank. The flash bank structure is shown below:

Address	Usage
0xFFF00000 to 0xFFFFFFFF	Boot block. Recovery code.
0xFFE00000 to 0xFFFFFFFF	Backup MOTLoad image
0xFFD00000 to 0xFFDFFFFFF	First possible alternate image
0xFFC00000 to 0xFFCFFFFFF	Second possible alternate image
....	Alternate boot images
0xFF899999 to 0xFF8FFFFFF	Bottom of flash (it size varies per product)

The scan is performed downwards beginning at the location of the first possible alternate image and searches first for POST, then USER, and finally Alternate MOTLoad images. In the case of multiple images of the same type, control is passed to the first image encountered in the scan.

Safe Start, whether invoked by hitting ESC on the console within the first five seconds following power-on reset or by setting the Safe Start jumper, interrupts the scan process. The user may then display the available boot images and select the desired image. The feature is provided to enable recovery in cases when the programmed Alternate Boot image is no longer desired. The following output is an example of an interactive Safe Start:

```

ABCDEInteractive Boot Mode Entered
boot> ?
Interactive boot commands:
'd':show directory of alternate boot images
'c':continue with normal startup
'q':quit without executing any alternate boot image
'r [address]':execute specified (or default) alternate image
'p [address]':execute specified (or default) POST image
'?':this help screen
'h':this help screen
boot> d
Addr FFE00000 Size 00100000 Flags 00000003 Name: MOTLoad

```

MOTLoad Firmware

```
Addr FFD00000 Size 00100000 Flags 00000003 Name: MOTLoad
boot> c
NOPQRSTUVWXYZabcdefghijklmnopqrstuvwxyzWXXZ
Copyright Motorola Inc. 1999-2004, All Rights Reserved
MOTLoad RTOS Version 2.0, PAL Version 0.b EA02

...

MVME3100>
```

3.11 Startup Sequence

The firmware startup sequence following reset of MOTLoad is to:

- Initialize cache, MMU, FPU, and other CPU internal items
- Initialize the memory controller
- Search the active flash bank, possibly interactively, for a valid Power On Self Test (POST) image. If found, the POST image executes. Once completed, the POST image returns and startup continues.
- Search the active flash bank, possibly interactively, for a valid USER boot image. If found, the USER boot image executes. A return to the boot block code is not anticipated.
- If a valid USER boot image is not found, search the active flash bank, possibly interactively, for a valid Alternate MOTLoad boot image; anticipated to be an upgrade of alternate MOTLoad firmware. If found, the image is executed. A return to the boot block code is not anticipated.
- Execute the recovery image of the firmware in the boot block if no valid USER or alternate MOTLoad image is found

During startup, interactive mode may be entered by either setting the Safe Start jumper/switch or by sending an <ESC> to the console serial port within five seconds of the board reset. During interactive mode, the user has the option to display locations at which valid boot images were discovered, specify which discovered image is to be executed, or specify that the recovery image in the boot block of the active flash bank is to be executed.

Functional Description

4.1 Introduction

This chapter describes the MVME3100 and the MVME721 rear transition module (RTM) on a block diagram level.

4.2 Features

The following tables list the features of the MVME3100 and its RTM.

Table 4-1 MVME3100 Features Summary

Feature	Description
Processor/Host Controller/Memory Controller	<ul style="list-style-type: none"> – Single 833MHz MPC8540 PowerQUICC III™ integrated processor (e500 core) – Integrated 256KB L2 cache/SRAM – Integrated four-channel DMA controller – Integrated PCI/PCI-X controller – Two integrated 10/100/1000 Ethernet controllers – Integrated 10/100 Ethernet controller – Integrated dual UART – Integrated I2C controller – Integrated programmable interrupt controller – Integrated local bus controller – Integrated DDR SDRAM controller
System Memory	<ul style="list-style-type: none"> – One SODIMM socket – Up to DDR333, ECC – One or two banks of memory on a single SODIMM
I ² C Interface	<ul style="list-style-type: none"> – One 8KB VPD serial EEPROM – Two 64KB user configuration serial EEPROMs – One real-time clock (RTC) with removable battery – One temperature sensor – Interface to SPD(s) on SODIMM and P2 for RTM VPD
Flash	<ul style="list-style-type: none"> – 128MB soldered flash with two alternate 1MB boot sectors selectable via a hardware switch – Hardware switch or software bit write protection for entire logical bank

Functional Description

Table 4-1 MVME3100 Features Summary (continued)

Feature	Description
PCI Interface	Bus A: – 66MHz PCI-X mode – One TSi148 VMEbus controller – One serial ATA (SATA) controller – One MPC8540 – Two PCI6520 PCI-X-to-PCI-X bridges (primary side)
	Bus B: – 33/66/100MHz PCI/PCI-X (PCI 2.2 and PCI-X 1.0b compliant) – Two +3.3V/5V selectable VIO, 64-bit, single-wide PMC sites or one double-wide PMC site (PrPMC ANSI/VITA 32-2003 and PCI-X Auxiliary ANSI/VITA 39-2003 compliant) – One PCI6520 PCI-X-to-PCI-X bridge (secondary side)
	Bus C (-1263 version): – 33MHz PCI (PCI 2.2 compliant) – One USB 2.0 controller – One PCI expansion connector for interface to PMCspan – One PCI6520 PCI-X-to-PCI-X bridge (secondary side)
I/O	– One front panel RJ-45 connector with integrated LEDs for front I/O: one serial channel – One front panel RJ-45 connector with integrated LEDs for front I/O: one 10/100/1000 Ethernet channel – One front panel external SATA data connector for front I/O: one SATA channel – One front panel USB Type A upright receptacle for front I/O: one USB 2.0 channel (-1263 version) – PMC site 1 front I/O and rear P2 I/O – PMC site 2 front I/O
Serial ATA	– One four-channel SATA controller: one channel for front-panel I/O, one channel for planar I/O, one channel for future rear P0 I/O, and one channel is not used – One planar data connector and one planar power connector for an interface to the SATA hard disk drive
USB (-1263 version)	– One four-channel USB 2.0 controller: one channel for front panel
Ethernet	– Two 10/100/1000 MPC8540 Ethernet channels for front-panel I/O and rear P2 I/O – One 10/100 MPC8540 Ethernet channel for rear P2 I/O

Table 4-1 MVME3100 Features Summary (continued)

Feature	Description
Serial Interface	<ul style="list-style-type: none"> – One 16550-compatible, 9.6 to 115.2 KBAUD, MPC8540, asynchronous serial channel for front-panel I/O – One quad UART controller to provide four 16550-compatible, 9.6 to 115.2 KBAUD, asynchronous serial channels for rear P2 I/O
Timers	<ul style="list-style-type: none"> – Four 32-bit MPC8540 timers – Four 32-bit timers in a PLD
Watchdog Timer	<ul style="list-style-type: none"> – One MPC8540 watchdog timer
VME Interface	<ul style="list-style-type: none"> – VME64 (ANSI/VITA 1-1994) compliant – VME64 Extensions (ANSI/VITA 1.1-1997) compliant – 2eSST (ANSI/VITA 1.5-2003) compliant – VITA 41.0, version 0.9 compliant – Two five-row P1 and P2 backplane connectors – One TSi148 VMEbus controller
Form Factor	<ul style="list-style-type: none"> – Standard 6U VME
Miscellaneous	<ul style="list-style-type: none"> – One front-panel reset/abort switch – Four front-panel status indicators: 10/100/1000 Ethernet link/speed and activity, board fail, and user software controlled LED – Six planar status indicators: one power supply status LED, two user software controlled LEDs, three SATA activity LEDs (one per channel) – One standard 16-pin COP header – Boundary scan support – Switches for VME geographical addressing in a three-row backplane
Software Support	<ul style="list-style-type: none"> – VxWorks operating system – Linux operating system

Table 4-2 MVME721 RTM Features Summary

Feature	Description
I/O	<ul style="list-style-type: none"> – One five-row P2 backplane connector for serial and Ethernet I/O passed from the MVME3100 – Four RJ-45 connectors for rear-panel I/O: four asynchronous serial channels – Two RJ-45 connectors with integrated LEDs for rear panel I/O: one 10/100/1000 Ethernet channel and one 10/100 Ethernet channel – One PIM site with rear-panel I/O
Miscellaneous	<ul style="list-style-type: none"> – Four status indicators: 10/100/1000 and 10/100 Ethernet link/speed and activity LEDs

4.3 Block Diagrams

Figure 4-1 shows a block diagram of the overall board architecture and Figure 4-2 shows a block diagram of the MVME721 rear transition module architecture.

Figure 4-1 MVME3100 Block Diagram

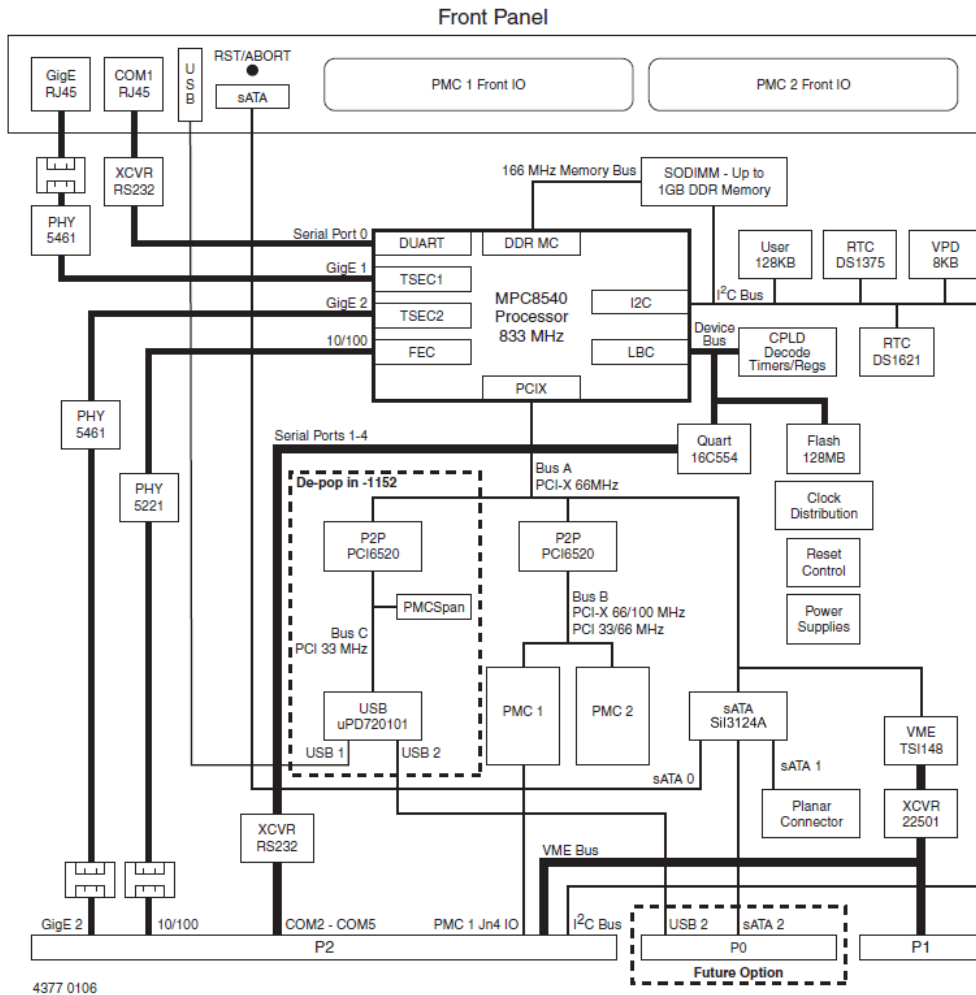
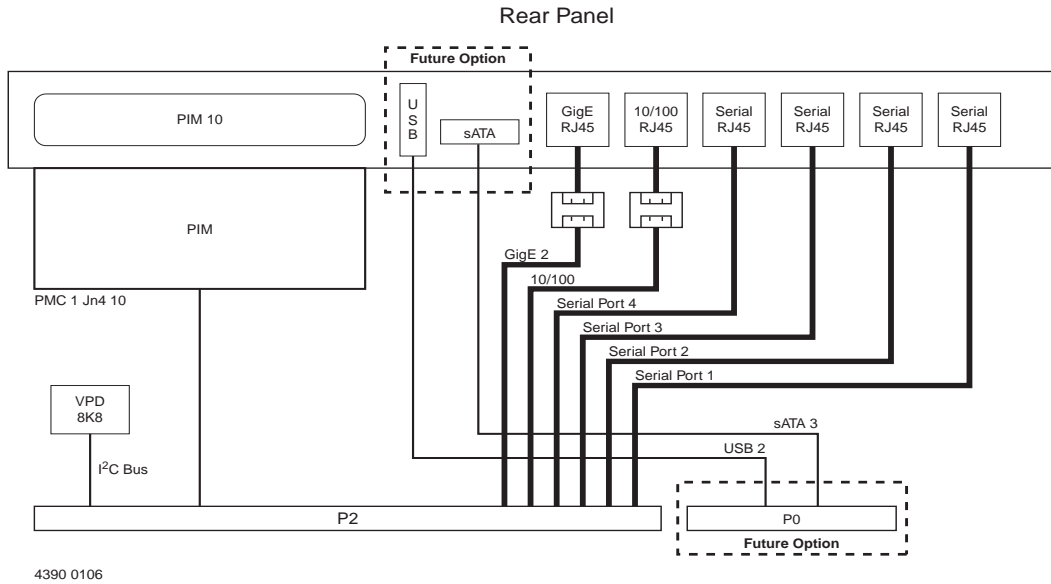

Figure 4-2 MVME721 RTM Block Diagram



4.4 Processor

The MVME3100 supports the MPC8540 processor. The processor core frequency runs at 833MHz or 667MHz. The MPC8540 has integrated 256KB L2 cache.

4.5 System Memory

The MPC8540 provides one standard DDR SDRAM SODIMM socket. This socket supports standard single or dual bank, unbuffered, SSTL-2 DDR-I, JESD8-9B compliant, SODIMM module with ECC. The MPC8540 DDR memory interface supports up to 166MHz (333MHz data rate) operation.

4.6 Local Bus Interface

The MVME3100 uses the MPC8540 local bus controller (LBC) for access to on-board flash and I/O registers. The LBC has programmable timing modes to support devices of different access times, as well as device widths of 8, 16, and 32 bits.

Functional Description

The MVME3100 uses the LBC in General Purpose Chip Select Machine (GPCM) mode to interface to two physical banks of on-board flash, an on-board quad UART (QUART), on-board 32-bit timers, and the System Control/Status registers. Refer to the *MVME3100 Single Board Computer Programmer's Reference Guide* listed in [Appendix 9, Related Documentation](#), for the LBC bank and chip select assignments.

4.6.1 Flash Memory

The MVME3100 provides one physical bank of soldered-on flash memory. The bank is composed of two physical flash devices configured to operate in 16-bit mode to form a 32-bit flash bank. The default configuration for the MVME3100-1263 is 128MB using two 512Mb devices, and for the MVME3100-1152 it is 64MB using two 256Mb devices.

Refer to the *MVME3100 Single Board Computer Programmer's Reference Guide* listed in [Appendix 9, Related Documentation](#), for more information.

4.6.2 Control and Timers Logic

The MVME3100 control and timers logic resides on the local bus. This logic provides the following functions on the board:

- Local bus address latch
- Chip selects for flash banks and QUART
- System Control and Status registers
- Four 32-bit tick timers
- Real-time clock (RTC) 1MHz reference clock

Refer to the *MVME3100 Single Board Computer Programmer's Reference Guide* listed in [Appendix 9, Related Documentation](#), for more information.

4.7 I²C Serial Interface and Devices

The MVME3100 provides the following on-board I2C serial devices connected to the MPC8540 I2C controller interface:

- 8KB serial EEPROM for VPD
- Two 64KB serial EEPROMs for user configuration data storage
- 256 byte serial EEPROM on SODIMM for SPD
- Maxim DS1375 RTC
- Maxim DS1621 temperature sensor
- 8KB serial EEPROM on RTM VPD

The Maxim DS1375 RTC implemented on the MVME3100 provides an alarm interrupt routed to the MPC8540 programmable interrupt controller (PIC). A Maxim DS32KHz temperature controlled crystal oscillator provides the RTC reference. A battery backup circuit for the RTC is provided on board.

The Maxim DS1621 digital temperature sensor provides a measure of the temperature of the board.

The I²C interface is also routed to the on-board SODIMM socket. This allows the serial presence detect (SPD) in the serial EEPROM, which is located on the memory module, to be read and used to configure the memory controller accordingly. Similarly, the I2C interface is routed to the P2 connector for access to the serial EEPROM located on the RTM. The device address for the RTM serial EEPROM is user-selectable using configuration switches on the RTM.

Refer to the *MVME3100 Single Board Computer Programmer's Reference Guide* in [Appendix 9, Related Documentation](#), for more information.

4.8 Ethernet Interfaces

The MVME3100 provides one 10/100 and two 10/100/1000 Mb/s full duplex Ethernet interfaces using the MPC8540 Fast Ethernet Controller (FEC) and two Triple Speed Ethernet Controllers (TSEC). A Broadcom BCM5461S PHY is used for each TSEC interface, and each TSEC interface and PHY is configured to operate in GMII mode. One Gigabit Ethernet interface is routed to a front-panel RJ-45 connector with integrated LEDs for speed and activity indication. The other Gigabit Ethernet interface is routed to P2 for rear I/O.

A Broadcom BCM5221 PHY is used for the FEC interface. The Fast Ethernet interface is routed to P2 for rear I/O. Isolation transformers are provided on-board for each interface. The assigned PHY addresses for the MPC8540 MII management (MIIM) interface can be found in the *MVME3100 Single Board Computer Programmer's Reference Guide*, listed in [Appendix 9, Related Documentation](#).

Each Ethernet interface is assigned an Ethernet Station Address. The address is unique for each device. The Ethernet Station Addresses are displayed on labels attached to the PMC front-panel keep-out area.

4.9 Asynchronous Serial Ports

The MVME3100 board contains one front-access asynchronous serial port interface using serial port 0 from the MPC8540 dual UART (DUART) device. This serial port is routed to the RJ-45 front-panel connector.

Functional Description

This board also contains one quad UART (QUART) device connected to the MPC8540 device controller bus to provide additional asynchronous serial ports. The QUART provides four asynchronous serial ports, SP1 – SP4, which are routed to the P2 connector. Refer to the *ST16C554D Data Sheet* listed in [Appendix 9, Related Documentation](#), for additional details and/or programming information.

4.10 PCI/PCI-X Interfaces and Devices

The MVME3100 provides three separate PCI/PCI-X bus segments. Bus segment A operates in 66MHz PCI-X mode and is connected to the MPC8540, the Tsi148 VME controller, the serial ATA (SATA) controller, and two PCI-X-to-PCI-X bridges. Bus segment B is bridged between bus A and the two PMC sites and operates in 33/66MHz PCI or 66/100MHz PCI-X mode depending on the slowest speed PMC installed. Bus segment C is bridged between bus A, the USB controller, and the PMCspan connector. Bus C operates at 33MHz PCI mode.

4.10.1 MPC8540 PCI-X Interface

The MPC8540 PCI-X controller is configured to operate in PCI-X mode only, host bridge mode. Bus A mode switch must be in OFF position in order to be fixed in PCI-X mode. The mode cannot be changed by software. Refer to the *MPC8540 Reference Manual* listed in [Appendix 9, Related Documentation](#), for additional details and/or programming information.

4.10.2 TSi148 VME Controller

The VMEbus interface for the MVME3100 is provided by the TSi148 ASIC. The TSi148 provides the required VME, VME extensions, and 2eSST functions. Transceivers are used to buffer the VME signals between the TSi148 and the VME backplane. Refer to the *TSi148 User's Manual* listed in [Appendix 9, Related Documentation](#), for additional details and/or programming information.

4.10.3 Serial ATA Host Controller

The SATA host controller uses the Silicon Image SiI3124A PCI-X to Serial ATA Controller. This device provides four SATA channels at 1.5Gb/s and is compliant with the *Serial ATA: High speed serialized AT Attachment Specification, Revision 1.0*. It also supports the native command queuing feature of SATA II.

The MVME3100 uses two of the four SATA channels. Channel 0 is routed to a SATA connector mounted on the front panel for an external drive connection. Channel 1 is routed to a planar SATA connector for an inside the chassis drive connection. Collocated with the planar connector is a SATA power connector.

The MVME3100 provides two programmable LEDs to indicate SATA channel activity.

Refer to the SiI3124A PCI-X to *Serial ATA Controller Data Sheet* listed in [Appendix 9, Related Documentation](#), for additional details and/or programming information

4.10.4 PCI-X-to-PCI-X Bridges

The MVME3100 uses two PLX PCI6520 PCI-X-to-PCI-X bridges to isolate the primary PCI bus, bus A. These bridges isolate bus A from bus B with the PMC sites and from bus C with the USB controller and PMCspan interface. The PCI6520 is a 64-bit, 133MHz, PCI-X r1.0b compliant device. It operates asynchronously between 33MHz and 133MHz on either primary or secondary port. Refer to the *PCI6520CB Data Book* listed in [Appendix 9, Related Documentation](#), for additional details and/or programming information.

4.10.5 PCI Mezzanine Card Slots

The MVME3100 provides two PMC sites that support standard PMCs or PrPMCs. Both PMC sites are located on PCI bus B and operate at the same speed and mode as determined by the slowest PMC module. The board routing supports a maximum of 100MHz PCI-X operation on each site. Signaling voltage (V_{io}) for the two PMC sites is dependent on keying pin installation options and can be configured for 5V or 3.3V. **Both sites must be configured for the same V_{io} voltage or the V_{io} voltage will be disabled.** Each PMC site has enough 3.3V and 5V power allocated to support a 25 watt (max) PMC or PrPMC from either supply.

PMC slot 1 supports:

Feature	Description
Mezzanine Type	PMC = PCI Mezzanine Card
Mezzanine Size	S1B = Single width and standard depth (75mm x 150mm) with front panel
PMC Connectors	J11, J12, J13, and J14 (32/64-bit PCI with front and rear I/O)
Signaling Voltage	VIO = +3.3V (+5V tolerant) or +5V, selected by keying pin

Functional Description

PMC slot 2 supports:

Feature	Description
Mezzanine Type	PMC = PCI Mezzanine Card
Mezzanine Size	S1B = Single width and standard depth (75mm x 150mm) with front panel
PMC Connectors	J21, J22, and J23 (32/64-bit PCI with front I/O)
Signaling Voltage	VIO = +3.3V (+5V tolerant) or +5V, selected by keying pin

You cannot use 3.3V and 5V PMCs together; the voltage keying pin on slots 1 and 2 must be identical. When in 5V mode, the bus runs at 33MHz.

In addition, the PMC connectors are located such that a double-width PMC may be installed in place of the two single-width PMCs.

In this case, the MVME3100 supports:

Feature	Description
Mezzanine Type	PMC = PCI Mezzanine Card
Mezzanine Size	Double width and standard depth (150mm x 150mm) with front panel
PMC Connectors	J11, J12, J13, J14, J21, J22, and J23 (32/64-bit PCI with front and rear I/O) on J14 only
Signaling Voltage	VIO = +3.3V (+5V tolerant) or +5V, selected by keying pin

On PMC site 1, the user I/O – J14 signals will only support the low-current, high-speed signals and are not to be used for any current bearing power supply usage. The maximum current rating of each pin/signal is 100mA.

4.10.6 USB

The USB 2.0 host controller provides USB ports with integrated transceivers for connectivity with any USB-compliant device or hub. USB channel 1 is routed to a single USB connector located at the front panel. DC power to the front panel USB port is supplied via a USB power switch, which provides soft-start, current limiting, over-current detection, and power enable for port 1. Refer to the *µPD720101 USB 2.0 Host Controller Data Sheet* listed in [Appendix 9, Related Documentation](#), for additional details.

4.10.7 PMC Expansion

The MVM3E3100 provides additional PMC module capability through the use of a connector on bus C that is compatible with the PMCspan boards. Up to four additional PMC modules may be added by using existing PMCspan boards. Refer to the *PMCspan PMC Adapter Carrier Board Installation and Use* manual listed in [Appendix 9, Related Documentation](#), for additional details.

4.11 General-Purpose Timers

There are a total of eight independent, 32-bit timers. Four timers are integrated into the MPC8540 and four timers are in the PLD. The four MPC8540 timers are clocked by the RTC input, which is driven by a 1MHz clock. The clock source for the four timers in the PLD is 25MHz. Refer to the *MPC8540 Reference Manual* listed in [Appendix 9, Related Documentation](#), for additional details and/or programming information.

4.12 Real-time Clock Battery

There is an on-board Renata SMT battery holder on the MVME3100. This SMTU2430-1 holder allows for quick and easy replacement of a 3V button cell lithium battery (CR2430), which provides back-up power to the on-board DS1375 RTC. A battery switching circuit provides automatic switching between the 3.3V and battery voltages. The battery provides backup power to the RTC for a minimum of one year at nominal temperature.

4.13 Reset Control Logic

The sources of reset on the MVME3100 are the following:

- Power-up
- Reset switch
- Watchdog timer
- System Control register bit
- VMEbus reset

A board-level hard reset generates a reset for the entire board including the MPC8540, local PCI/PCI-X buses, Ethernet PHYs, serial ports, flash devices, and PLD(s). If the MVME3100 is configured as the VME system controller, the VME bus and local TSi148 reset input are also reset.

4.14 Debug Support

The MVME3100 provides a boundary scan header for boundary scan test access and device programming. This board also provides a separate standard COP header for MPC8540 COP emulation.

Pin Assignments

5.1 Introduction

This chapter provides pin assignments for various connectors and headers on the MMVE3100 single board computer and the MVME721 transition module.

PMC Expansion Connector (J4)

Ethernet Connectors (GENET1/J41B, GENET2/J2B, ENET1/J2A)

PCI Mezzanine Card (PMC) Connectors (J11 – J14, J21 – J23)

Serial Port Connectors (COM1/J41A, COM2–COM5/J2A–D)

VMEbus P1 Connector

VMEbus P2 Connector

MVME721 PMC I/O Module (PIM) Connectors (J10, J14)

Planar SATA Power Connector (J30)

USB Connector (J27)

SATA Connectors (J28 and J29)

The following headers are described in this chapter:

Boundary Scan Header (J24)

Processor COP Header (J25)

5.2 Connectors

This section describes the pin assignments and signals for the connectors on the MVME3100.

5.2.1 PMC Expansion Connector (J4)

One 114-pin Mictor connector with a center row of power and ground pins is used to provide PCI expansion capability. The pin assignments for this connector are as follows:

Pin Assignments

Table 5-1 PMC Expansion Connector Pin Assignment

Pin	Signal		Signal	Pin
1	+3.3V		+3.3V	2
3	PCICLK		PMCINTA#	4
5	GND		PMCINTB#	6
7	PURST#		PMCINTC#	8
9	HRESET#		PMCINTD#	10
11	TDO		TDI	12
13	TMS		TCK	14
15	TRST#		PEP#	16
17	PCIXGNT#		PCIXREQ#	18
19	+12V	GND	-12V	20
21	PERR#		SERR#	22
23	LOCK#		No Connect	24
25	DEVSEL#		No Connect	26
27	GND		PCI XCAP	28
29	TRDY#		IRDY#	30
31	STOP#		FRAME#	32
33	GND		M66EN	34
35	ACK64#		No Connect	36
37	REQ64#		No Connect	38

Table 5-1 PMC Expansion Connector Pin Assignment (continued)

Pin	Signal		Signal	Pin
39	PAR		PCIRST#	40
41	C/BE1#		C/BE0#	42
43	C/BE3#		C/BE2#	44
45	AD1		AD0	46
47	AD3		AD2	48
49	AD5		AD4	50
51	AD7		AD6	52
53	AD9		AD8	54
55	AD11		AD10	56
57	AD13	+5V	AD12	58
59	AD15		AD14	60
61	AD17		AD16	62
63	AD19		AD18	64
65	AD21		AD20	66
67	AD23		AD22	68
69	AD25		AD24	70
71	AD27		AD26	72
73	AD29		AD28	74
75	AD31		AD30	76

Pin Assignments

Table 5-1 PMC Expansion Connector Pin Assignment (continued)

Pin	Signal		Signal	Pin
77	PAR64		No Connect	78
79	C/BE5#		C/BE4#	80
81	C/BE7#		C/BE6#	82
83	AD33		AD32	84
85	AD35		AD34	86
87	AD37		AD36	88
89	AD39		AD38	90
91	AD41		AD40	92
93	AD43		AD42	94
95	AD45	GND	AD44	96
97	AD47		AD46	98
99	AD49		AD48	100
101	AD51		AD50	102
103	AD53		AD52	104
105	AD55		AD54	106
107	AD57		AD56	108
109	AD59		AD58	110
111	AD61		AD60	112
113	AD63		AD62	114

All PMC expansion signals are shared with the USB controller.

5.2.2 Ethernet Connectors (GENET1/J41B, GENET2/J2B, ENET1/J2A)

There is one 10/100 and two 10/100/1000Mb/s full duplex Ethernet interfaces using the MPC8540 Fast Ethernet Controller (FEC) and two Triple Speed Ethernet Controllers (TSEC). One Gigabit Ethernet interface is routed to a front-panel RJ-45 connector with integrated LEDs for speed and activity indication. The other Gigabit Ethernet interface and the 10/100 interface are routed to P2 for rear I/O. The pin assignments for these connectors are as follows:

Table 5-2 Ethernet Connectors Pin Assignment

Pin #	Signal	1000 Mb/s	10/100 Mb/s
1	MDIO0+	_DA+	TD+
2	MDIO0-	_DA-	TD-
3	MDIO1+	_DB+	RD+
4	MDIO1-	_DC+	Not Used
5	MDIO2+	_DC-	Not Used
6	MDIO2-	_DB-	RD-
7	MDIO3+	_DD+	Not Used
8	MDIO3-	_DD-	Not Used

5.2.3 PCI Mezzanine Card (PMC) Connectors (J11 – J14, J21 – J23)

There are seven 64-pin SMT connectors on the MVME3100 to provide 32/64-bit PCI interfaces and P2 I/O for one optional add-on PMC.

PMC slot connector J14 contains the signals that go to VME P2 I/O rows A, C, D, and Z.

The pin assignments for these connectors are as follows.

Table 5-3 PMC Slot 1 Connector (J11) Pin Assignments

Pin	Signal	Signal	Pin
1	TCK	-12V	2
3	GND	INTA#	4
5	INTB#	INTC#	6

Pin Assignments

Table 5-3 PMC Slot 1 Connector (J11) Pin Assignments (continued)

Pin	Signal	Signal	Pin
7	PMCPRSNT1#	+5V	8
9	INTD#	PCI_RSVD	10
11	GND	+3.3Vaux	12
13	CLK	GND	14
15	GND	PMCGNT1#	16
17	PMCREQ1#	+5V	18
19	+3.3V (VIO)	AD31	20
21	AD28	AD27	22
23	AD25	GND	24
25	GND	C/BE3#	26
27	AD22	AD21	28
29	AD19	+5V	30
31	+3.3V (VIO)	AD17	32
33	FRAME#	GND	34
35	GND	IRDY#	36
37	DEVSEL#	+5V	38
39	GND	LOCK#	40
41	PCI_RSVD	PCI_RSVD	42
43	PAR	GND	44
45	+3.3V (VIO)	AD15	46
47	AD12	AD11	48
49	AD09	+5V	50
51	GND	C/BE0#	52
53	AD06	AD05	54

Table 5-3 PMC Slot 1 Connector (J11) Pin Assignments (continued)

Pin	Signal	Signal	Pin
55	AD04	GND	56
57	+3.3V (VIO)	AD03	58
59	AD02	AD01	60
61	AD00	+5V	62
63	GND	REQ64#	64

Table 5-4 PMC Slot 1 Connector (J12) Pin Assignments

Pin	Signal	Signal	Pin
1	+12V	TRST#	2
3	TMS	TDO	4
5	TDI	GND	6
7	GND	Not Used	8
9	Not Used	Not Used	10
11	Pull-up	+3.3V	12
13	RST#	Pull-down	14
15	+3.3V	Pull-down	16
17	Not Used	GND	18
19	AD30	AD29	20
21	GND	AD26	22
23	AD24	+3.3V	24
25	IDSEL1	AD23	26
27	+3.3V	AD20	28
29	AD18	GND	30
31	AD16	C/BE2#	32

Pin Assignments

Table 5-4 PMC Slot 1 Connector (J12) Pin Assignments (continued)

Pin	Signal	Signal	Pin
33	GND	IDSEL1B	34
35	TRDY#	+3.3V	36
37	GND	STOP#	38
39	PERR#	GND	40
41	+3.3V	SERR#	42
43	C/BE1#	GND	44
45	AD14	AD13	46
47	M66EN	AD10	48
49	AD08	+3.3V	50
51	AD07	REQ1B#	52
53	+3.3V	GNT1B#	54
55	Not Used	GND	56
57	Not Used	EREADY0	58
59	GND	Not Used	60
61	ACK64#	+3.3V	62
63	GND	No Connect (MONARCH#)	64

Table 5-5 PMC Slot 1 Connector (J13) Pin Assignments

Pin	Signal	Signal	Pin
1	Reserved	GND	2
3	GND	C/BE7#	4
5	C/BE6#	C/BE5#	6
7	C/BE4#	GND	8
9	+3.3V (VIO)	PAR64	10

Table 5-5 PMC Slot 1 Connector (J13) Pin Assignments (continued)

Pin	Signal	Signal	Pin
11	AD63	AD62	12
13	AD61	GND	14
15	GND	AD60	16
17	AD59	AD58	18
19	AD57	GND	20
21	+3.3V (VIO)	AD56	22
23	AD55	AD54	24
25	AD53	GND	26
27	GND	AD52	28
29	AD51	AD50	30
31	AD49	GND	32
33	GND	AD48	34
35	AD47	AD46	36
37	AD45	GND	38
39	+3.3V (VIO)	AD44	40
41	AD43	AD42	42
43	AD41	GND	44
45	GND	AD40	46
47	AD39	AD38	48
49	AD37	GND	50
51	GND	AD36	52
53	AD35	AD34	54
55	AD33	GND	56

Pin Assignments

Table 5-5 PMC Slot 1 Connector (J13) Pin Assignments (continued)

Pin	Signal	Signal	Pin
57	+3.3V (VIO)	AD32	58
59	Reserved	Reserved	60
61	Reserved	GND	62
63	GND	Reserved	64

Table 5-6 PMC Slot 1 Connector (J14) Pin Assignments

Pin	Signal	Signal	Pin
1	PMC1_1 (P2-C1)	PMC1_2 (P2-A1)	2
3	PMC1_3 (P2-C2)	PMC1_4 (P2-A2)	4
5	PMC1_5 (P2-C3)	PMC1_6 (P2-A3)	6
7	PMC1_7 (P2-C4)	PMC1_8 (P2-A4)	8
9	PMC1_9 (P2-C5)	PMC1_10 (P2-A5)	10
11	PMC1_11 (P2-C6)	PMC1_12 (P2-A6)	12
13	PMC1_13 (P2-C7)	PMC1_14 (P2-A7)	14
15	PMC1_15 (P2-C8)	PMC1_16 (P2-A8)	16
17	PMC1_17 (P2-C9)	PMC1_18 (P2-A9)	18
19	PMC1_19 (P2-C10)	PMC1_20 (P2-A10)	20
21	PMC1_21 (P2-C11)	PMC1_22 (P2-A11)	22
23	PMC1_23 (P2-C12)	PMC1_24 (P2-A12)	24
25	PMC1_25 (P2-C13)	PMC1_26 (P2-A13)	26
27	PMC1_27 (P2-C14)	PMC1_28 (P2-A14)	28
29	PMC1_29 (P2-C15)	PMC1_30 (P2-A15)	30
31	PMC1_31 (P2-C16)	PMC1_32 (P2-A16)	32
33	PMC1_33 (P2-C17)	PMC1_34 (P2-A17)	34

Table 5-6 *PMC Slot 1 Connector (J14) Pin Assignments (continued)*

Pin	Signal	Signal	Pin
35	PMC1_35 (P2-C18)	PMC1_36 (P2-A18)	36
37	PMC1_37 (P2-C19)	PMC1_38 (P2-A19)	38
39	PMC1_39 (P2-C20)	PMC1_40 (P2-A20)	40
41	PMC1_41 (P2-C21)	PMC1_42 (P2-A21)	42
43	PMC1_43 (P2-C22)	PMC1_44 (P2-A22)	44
45	PMC1_45 (P2-C23)	PMC1_46 (P2-A23)	46
47	PMC1_47 (P2-C24)	PMC1_48 (P2-A24)	48
49	PMC1_49 (P2-C25)	PMC1_50 (P2-A25)	50
51	PMC1_51 (P2-C26)	PMC1_52 (P2-A26)	52
53	PMC1_53 (P2-C27)	PMC1_54 (P2-A27)	54
55	PMC1_55 (P2-C28)	PMC1_56 (P2-A28)	56
57	PMC1_57 (P2-C29)	PMC1_58 (P2-A29)	58
59	PMC1_59 (P2-C30)	PMC1_60 (P2-A30)	60
61	PMC1_61 (P2-C31)	PMC1_62 (P2-A31)	62
63	PMC1_63 (P2-C32)	PMC1_64 (P2-A32)	64

Table 5-7 *PMC Slot 2 Connector (J21) Pin Assignments*

Pin	Signal	Signal	Pin
1	TCK	-12V	2
3	GND	INTC#	4
5	INTD#	INTA#	6
7	PMCPRSNT1#	+5V	8
9	INTB#	PCI_RSVD	10
11	GND	+3.3Vaux	12

Pin Assignments

Table 5-7 PMC Slot 2 Connector (J21) Pin Assignments (continued)

Pin	Signal	Signal	Pin
13	CLK	GND	14
15	GND	PMCGNT1#	16
17	PMCREQ1#	+5V	18
19	+3.3V (VIO)	AD31	20
21	AD28	AD27	22
23	AD25	GND	24
25	GND	C/BE3#	26
27	AD22	AD21	28
29	AD19	+5V	30
31	+3.3V (VIO)	AD17	32
33	FRAME#	GND	34
35	GND	IRDY#	36
37	DEVSEL#	+5V	38
39	GND	LOCK#	40
41	PCI_RSVD	PCI_RSVD	42
43	PAR	GND	44
45	+3.3V (VIO)	AD15	46
47	AD12	AD11	48
49	AD09	+5V	50
51	GND	C/BE0#	52
53	AD06	AD05	54
55	AD04	GND	56
57	+3.3V (VIO)	AD03	58
59	AD02	AD01	60

Table 5-7 PMC Slot 2 Connector (J21) Pin Assignments (continued)

Pin	Signal	Signal	Pin
61	AD00	+5V	62
63	GND	REQ64#	64

Table 5-8 PMC Slot 2 Connector (J22) Pin Assignments

Pin	Signal	Signal	Pin
1	+12V	TRST#	2
3	TMS	TDO	4
5	TDI	GND	6
7	GND	Not Used	8
9	Not Used	Not Used	10
11	Pull-up	+3.3V	12
13	RST#	Pull-down	14
15	+3.3V	Pull-down	16
17	Not Used	GND	18
19	AD30	AD29	20
21	GND	AD26	22
23	AD24	+3.3V	24
25	IDSEL1	AD23	26
27	+3.3V	AD20	28
29	AD18	GND	30
31	AD16	C/BE2#	32
33	GND	IDSEL1B	34
35	TRDY#	+3.3V	36
37	GND	STOP#	38

Pin Assignments

Table 5-8 PMC Slot 2 Connector (J22) Pin Assignments (continued)

Pin	Signal	Signal	Pin
39	PERR#	GND	40
41	+3.3V	SERR#	42
43	C/BE1#	GND	44
45	AD14	AD13	46
47	M66EN	AD10	48
49	AD08	+3.3V	50
51	AD07	REQ1B#	52
53	+3.3V	GNT1B#	54
55	Not Used	GND	56
57	Not Used	EREADY1	58
59	GND	Not Used	60
61	ACK64#	+3.3V	62
63	GND	No Connect (MONARCH#)	64

Table 5-9 PMC Slot 2 Connector (J23) Pin Assignments

Pin	Signal	Signal	Pin
1	Reserved	GND	2
3	GND	C/BE7#	4
5	C/BE6#	C/BE5#	6
7	C/BE4#	GND	8
9	+3.3V (VIO)	PAR64	10
11	AD63	AD62	12
13	AD61	GND	14
15	GND	AD60	16
17	AD59	AD58	18

Table 5-9 PMC Slot 2 Connector (J23) Pin Assignments (continued)

Pin	Signal	Signal	Pin
19	AD57	GND	20
21	+3.3V (VIO)	AD56	22
23	AD55	AD54	24
25	AD53	GND	26
27	GND	AD52	28
29	AD51	AD50	30
31	AD49	GND	32
33	GND	AD48	34
35	AD47	AD46	36
37	AD45	GND	38
39	+3.3V (VIO)	AD44	40
41	AD43	AD42	42
43	AD41	GND	44
45	GND	AD40	46
47	AD39	AD38	48
49	AD37	GND	50
51	GND	AD36	52
53	AD35	AD34	54
55	AD33	GND	56
57	+3.3V (VIO)	AD32	58
59	Reserved	Reserved	60
61	Reserved	GND	62
63	GND	Reserved	64

Pin Assignments

5.2.4 Serial Port Connectors (COM1/J41A, COM2–COM5/J2A-D)

There is one front access asynchronous serial port interface (SP0) that is routed to the RJ-45 front-panel connector. There are four asynchronous serial port interfaces, SP1 – SP4, which are routed to the P2 connector. The pin assignments for these connectors are as follows:

Table 5-10 COM Port Connector Pin Assignments

Pin	Signal
1	No connect
2	RTS
3	GND
4	TX
5	RX
6	GND
7	CTS
8	No connect

5.2.5 VMEbus P1 Connector

The VME P1 connector is a 160-pin DIN. The P1 connector provides power and VME signals for 24-bit address and 16-bit data. The pin assignments for the P1 connector is as follows:

Table 5-11 VMEbus P1 Connector Pin Assignments

Pin	ROW Z	ROW A	ROW B	ROW C	ROW D
1	Reserved	D00	BBSY*	D08	+5V
2	GND	D01	BCLR*	D09	GND
3	Reserved	D02	ACFAIL*	D10	Reserved
4	GND	D03	BG0IN*	D11	Reserved
5	Reserved	D04	BG0OUT*	D12	Reserved
6	GND	D05	BG1IN*	D13	Reserved

Table 5-11 VMEbus P1 Connector Pin Assignments (continued)

Pin	ROW Z	ROW A	ROW B	ROW C	ROW D
7	Reserved	D06	BG1OUT*	D14	Reserved
8	GND	D07	BG2IN*	D15	Reserved
9	Reserved	GND	BG2OUT*	GND	GAP_L
10	GND	SYSCLK	BG3IN*	SYSFAIL*	GA0_L
11	Reserved	GND	BG3OUT*	BERR*	GA1_L
12	GND	DS1*	BR0*	SYSRESET*	Reserved
13	Reserved	DS0*	BR1*	LWORD*	GA2_L
14	GND	WRITE*	BR2*	AM5	Reserved
15	Reserved	GND	BR3*	A23	GA3_L
16	GND	DTACK*	AM0	A22	Reserved
17	Reserved	GND	AM1	A21	GA4_L
18	GND	AS*	AM2	A20	Reserved
19	Reserved	GND	AM3	A19	Reserved
20	GND	IACK*	GND	A18	Reserved
21	Reserved	IACKIN*	SERA	A17	Reserved
22	GND	IACKOUT*	SERB	A16	Reserved
23	Reserved	AM4	GND	A15	Reserved
24	GND	A07	IRQ7*	A14	Reserved
25	Reserved	A06	IRQ6*	A13	Reserved
26	GND	A05	IRQ5*	A12	Reserved
27	Reserved	A04	IRQ4*	A11	Reserved
28	GND	A03	IRQ3*	A10	Reserved
29	Reserved	A02	IRQ2*	A09	Reserved

Pin Assignments

Table 5-11 VMEbus P1 Connector Pin Assignments (continued)

Pin	ROW Z	ROW A	ROW B	ROW C	ROW D
30	GND	A01	IRQ1*	A08	Reserved
31	Reserved	-12V	+5VSTDBY	+12V	GND
32	GND	+5V	+5V	+5V	+5V

5.2.6 VMEbus P2 Connector

The VME P2 connector is a 160-pin DIN. Row B of the P2 connector provides power to the MVME3100 and to the upper eight VMEbus address lines and additional 16 VMEbus data lines. The pin assignments for the P2 connector are the same for both the MVME3100 and MVME721, and are as follows:

Table 5-12 VME P2 Connector Pinout

Pin	P2-Z	P2-A	P2-B	P2-C	P2-D
1	SP1RX	PMC1_IO2	+5V	PMC1_IO1	E1-1+
2	GND	PMC1_IO4	GND	PMC1_IO3	E1-1-
3	SPITX	PMC1_IO6	VRETRY_L	PMC1_IO5	GND
4	GND	PMC1_IO8	VA24	PMC1_IO7	E1-2+
5	SP1CTS	PMC1_IO10	VA25	PMC1_IO9	E1-2-
6	GND	PMC1_IO12	VA26	PMC1_IO11	GND
7	SP1RTS	PMC1_IO14	VA27	PMC1_IO13	NC
8	GND	PMC1_IO16	VA28	PMC1_IO15	NC
9	SP2RX	PMC1_IO18	VA29	PMC1_IO17	GND
10	GND	PMC1_IO20	VA30	PMC1_IO19	NC
11	SP2TX	PMC1_IO22	VA31	PMC1_IO21	NC
12	GND	PMC1_IO24	GND	PMC1_IO23	GND
13	SP2CTS	PMC1_IO26	+5V	PMC1_IO25	I2C_SDA
14	GND	PMC1_IO28	VD16	PMC1_IO27	I2C_SCL

Table 5-12 VME P2 Connector Pinout (continued)

Pin	P2-Z	P2-A	P2-B	P2-C	P2-D
15	SP2RTS	PMC1_IO30	VD17	PMC1_IO29	E1_LINK
16	GND	PMC1_IO32	VD18	PMC1_IO31	E1_ACT
17	SP3RX	PMC1_IO34	VD19	PMC1_IO33	E2_LINK
18	GND	PMC1_IO36	VD20	PMC1_IO35	E2_ACT
19	SP3TX	PMC1_IO38	VD21	PMC1_IO37	GND
20	GND	PMC1_IO40	VD22	PMC1_IO39	E2-4-
21	SP3CTS	PMC1_IO42	VD23	PMC1_IO41	E2-4+
22	GND	PMC1_IO44	GND	PMC1_IO43	GND
23	SP3RTS	PMC1_IO46	VD24	PMC1_IO45	E2-3-
24	GND	PMC1_IO48	VD25	PMC1_IO47	E2-3+
25	SP4RX	PMC1_IO50	VD26	PMC1_IO49	GND
26	GND	PMC1_IO52	VD27	PMC1_IO51	E2-2-
27	SP4TX	PMC1_IO54	VD28	PMC1_IO53	E2-2+
28	GND	PMC1_IO56	VD29	PMC1_IO55	GND
29	SP4CTS	PMC1_IO58	VD30	PMC1_IO57	E2-1-
30	GND	PMC1_IO60	VD31	PMC1_IO59	E2-1+
31	SP4RTS	PMC1_IO62	GND	PMC1_IO61	GND
32	GND	PMC1_IO64	+5V	PMC1_IO63	+5V

Pin Assignments

5.2.7 MVME721 PMC I/O Module (PIM) Connectors (J10, J14)

PMC Host I/O connector J10 routes only power and ground from VME P2. There are no Host I/O signals on this connector. The MVME3100 routes PMC I/O from J14 of PMC Slot 1 to VME P2 rows A and C. The MVME721 routes these signals (pin-for-pin) from VME P2 to PMC I/O Module connector J14. See [Table 5-13](#) and [Table 5-6](#) for the pin assignments.

Table 5-13 MVME721 Host I/O Connector (J10) Pin Assignments

Pin	Signal	Signal	Pin
1	No Connect	No Connect	2
3	No Connect	No Connect	4
5	+5V	No Connect	6
7	No Connect	No Connect	8
9	No Connect	+3.3V	10
11	No Connect	No Connect	12
13	GND	No Connect	14
15	No Connect	No Connect	16
17	No Connect	GND	18
19	No Connect	No Connect	20
21	+5V	No Connect	22
23	No Connect	No Connect	24
25	No Connect	+3.3V	26
27	No Connect	No Connect	28
29	GND	No Connect	30
31	No Connect	No Connect	32
33	No Connect	GND	34
35	No Connect	No Connect	36
37	+5V	No Connect	38
39	No Connect	No Connect	40

Table 5-13 MVME721 Host I/O Connector (J10) Pin Assignments (continued)

Pin	Signal	Signal	Pin
41	No Connect	+3.3V	42
43	No Connect	No Connect	44
45	GND	No Connect	46
47	No Connect	No Connect	48
49	No Connect	GND	50
51	No Connect	No Connect	52
53	+5V	No Connect	54
55	No Connect	No Connect	56
57	No Connect	+3.3V	58
59	No Connect	No Connect	60
61	No Connect	No Connect	62
63	No Connect	No Connect	64

5.2.8 Planar SATA Power Connector (J30)

There is one 2mm pitch header installed as a planar header on the MVME3100 board to provide power to a serial ATA (SATA) drive mounted on the board or somewhere within the chassis. The pin assignments for this header are as follows:

Table 5-14 Planar ATA Power Connector (J30) Pin Assignments

Pin	Signal
1	+5V
2	+5V
3	GND
4	GND

Pin Assignments

5.2.9 USB Connector (J27)

There is one USB Type A connector located on the MVME3100 front panel. The pin assignments are as follows:

Table 5-15 USB Connector (J27) Pin Assignments

Pin	Signal
1	USB_VBUS (+5.0V)
2	USB_DATA-
3	USB_DATA+
4	GND

5.2.10 SATA Connectors (J28 and J29)

The MVME3100 has two SATA connectors. J28 is an internal type SATA connector located on the planar and is intended to connect to a drive located on the board or somewhere inside the chassis. J29 is an external type SATA connected located on the front panel and is intended to connect to an external SATA drive. The pin assignment for these connectors is as follows:

Table 5-16 SATA Connectors (J28 and J29) Pin Assignments

Pin	Signal
1	GND
2	SATA_TX+
3	SATA_TX-
4	GND
5	SATA_RX-
6	SATA_RX+
7	GND

5.3 Headers

This section describes the pin assignments of the Headers on the MVME3100. For Header settings, refer to [Configuring Hardware on page 28](#).

5.3.1 Boundary Scan Header (J24)

The 14-pin boundary scan header provides an interface for programming the on-board PLDs and for boundary scan testing/debug purposes. The pin assignments for this header are as follows:

Table 5-17 Boundary Scan Header (J24) Pin Assignments

Pin	Signal	Signal	Pin
1	TRST_L	GND	2
3	TDO	GND	4
5	TDI	GND	6
7	TMS	GND	8
9	TCK	GND	10
11	NC	GND (BSCANEN_L)	12 ¹
13	BSCAN_AW_L	GND	14

1. Pin 12 must be grounded in the cable in order to enable boundary scan.

5.3.2 Processor COP Header (J25)

There is one standard 16-pin header that provides access to the COP function. The pin assignments for this header are as follows:

Table 5-18 Processor COP Header (J25) Pin Assignments

Pin	Signal	Signal	Pin
1	CPU_TDO	No Connect	2
3	CPU_TDI	CPU_TRST_L	4
5	Pull-up	CPU_VIO (+3.3V)	6 ¹
7	CPU_TCK	CPU_CKSTPI_L	8

Pin Assignments

Table 5-18 Processor COP Header (J25) Pin Assignments (continued)

Pin	Signal	Signal	Pin
9	CPU_TMS	No Connect	10
11	CPU_SRST_L	GND (optional pull-down)	12
13	CPU_HRST_L	KEY (no pin)	14
15	CPU_CKSTPO_L	GND	16

1. Pin 6 +3.3V has a resettable fuse and can supply up to 0.5A to power I/O buffers in the COP controller.

Memory Maps

6.1 Introduction

This chapter provides information on memory maps and system and configuration registers

6.2 Memory Maps

Memory Maps is explained in two different types:

- The mapping of all resources as viewed by local bus masters (local bus memory map)
- The mapping of on-board resources as viewed by VMEbus Masters (VMEbus memory map)

6.2.1 Default Processor Memory Map

The MPC8540 presents a default processor memory map following RESET negation. The following table shows the default memory map from the point of view of the processor. The e500 core only provides one default TLB entry to access boot code and it allows for accesses within the highest 4KB of memory. To access the full 8MB of default boot space (and the 1MB of CCSR space), additional TLB entries must be set up within the e500 core for mapping these regions. Refer to the *MPC8540 Reference Manual* listed in [Appendix 9, Related Documentation](#) for details.

This is the default location for the CCSRs, but it is not mapped after reset.

Table 6-1 Default Processor Address Map

Processor Address		Size	Definition	Notes
Start	End			
0000 0000	FF6F FFFF	4087M	Not mapped	
FF70 0000	FF7F FFFF	1M	MPC8540 CCS Registers	1
FF80 0000	FFFF FFFF	8M	Flash	2

Only FFFF F000 to FFFF FFFF is mapped after reset. The e500 core fetches the first instruction from FFFF FFFC following a reset.

Memory Maps

6.2.2 MOTLoad's Processor Memory Map

MOTLoad's processor memory map is given in the following table.

Table 6-2 MOTLoad's Processor Address Map

Processor Address		Size	Definition	Notes
Start	End			
0000 0000	top_dram-1	dram_size (2GB max)	System Memory (on-board DRAM)	
8000 0000	DFFF FFFF	1.5GB	PCI Memory Space/VME	
E000 0000	E0FF FFFF	16MB	PCI I/O Space	
E100 0000	E10F FFFF	1MB	MPC8540 CCSR	
E1100 0000	E1FF FFFF	15MB	Not Used	
E200 0000	E2FF FFFF	16MB	Status/Control Registers/UARTs, External Timers	
E300 0000	FFFF FFFF	208MB	Not Used	
F000 0000	F7FF FFFF	128MB	Reserved	1, 2
bottom_flash	FFFF FFFF	flash_size (128MB max)	Flash	2

1. Reserved for future larger flash devices.

2. The flash is logically one bank but may be physically implemented in two banks.

After RESET, the MPC8540 does not map any PCI memory space (inbound or outbound), and does not respond to Config cycles.

6.2.3 VME Memory Map

The MVME3100 is fully capable of supporting both the PReP and the CHRP VME Memory Map examples with RAM size limited to 2GB.

6.2.4 System I/O Memory Map

System resources including System Control and Status registers, external timers, and the QUART are mapped into a 16MB address range from the MVME3100 via the MPC8540 local bus controller (LBC). The memory map is defined in the following table, including the LBC bank chip select used to decode the register:

Table 6-3 System I/O Memory Map

Address	Definition	LBC Bank / Chip Select	Notes
E200 0000	System Status Register	2	3
E200 0001	System Control Register	2	3
E200 0002	Status Indicator Register	2	3
E200 0003	Flash Control/Status Register	2	3
E200 0004	PCI Bus A Status Register	2	3
E200 0005	PCI Bus B Status Register	2	3
E200 0006	PCI Bus C Status Register	2	3
E200 0007	Interrupt Detect Register	2	3
E200 0008	Presence Detect Register	2	3
E200 0009	PLD Revision	2	3
E200 000C	PLD Date Code (32 bits)	2	3
E200 0010	Test Register 1 (32 bits)	2	3
E200 0014	Test Register 2 (32 bits)	2	3 ¹
E200 0018 - E200 0FFF	Reserved		1
E201 1000 - E201 1FFF	COM 2 (QUART channel 1)	3	
E201 2000 - E201 2FFF	COM 3 (QUART channel 2)	3	
E201 3000 - E201 3FFF	COM 4 (QUART channel 3)	3	

Memory Maps

Table 6-3 System I/O Memory Map (continued)

Address	Definition	LBC Bank / Chip Select	Notes
E201 4000 - E201 4FFF	COM 5 (QUART channel 4)	3	
E201 5000 - E201 FFFF	Reserved		1
E202 0000	External PLD Tick Timer Prescaler Register	4	2 ²
E202 0010	External PLD Tick Timer 1 Control Register	4	2
E202 0014	External PLD Tick Timer 1 Compare Register	4	2
E202 0018	External PLD Tick Timer 1 Counter Register	4	2
E202 001C	Reserved	4	2
E202 0020	External PLD Tick Timer 2 Control Register	4	2
E202 0024	External PLD Tick Timer 2 Compare Register	4	2
E202 0028	External PLD Tick Timer 2 Counter Register	4	2
E202 002C	Reserved	4	2
E202 0030	External PLD Tick Timer 3 Control Register	4	2
E202 0034	External PLD Tick Timer 3 Compare Register	4	2
E202 0038	External PLD Tick Timer 3 Counter Register	4	2
E202 003C	Reserved	4	2
E202 0040	External PLD Tick Timer 4 Control Register	4	2
E202 0044	External PLD Tick Timer 4 Compare Register	4	2
E202 0048	External PLD Tick Timer 4 Counter Register	4	2
E202 004C - E2FF FFFF	Reserved		1 ³

1. Byte read/write capable

2. 32-bit write only.

3. Reserved for future implementation.

6.2.5 System Status Register

The MVME3100 board System Status register is a read-only register used to provide board status information.

Table 6-4 System Status Register

REG	System Status Register – 0xE2000000							
BIT	7	6	5	4	3	2	1	0
FIELD	RSVD	RSVD	RSVD	SAFE_START	ABORT	RSVD	BD_TYPE	
OPER	R							
RESET	0	0	0	X	0	0	0	0

BD_TYPE

Board type. These bits indicate the board type.

- 00: VME SBC
- 01: PrPMC
- 10-11: Reserved

ABORT

This bit reflects the current state of the on-board abort signal. This is a debounced version of the abort switch and may be used to determine the state of the abort switch. A cleared condition indicates the abort switch is not depressed, while a set condition indicates the abort switch is asserted.

SAFE_START

ENV safe start. This bit reflects the current state of the ENV safe start select switch. A set condition indicates that firmware should use the safe ENV settings. A cleared condition indicates that the ENV settings programmed in NVRAM should be used by the firmware.

RSVD

Reserved for future implementation.

Memory Maps

6.2.6 System Control Register

The MVME3100 board System Control register provides board control bits.

Table 6-5 System Control Register

REG	System Control Register - 0xE200001							
BIT	7	6	5	4	3	2	1	0
FIELD	BD_RESET			RSVD	RSVD	RSVD	EEPROM_WP	TSTAT_MASK
OPER	R/W			R	R	R	R/W	R/W
RESET	0	0	0	0	0	X	1	1

TSTAT_MASK

Thermostat mask. This bit masks the DS1621 temperature sensor thermostat output. If this bit is cleared, the thermostat output is enabled to generate an interrupt. If the bit is set, the thermostat output is disabled from generating an interrupt.

EEPROM_WPEEPROM

Write protect. This bit provides protection against inadvertent writes to the on-board EEPROM devices. Clearing this bit enables writes to the EEPROM devices. Setting this bit write protects the devices. The devices are write protected following a reset.

BRD_RST

Board reset. These bits force a hard reset of the board. If a pattern is written in bits 5-7 where bit 7 is set, bit 6 is cleared, and bit 5 is set (101), a hard reset is generated. Any other pattern written in bits 5-7, does not generate a hard reset. These bits are cleared automatically when the board reset has been completed. These bits are always cleared during a read.

RSVD

Reserved for future implementation.

6.2.7 System Indicator Register

The MVME3100 board provides a System Indicator register that may be read by the system software to determine the state of the on-board status indicator LEDs or written to by system software to illuminate the corresponding on-board LEDs.

Table 6-6 System Indicator Register

REG	System Indicator Register - 0xE2000002							
BIT	7	6	5	4	3	2	1	0
FIELD	RSVD	RSVD	RSVD	RSVD	USR3	USR2	USR1	BRD_FAIL
OPER	R	R	R	R	R/W	R/W	R/W	R/W
RESET	0	0	0	0	0	0	0	1

BRD_FAIL

Board fail. This bit controls the board fail LED located on the front panel. A set condition illuminates the front-panel LED and a cleared condition extinguishes the front-panel LED.

USR1_LED

User LED 1. This bit controls the USR1 LED located on the front panel. A set condition illuminates the front-panel LED and a cleared condition extinguishes the front-panel LED.

USR2_LED

User LED 2. This bit controls the planar USR2 LED. A set condition illuminates the LED and a cleared condition extinguishes the LED.

USR3_LED

User LED 3. This bit controls the planar USR3 LED. A set condition illuminates the LED and a cleared condition extinguishes the LED.

RSVD

Reserved for future implementation.

Memory Maps

6.2.8 Flash Control/Status Register

The MVME3100 provides software-controlled bank write protect and map select functions as well as boot block select, bank write protect, and activity status for the flash.

Table 6-7 Flash Control/Status Register

REG	Flash Control/Status Register - 0xE2000003							
BIT	7	6	5	4	3	2	1	0
FIELD	RSVD	RSVD	RSVD	MAP_SEL	F_WP_SW	F_WP_HW	FBT_BLK_SEL	FLASH_RDY
OPER	R	R	R	R/W	R/W	R	R	R
RESET	0	0	0	0	1	X	X	1

FLASH_RDY

Flash ready. This bit provides the current state of the flash devices' Ready/Busy# pins. These open drain output pins from each flash device are wire OR'd to form Flash Ready.

FBT_BLK_SEL

Flash boot block select. This bit reflects the current state of the BOOT BLOCK B SELECT switch. A cleared condition indicates that boot block A is selected and mapped to the highest address. A set condition indicates that boot block B is selected and mapped to the highest address.

F_WP_HW

Hardware flash bank write protect switch status. This bit reflects the current state of the FLASH BANK WP switch. A set condition indicates that the entire flash bank is write protected. A cleared condition indicates that the flash bank is not write protected.

F_WP_SW

Software flash bank write protect. This bit provides software-controlled protection against inadvertent writes to the flash memory devices. A set condition indicates that the entire flash is write-protected. A cleared condition indicates that the flash bank is not write-protected, only when the hardware write-protect bit is also not set. This bit is set during reset and must be cleared by the system software to enable writing of the flash devices.

MAP_SEL

Memory map select. When this bit is cleared, the flash memory map is controlled by the Flash Boot Block Select switch. When the map select bit is set, boot block A is selected and mapped to the highest address.

RSVD

Reserved for future implementation.

6.2.9 PCI Bus Status Registers

The PCI Bus Status registers provide PCI bus configuration information for each of the PCI buses.

Table 6-8 PCI Bus A Status Register

REG	PCI Bus A Status Register - 0xE2000004							
BIT	7	6	5	4	3	2	1	0
FIELD	RSVD	RSVD	RSVD	RSVD	PCI_A_64B	PCIX_A	PCI_A_SPD	
OPER	R	R	R	R	R	R	R	R
RESET	0	0	0	0	1	X	0	1

PCI_A_SPD

PCI bus A speed. Indicates the frequency of PCI bus A.

- 00: 33MHz
- 01: 66MHz
- 10: 100MHz
- 11: 133MHz

PCIX_A

PCI-X bus A. A set condition indicates that bus A is operating in PCI-X mode. A cleared condition indicates PCI mode.

PCI_A_64B

PCI bus A 64-bit. A set condition indicates that bus A is enabled to operate in 64-bit mode. A cleared condition indicates 32-bit mode.

RSVD

Memory Maps

Reserved for future implementation.

Table 6-9 PCI Bus B Status Register

REG	PCI Bus B Status Register - 0xE2000005							
BIT	7	6	5	4	3	2	1	0
FIELD	3.3V_VIO	5.0V_VIO	ERDY2	ERDY1	PCI_B_64B	PCIX_B	PCI_B_SPD	
OPER	R	R	R	R	R	R	R	R
RESET	X	X	X	0	1	X	X	X

PCI_B_SPD

PCI bus B speed. Indicates the frequency of PCI bus B.

00: 33MHz

01: 66MHz

10: 100MHz

11: 133MHz

PCIX_B

PCI-X bus B. A set condition indicates that bus B is operating in PCI-X mode. A cleared condition indicates PCI mode.

PCI_B_64B

PCI bus B 64-bit. A set condition indicates that bus B is enabled to operate in 64-bit mode. A cleared condition indicates 32-bit mode.

ERDY1

EREDY1. Indicates that the PrPMC module installed in PMC site 1 is ready for enumeration when set. If cleared, the PrPMC module is not ready for enumeration. If no PrPMC is installed, this bit is always set.

ERDY2

EREDY2. Indicates that the PrPMC module installed in PMC site 2 is ready for enumeration when set. If cleared, the PrPMC module is not ready for enumeration. If no PrPMC is installed, the bit is always set.

5.0V_VIO

5.0V VIO Enabled. This bit set indicates that the PMC bus (PCI bus B) is configured for 5.0V VIO.

3.3V_VIO

3.3V VIO enabled. This bit set indicates that the PMC bus (PCI bus B) is configured to 3.3V VIO.

Table 6-10 PCI Bus C Status Register

REG	PCI Bus C Status Register - 0xE2000006							
BIT	7	6	5	4	3	2	1	0
FIELD	RSVD	RSVD	RSVD	RSVD	PCI_C_64B	PCIX_C		PCI_C_SPD
OPER	R	R	R	R	R	R	R	R
RESET	X	X	X	0	1	X	X	X

PCI_C_SPD

PCI bus C speed. Indicates the frequency of PCI bus C.

- 00: 33MHz
- 01: 66MHz
- 10: 100MHz
- 11: 133MHz

PCIX_C

PCI-X bus C. A set condition indicates that bus C is operating in PCI-X mode. A cleared condition indicates PCI mode.

PCI_C_64B

PCI bus C 64-bit. A set condition indicates that bus C is enabled to operate in 64-bit mode. A cleared condition indicates 32-bit mode.

RSVD

Reserved for future implementation.

6.2.10 Interrupt Detect Register

The MVME3100 provides an Interrupt Detect register that may be read by the system software to determine which of the Ethernet PHYs originated their combined (OR'd) interrupt.

Table 6-11 Interrupt Detect Register

REG	Interrupt Detect Register - 0xE200007							
BIT	7	6	5	4	3	2	1	0
FIELD	RSVD	RSVD	RSVD	RSVD	RSVD	FEC_PHY	TSEC2_PHY	TSEC1_PHY
OPER	R	R	R	R	R	R	R	R
RESET	1	1	1	0	0	0	0	0

TSEC1_PHY

TSEC1 PHY interrupt. If cleared, the TSEC1 interrupt is not asserted. If set, the TSEC1 interrupt is asserted.

TSEC2_PHY

TSEC2 PHY interrupt. If cleared, the TSEC2 interrupt is not asserted. If set, the TSEC2 interrupt is asserted.

FEC_PHY

FEC PHY interrupt. If cleared, the FEC interrupt is not asserted. If set, the FEC interrupt is asserted.

RSVD

Reserved for future implementation.

6.2.11 Presence Detect Register

The MVME3100 provides a Presence Detect register that may be read by the system software to determine the presence of optional devices.

Table 6-12 Presence Detect Register

REG	Presence Detect Register - 0xE2000008							
BIT	7	6	5	4	3	2	1	0
FIELD	RSVD	RSVD	RSVD	RSVD	RSVD	PEP	PMC2P	PMC1P
OPER	R	R	R	R	R	R	R	R
RESET	0	0	0	0	0	X	X	X

PMC1P

PMC module 1 present. If cleared, there is no PMC module installed in site 1. If set, the PMC module is installed.

PMC2P

PMC module 2 present. If cleared, there is no PMC module installed in site 2. If set, the PMC module is installed.

PEP

PMCspan present. If cleared, there is no PMCspan module installed. If set, the PMCspan module is installed.

RSVD

Reserved for future implementation.

Memory Maps

6.2.12 PLD Revision Register

The MVME3100 provides a PLD Revision register that may be read by the system software to determine the current revision of the timers/registers PLD.

Table 6-13 PLD Revision Register

REG	PLD Revision Register - 0xE2000009							
BIT	7	6	5	4	3	2	1	0
FIELD	PLD_REV							
OPER	R							
RESET	01							

PLD_REV

8-bit field containing the current timer/register PLD revision. The revision number starts with 01.

6.2.13 PLD Data Code Register

The MVME3100 PLD provides a 32-bit register that contains the build date code of the timers/registers PLD.

Table 6-14 PLD Data Code Register

REG	PLD Data Code Register - 0xE200000C			
BIT	31:24	23:16	15:8	7:0
FIELD	yy	mm	dd	vv
OPER	R/W			
RESET	xxxx			

yy: Last two digits of the year

mm: Month

dd: Day

vv: Version

6.2.14 Test Register 1

The MVME3100 provides a 32-bit general-purpose read/write register that can be used by software for PLD test or general status bit storage.

Table 6-15 Test Register 1

REG	Test Register 1 - 0xE200010
BIT	31:0
FIELD	TEST1
OPER	R/W
RESET	0000

TEST1

General-purpose 32-bit read/write field.

6.2.15 Test Register 2

The MVME3100 provides a second 32-bit test register that reads back the complement of the data in test register 1.

Table 6-16 Test Register 2

REG	Test Register 2 - 0xE200014
BIT	31:0
FIELD	TEST2
OPER	R/W
RESET	FFFF

TEST2

A read from this address returns the complement of the data pattern in test register 1. A write to this address writes the uncomplemented data to register TEST1.

Memory Maps

6.2.16 External Timer Registers

The MVME3100 provides a set of tick timer registers for access to the four external timers implemented in the timers/registers PLD. These registers are 32-bit registers and are not byte writable. The following sections describe the external timer prescaler and control registers.

6.2.16.1 Prescaler Register

The prescaler provides the clock required by each of the four timers. The tick timers require a 1MHz clock input. The input clock to the prescaler is 25MHz. The default value is set for \$E7, which gives a 1MHz reference clock for a 25MHz input clock source.

Table 6-17 Prescaler Register

REG	Prescaler Register - 0xE2020000 (8 bits of 32)							
BIT	7	6	5	4	3	2	1	0
FIELD	Prescaler Adjust							
OPER	R/W							
RESET	\$E7							

Prescaler Adjust

The prescaler adjust value is determined by the following formula:

Prescaler adjust = $256 - (\text{CLKIN}/\text{CLKOUT})$ where CLKIN is the input clock source in MHz and CLKOUT is the desired output clock reference in MHz.

6.2.16.2 Control Registers

The prescaler provides the clock required by each of the four timers. The tick timers require a 1MHz clock input. The input clock to the prescaler is 25MHz. The default value is set for \$E7, which gives a 1MHz reference clock for a 25MHz input clock source.

Table 6-18 Tick Timer Control Registers

REG	Tick Timer 1 Control Register - 0xE2020010 (32 bits) Tick Timer 2 Control Register - 0xE2020020 (32 bits) Tick Timer 3 Control Register - 0xE2020030 (32 bits) Tick Timer 4 Control Register - 0xE2020040 (32 bits)													
BIT	31	...	11	10	9	8	7	6	5	4	3	2	1	0
FIELD	RSVD	:	RSVD	INTS	CINT	ENINT	OVF				RSVD	COVF	COC	ENC

Table 6-18 Tick Timer Control Registers (continued)

REG	Tick Timer 1 Control Register - 0xE2020010 (32 bits) Tick Timer 2 Control Register - 0xE2020020 (32 bits) Tick Timer 3 Control Register - 0xE2020030 (32 bits) Tick Timer 4 Control Register - 0xE2020040 (32 bits)													
OPER	R/W													
RESET	0	...	0	0	0	0	0	0	0	0	0	0	0	0

ENC

Enable counter. When this bit is high, the counter increments. When this bit is low, the counter does not increment.

Memory Maps

COC

Clear counter on compare. When this bit is high, the counter is reset to 0 when it compares with the compare register. When this bit is low, the counter is not reset.

COVF

Clear overflow bits. The overflow counter is cleared when a 1 is written to this bit.

OVF

Overflow bits. These bits are the output of the overflow counter. The overflow counter is incremented each time the tick timer sends an interrupt to the local bus interrupter. The overflow counter can be cleared by writing a 1 to the COVF bit.

ENINT

Enable interrupt. When this bit is high, the interrupt is enabled. When this bit is low, the interrupt is not enabled.

CINT

Clear interrupt.

INTS

Interrupt status.

RSVD

Reserved for future implementation.

6.2.16.3 Compare Registers

The tick timer counter is compared to the Compare register. When they are equal, the tick timer interrupt is asserted and the overflow counter is incremented. If the clear-on-compare mode is enabled, the counter is also cleared. For periodic interrupts, this equation should be used to calculate the compare register value for a specific period (T):

Compare register value = T (us)

When programming the tick timer for periodic interrupts, the counter should be cleared to zero by software and then enabled. If the counter does not initially start at 0, the time to the first interrupt may be longer or shorter than expected. The rollover time for the counter is 71.6 minutes.

Table 6-19 Tick Timer Compare Registers

Tick Timer 1 Compare Register - 0xE202 0014 (32 bits)			
Tick Timer 2 Compare Register - 0xE202 0024 (32 bits)			
Tick Timer 3 Compare Register - 0xE202 0034 (32 bits)			
Tick Timer 4 Compare Register - 0xE202 0044 (32 bits)			
BIT	31		0
FIELD	Tick Timer Compare Value		
OPER	R/W		
RESET	0		

6.2.16.4 Counter Registers

When enabled, the tick timer Counter register increments every microsecond. Software may read or write the counter at any time.

Table 6-20 Tick Timer Counter Registers

REG			
Tick Timer 1 Counter Register - 0xE202 0018 (32 bits)			
Tick Timer 2 Counter Register - 0xE202 0028 (32 bits)			
Tick Timer 3 Counter Register - 0xE202 0038 (32 bits)			
Tick Timer 4 Counter Register - 0xE202 0048 (32 bits)			
BIT	31		0
FIELD	Tick Timer Counter Value		
OPER	R/W		
RESET	0		

6.2.17 Geographical Address Register

The VMEbus Status register in the TSi148 provides the VMEbus geographical address of the MVME3100. This register reflects the inverted states of the geographical address pins at the 5-row, 160-pin P1 connector.

Memory Maps

Programming Details

7.1 Introduction

This chapter includes additional programming information for the MVME3100 single board computer. Items discussed include:

MPC8540 Reset Configuration

MPC8540 Interrupt Controller

Local Bus Controller Chip Select Assignments

Two-Wire Serial Interface

User Configuration EEPROM

VPD EEPROM

RTM VPD EEPROM

Ethernet PHY Address

Flash Memory

PCI IDSEL Definition

PCI Arbitration Assignments

Clock Distribution

MPC8540 Real-Time Clock Input

MPC8540 LBC Clock Divisor

7.2 MPC8540 Reset Configuration

The MVME3100 supports the power-on reset (POR) pin sampling method for MPC8540 reset configuration. The states of the various configuration pins on the MPC8540 are sampled when reset is deasserted to determine the desired operating modes. The following table describes the configuration options and the corresponding default setting. Refer to the *MPC8540 Reference Manual* listed in [Appendix 9, Related Documentation](#), for additional details and/or programming information.

Table 7-1 MPC8540 Power-on Reset Configuration Settings

MPC8540 Signal	Select Option	Default Setting	Description	State of Bit vs Function ¹	
PCI_REQ64_L	PLD logic	0	PCI-32 Configuration	0	PCI/PCI-X interface is 64-bit
				1	PCI/PCI-X interface is 32-bit
PCI_GNT1_L	Resistor	0	PCI Interface I/O Impedance	0	25 ohm drivers
				1	42 ohm drivers
PCI_GNT2_L	Resistor	1	PCI Arbiter Configuration	0	Disabled on-chip PCI/PCI-X arbiter ²
				1	Enabled on-chip PCI/PCI-X arbiter
PCI_GNT3_L	Resistor	1	PCI Debug Configuration	0	PCI debug enabled
				1	PCI operates in normal mode
PCI_GNT4_L	Switch	0	PCI/PCI-X Configuration	0	PCI-X mode
				1	PCI mode
EC_MDC	Resistor	1	TSEC Width Configuration	0	Ethernet in reduced mode (RTBI or RGMII)
				1	Ethernet in standard mode (TBI or GMII)

Table 7-1 MPC8540 Power-on Reset Configuration Settings (continued)

MPC8540 Signal	Select Option	Default Setting	Description	State of Bit vs Function ¹	
TSEC1_TXD7	Resistor	0	TSEC1 Protocol Configuration	0	TSEC1 controller uses GMII protocol (RGMII if TSEC1 configured in reduced mode)
				1	TSEC1 controller uses TBI protocol (RTBI if TSEC1 configured in reduced mode)
TSEC1_TXD [6:4]	Resistors	111	Boot ROM Location	000	PCI/PCI-X
				001	DDR SDRAM
				011	RapidIO
				101	Local Bus GPCM 8-bit ROM
				110	Local Bus GPCM 16-bit ROM
111	Local Bus GPCM 32-bit ROM				
TSEC2_TXD7	Resistor	0	TSEC2 Protocol Configuration	0	TSEC2 controller uses GMII protocol (or RGMII if TSEC2 configured in reduced mode)
				1	TSEC2 controller uses TBI protocol (or RTBI if TSEC2 configured in reduced mode)

Programming Details

Table 7-1 MPC8540 Power-on Reset Configuration Settings (continued)

MPC8540 Signal	Select Option	Default Setting	Description	State of Bit vs Function ¹	
TSEC2_TXD [6:5]	Resistors	11	Local Bus Output Hold Configuration	00	0 added buffer delays (0 added buffer delays for LALE)
				01	3 added buffer delays (1 added buffer delay for LALE)
				10	2 added buffer delays (1 added buffer delay for LALE)
				11	1 added buffer delay (0 added buffer delays for LALE)
TSEC2_TXD [2:4]	Fixed	000	RapidIO Device ID (3 lower-order bits)	000	Unconnected Inputs
LA27	Resistor	1	CPU Boot Configuration	0	CPU boot hold off mode ³
				1	e500 core boots without waiting for configuration by an external master

Table 7-1 MPC8540 Power-on Reset Configuration Settings (continued)

MPC8540 Signal	Select Option	Default Setting	Description	State of Bit vs Function ¹	
				Bit 1	Bit 0
LA [28:31]	PLD logic	0011 for 100 MHz PCI bus 0101 for 66 MHz PCI bus	CCB Clock PLL Ratio (CCB Clock: SYSCLK)	0000	16:1
				0010	2:1
				0011	3:1
				0100	4:1
				0101	5:1
				0110	6:1
				1000	8:1
				1001	9:1
				1010	10:1
1100	12:1				
LWE [0:1] _L 4	Resistors	11	PCI Output Hold Configuration	00	1 added buffer delay
				01	0 added buffer delays
				10	3 added buffer delays
				11	2 added buffer delays ⁵
		11	PCI-X Output Hold Configuration	00	3 added buffer delays
				01	2 added buffer delays
				10	1 added buffer delay
11	0 added buffer delays⁶				
LWE [2:3] _L	Resistors	11	MPC8540 Host/Agent Configuration	00	Agent of RapidIO and PCI/PCI-X
				01	Agent of a RapidIO
				10	Agent of a PCI/PCI-X
				11	Host of both RapidIO and PCI/PCI-X

Programming Details

Table 7-1 MPC8540 Power-on Reset Configuration Settings (continued)

MPC8540 Signal	Select Option	Default Setting	Description	State of Bit vs Function ¹	
				Bit	Function
LALE, LGPL2	Resistor	01	e500 Core Clock PLL Ratio (e500 Core: CCB Clock)	00	2:1
				01	5:2
				10	3:1
				11	7:2
LGPL0, LGPL1	Fixed	11	RapidIO Transmit Clock Source	00	Reserved
				01	RapidIO rcv clock is source of xmit clock
				10	RapidIO xmit clock inputs are source of xmit clock
				11	CCB clock is source of xmit clock
LGPL3, LGPL5	Fixed	11	Boot Sequencer Configuration	00	Reserved
				01	Boot sequencer enabled with normal I2C address mode
				10	Boot sequencer enabled with extended I2C address mode
				11	Boot sequencer disabled
LAD [28:31]	Resistor ⁷	XX	General-Purpose POR Configuration	XX	General-purpose POR configuration vector to be placed in CPPORCR register bits

Table 7-1 MPC8540 Power-on Reset Configuration Settings (continued)

MPC8540 Signal	Select Option	Default Setting	Description	State of Bit vs Function ¹	
MSRCID0	Resistor	1	Memory Debug Configuration	0	Debug info from the LBC is driven on MSRCID & MDVAL pins
				1	Debug info from the DDR SDRAM controller is driven on MSRCID & MDVAL pins
MSRCID1	Resistor	1	DDR Debug Configuration	0	Debug info on ECC pins instead of normal ECC ⁸
				1	ECC pins function in normal mode

NOTES:

1. The selected configuration settings are indicated by dark cell outlines.
2. External arbitration is required.
3. e500 core does not boot until configured by an external master.
4. Dependent on PCI/PCI-X mode configuration.
5. Required to meet 2 ns hold time requirement.
6. Meets 0.7 ns hold time requirement.
7. Local bus LAD[0:31] is sampled during POR, but only LAD[28:31] are configurable by resistor option. Software can use this value to inform the firmware or operating system about initial board configuration.
8. ECC signals from memory devices must be disconnected.

7.3 MPC8540 Interrupt Controller

The MVME3100 uses the MPC8540 integrated programmable interrupt controller (PIC) to manage locally generated interrupts. Currently defined external interrupting devices and interrupt assignments, along with corresponding edge/levels and polarities, are shown in the following table.

Table 7-2 MPC8540 Interrupt Controller

Interrupt #	Edge/Level	Polarity	Interrupt Source	Notes
0	Level	Low	VME0	
1	Level	Low	VME1/External Timers	1
2	Level	Low	VME2/sATA	
3	Level	Low	VME3/UARTs (OR'd)	2
4	Level	Low	PMCSpan/PMCs/USB	
5	Level	Low	PMCSpan/PMCs	
6	Level	Low	PMCSpan/PMCs	
7	Level	Low	PMCSpan/PMCs	
8	Level	Low	ABORT	
9	Level	Low	Temp Sensor	
10	Level	Low	Ethernet PHYs (OR'd)	
11	Level	Low	DS1375 Alarm Interrupt	

1. External timers are implemented in a PLD.

2. External UARTs are implemented using a QUART.

Refer to the *MPC8540 Reference Manual* listed in [Appendix 9, Related Documentation](#), for additional details regarding the operation of the MPC8540 PIC.

7.4 Local Bus Controller Chip Select Assignments

The following table shows local bus controller (LBC) bank and chip select assignments for the MVME3100 board.

Table 7-3 LBC Chip Select Assignments

LBC Bank/ Chip Select	Local Bus Function	Size	Data Bus Width	Notes
0	Boot Flash bank	32MB - 128MB	32 bits	1
1	Optional second Flash bank	32MB - 128MB	32 bits	1
2	Control/Status registers	64 KB	32 bits	2
3	Quad UART	64 KB	8 bits	
4	32-bit timers	64 KB	32 bits	3
5-7	Not used			

1. Flash bank size determined by VPD flash packet.

2. Control/Status registers are byte read and write capable.

3. 32-bit timer registers are byte readable, but must be written as 32 bits.

7.5 Two-Wire Serial Interface

A two-wire serial interface for the MVME3100 is provided by an I²C compatible serial controller integrated into the MPC8540. The MPC8540 I²C controller is used by the system software to read the contents of the various I²C devices located on the MVME3100. The following table contains the I²C devices used for the MVME3100 and their assigned device addresses.

Table 7-4 I²C Bus Device Addressing

I ² C Bus Address	Device Address A2 A1 A0 (binary)	Size (bytes)	Device Function	Notes
\$90	000	N/A	DS1621 temperature sensor	
\$A0	000	256 x 8	DDR memory SPD (SODIMM module banks 1 and 2 corresponding to MPC8540 memory controller chip selects 0 and 1)	1

Programming Details

Table 7-4 I2C Bus Device Addressing (continued)

I2C Bus Address	Device Address A2 A1 A0 (binary)	Size (bytes)	Device Function	Notes
\$A2	001		Reserved	
\$A4	010	65,536 x 8	User configuration	2
\$A6	011	65,536 x 8	User configuration	2
\$A8	100	8192 x 8	VPD (on-board system configuration)	2
\$AA	101	8192 x 8	RTM VPD (off-board configuration)	2, 3
\$AC	110		Reserved	
\$AE	111		Reserved	
\$D0	N/A	N/A	DS1375 real-time clock	

1. Each SPD defines the physical attributes of each bank or group of banks. If both banks of a SODIMM are populated they are the same speed and memory size.

2. This is a dual address serial EEPROM.

3. The device address is user selectable using switches on the RTM. The recommended address setting for the MVME3100 is \$AA.

7.6 User Configuration EEPROM

The MVME3100 board provides two 64KB dual address serial EEPROMs for a total of 128KB user configuration storage. These EEPROMs are hardwired to have device IDs as shown in [Table 7-4](#), and each device ID will not be used for any other function. Refer to the *2-Wire Serial EEPROM Data sheet* listed in [Appendix 9, Related Documentation](#), for additional details.

7.7 VPD EEPROM

The MVME3100 board provides an 8KB dual address serial EEPROM containing vital product data (VPD) configuration information specific to the MVME3100. Typical information that may be present in the EEPROM may include: manufacturer, board revision, build version, date of assembly, memory present, options present, L2 cache information, etc. The VPD EEPROM is hardwired to have a device ID as shown in [Table 7-](#)

4. Refer to the *2-Wire Serial EEPROM Data sheet* listed in [Appendix 9, Related Documentation](#), for additional details.

7.8 RTM VPD EEPROM

The MVME3100 board provides an 8KB dual address serial EEPROM containing VPD configuration information specific to the MVME3100 RTM. Typical information that may be present in the EEPROM may include: manufacturer, board revision, build version, date of assembly, options present, etc. The RTM VPD EEPROM device ID is user selectable with the recommended value for MVME3100 as shown in [Table 7-4](#). Refer to the *2-Wire Serial EEPROM Data sheet* listed in [Appendix 9, Related Documentation](#), for additional details.

7.9 Ethernet PHY Address

The assigned Ethernet PHY addresses on the MPC8540 MII management (MIIM) bus is shown in the following table.

Table 7-5 PHY Types and MII Management Bus Addresses

MPC8540 Ethernet Port	Function/Location	PHY Types	PHY MIIM Address [4:0]
TSEC1	Gigabit Ethernet port routed to front panel	BCM5461S	01
TSEC2	Gigabit Ethernet port routed to P2	BCM5461S	02
Fast Ethernet Controller	10/100 Ethernet port routed to P2	BCM5221	03

7.10 Flash Memory

The MVME3100 is designed to provide one or two physical banks of soldered-on flash memory. Each bank may be populated with two AMD Spansion MirrorBit 3.0V devices configured to operate in 16-bit mode to form a 32-bit flash bank. The flash bank connected to LBC Chip Select 0 is the boot bank and is always populated. The second flash bank connected to LBC Chip Select 1 may or may not be populated depending on flash size requirements and available flash devices. The VPD flash packet(s) will determine which banks are populated and the size of the devices. Software must program one or two LBC chip selects based on the VPD flash packet information. The following table defines the supported flash density options for each bank. The factory configuration for the MVME3100-1152 is one bank of 64MB and for the MVME3100-1263 it is one bank of 128MB.

Programming Details

Table 7-6 Flash Options

Flash Bank Size	Spansion Part Number	Device Size
32MB	S29GL128N	128 Mbit
64MB	S29GL256N	256 Mbit
128MB	S29GL512N	512 Mbit

A hardware flash bank write protect switch is provided on the MVME3100 to enable write protection of both physical banks. Regardless of the state of the software flash write protect bit in the Flash Control/Status register, write protection is enabled for both banks when this switch is ON. When this switch is OFF, write protection is controlled by the state of the software flash write protect bit and can only be disabled by clearing this bit in the Flash Control/Status register. Refer to [Flash Control/Status Register on page 108](#) for more information.

The F_WE_HW bit reflects the state of the switch and is only software readable, whereas the F_WP_SW bit supports both read and write operations.

The MVME3100 provides a dual boot option for booting from one of two separate boot images in the boot flash bank, which are referred to as boot block A and boot block B. Boot blocks A and B are each 1MB in size and are located at the top (highest address) 2MB of the boot flash memory space. Boot block A is located at the highest 1MB block and block B is the next highest 1MB block. A FLASH boot block switch is used to select between boot block A and boot block B. When the switch is OFF, the flash memory map is normal and block A is selected. When the switch is ON, block B is mapped to the highest address as shown below. The MAP_SEL bit in the Flash Control/Status register can override the switch and restore the memory map to the normal configuration with block A selected. Upon RESET, this mapping reverts to the switch selection.

7.11 PCI IDSEL Definition

Each PCI device has an associated address line connected via a resistor to its IDSEL pin for configuration space accesses. The following table shows the IDSEL assignments for the PCI devices and slots on each of the PCI buses on the board, along with the corresponding interrupt assignment to the PIC external interrupt pins. Refer to the *MPC8540 Reference Manual* and *PCI6520CB Data Book* and for details on generating configuration cycles on each of the PCI busses.

Table 7-7 IDSEL and Interrupt Mapping for PCI Devices

PCI Bus	Device Number Field	AD Line for IDSEL	PCI Device or Slot	Device/Slot INT to MPC8540 Ext IRQ			
				INTA#	INTB#	INTC#	INTD#
A (8540) (See Note following table)	0b0_0000	internal	MPC8540				
	0b0_0001	17	TSi148 VME	IRQ0	IRQ1	IRQ2	IRQ3
	0b0_0010	18	PCI6520-1				
	0b0_0011	19	PCI6520-2				
	0b0_0100	20	Sil3124A sATA	IRQ2			
B (PCI6520-1)	0b0_0000	16	PMC1 Primary	IRQ4	IRQ5	IRQ6	IRQ7
	0b0_0001	17	PMC1 Secondary	IRQ5	IRQ6	IRQ7	IRQ4
	0b0_0010	18	PMC2 Primary	IRQ6	IRQ7	IRQ4	IRQ5
	0b0_0011	19	PMC2 Secondary	IRQ7	IRQ4	IRQ5	IRQ6
C (PCI6520-2)	0b0_0000	16	uPD740101 USB	IRQ4	IRQ5	IRQ6	
	0b0_0100	20	21150 on PMCSpan				

Programming Details

Table 7-7 IDSEL and Interrupt Mapping for PCI Devices (continued)

PCI Bus	Device Number Field	AD Line for IDSEL	PCI Device or Slot	Device/Slot INT to MPC8540 Ext IRQ			
				INTA#	INTB#	INTC#	INTD#
PCI Expansion (21150)	0b0_0010	18	PMCSpan Slot 1	IRQ6	IRQ7	IRQ4	IRQ5
	0b0_0011	19	PMCSpan Slot 2	IRQ7	IRQ4	IRQ5	IRQ6
	0b0_0100	20	PMCSpan Slot 3	IRQ4	IRQ5	IRQ6	IRQ7
	0b0_0101	21	PMCSpan Slot 4	IRQ5	IRQ6	IRQ7	IRQ4

The Device Number is as listed when Bus A is in PCI-X mode. If Bus A is in PCI mode, add 0x16 (0b1_0000) to the listed Device Number.

The following table shows the Vendor ID and the Device ID for each of the planar PCI devices on the MVME3100.

Table 7-8 Planar PCI Device Identification

Function	Device	Vendor ID	Device ID
System Controller	MPC8540	0x1057	0x0008
PCI-X-to-PCI-X Bridge	PCI6520CB	0x10B5	0x6520
VME Controller	TSi148	0x10E3	0x0148
sATA Controller	Sil3124A	0x1095	0x3124
USB Controller	μPD720101	0x1033	0x0035

7.12 PCI Arbitration Assignments

The integrated PCI/X arbiters internal to the MPC8540 and the PCI6520 bridges provide PCI arbitration for the MVME3100. The MPC8540 provides arbitration support for itself and the four PCI-X devices on PCI bus A.

The PCI6520 secondary PCI/X interface arbiters support external bus masters in addition to the PCI6520. One secondary arbiter provides arbitration for the PMC sites on PCI bus B, and the other provides arbitration for the PMCspan and USB host controller on PCI bus C.

The arbitration assignments on the MVME3100 are shown in the follow table so that software may set arbiter priority assignments if necessary.

Table 7-9 PCI Arbitration Assignments

PCI Bus	Arbitration Assignment	PCI Master(s)
A	MPC8540 PCI_REQ/GNT[0]	SATA Controller
A	MPC8540 PCI_REQ/GNT[1]	TSI148 VME Controller
A	MPC8540 PCI_REQ/GNT[2]	PCI6520 (Bus A to Bus B bridge)
A	MPC8540 PCI_REQ/GNT[3]	PCI6520 (Bus A to Bus C bridge)
B	PCI6520-1 S_REQ/GNT[0]	PMC site 1 primary master
B	PCI6520-1 S_REQ/GNT[1]	PMC site 1 secondary master
B	PCI6520-1 S_REQ/GNT[2]	PMC site 2 primary master
B	PCI6520-1 S_REQ/GNT[3]	PMC site 2 secondary master
C	PCI6520-2 S_REQ/GNT[0]	USB Controller
C	PCI6520-2 S_REQ/GNT[1]	PMCspan

7.13 Clock Distribution

The clock function generates and distributes all of the clocks required for system operation. The clock tree is designed in such a manner as to maintain the strict edge-to-edge jitter and low clock-to-clock skew required by the devices. Additional clocks required by individual devices are generated near the devices using individual oscillators. [Clock Assignments on page 136](#) lists the clocks required on the MVME3100 along with their frequency and source. The clock tree A frequencies on bus A have a default configuration of 66MHz. The 33/66/100MHz clocks are dynamically configured at reset depending on the state of the PCIXCAP and M66EN pins on bus B.



The PCI clock trees A, B, and C are not required to be synchronized with each other.

Programming Details

Table 7-10 Clock Assignments

Device	Clock Signal(s)	Frequency (MHz)	Clock Tree Source	Qty	VIO
MPC8540	CLK_8540	66/100	A	1	3.3V
TSi148	CLK_VME	66/100	A	1	3.3V
sATA	CLK_SATA	66/100	A	1	3.3v
PCI6520 Primary	CLK_P2P_ABP	66/100	A	2	3.3V
	CLK_P2P_ACP				
PMC1	CLK_PMC1	33/66/100	B	1	3.3V
PMC2	CLK_PMC2	33/66/100	B	1	3.3V
PCI6520 Secondary	CLK_P2P_ABS	33/66/100	B	1	3.3V
	CLK_P2P_ACS	33	C	1	3.3V
USB	CLK_USB	33	C	1	3.3V
PMCSpan	CLK_SPAN	33	C	1	3.3V
MPC9855	CLK66	25	Oscillator	2	3.3V
BCM5461S	CLK25_25V_PHY	25	Oscillator/ Buffer	2	2.5V
BCM5221	CLK25_33V_PHY	25	Oscillator/ Buffer	1	3.3V
Control and Timers PLD	CLK25_33V_PLD	25	Oscillator/ Buffer	1	3.3V
	CLK_LBC	CCB_CLK/8 (333 MHz/8)	MPC8540	1	3.3V
QUART	CLK_UART	1.8432	Oscillator	1	3.3V
sATA	CLK25	25	Oscillator	1	3.3V
USB	CLK48	48	Oscillator	1	3.3V
RTC	CLK32	32.768 kHz	Crystal	1	3.3V

7.14 MPC8540 Real-Time Clock Input

The MPC8540 real-time clock (RTC) input is driven by a 1MHz clock generated by the control and timers PLD. This provides a fixed clock reference for the RTC that software can use as a known timing reference. To select this 1MHz clock as the RTC timer reference, software must set the SEL_TBCLK bit in the MPC8540 HID0 register.

7.15 MPC8540 LBC Clock Divisor

The MPC8540 LBC clock output is used by the control and timers PLD. The LBC clock is derived from a divide by 2, 4 or 8 ratio of the internal CCB (core complex bus) clock as determined by the clock ratio register (LCRR[CLKDIV]). For proper operation of the local bus, CLKDIV must be set for divide by 8, which is the default value. The software must leave this register configured for divide by 8 during initialization.

Specifications

A.1 Power Requirements

In its standard configuration, the MVME3100 requires +5V for operation. On-board converters supply the processor core voltage, +3.3V, +1.8V, and +2.5V. For any installed PMC card that requires +12V or -12V, these voltages must be supplied by the chassis.

The next table provides an estimate of the typical and maximum current required from each of the input supply voltages.

Table A-1 Current Requirements

Model	Power
MVME3100 No PMCs or peripherals attached	Typical: 4.5A (22.5W) @ +5.0V Maximum: 5.6A (28W) @ +5.0V

In a 3-row chassis, PMC current should be limited to 32 watts (total of both PMC slots). In a 5-row chassis, the PMC sites can support a total of 50 watts.

A.2 Environmental Specifications

This table lists the environmental specifications, along with the board dimensions.

Table A-2 MVME3100 Specifications

Characteristics	Specifications
Operating Temperature	0° to +55°C/32°F to 131°F or (inlet air temperature with forced air cooling)
Storage Temperature	-40° to +85°C/-40°F to 185°F
Relative Humidity	Operating: 5% to 90% non-condensing Non-operating: 5% to 90% non-condensing
Vibration	Operating: 6Gs RMS, 5-200Hz sine Non-operating: 6Gs RMS, 20-2000Hz random
Physical Dimensions	6U, 4HP wide (233.4mm x 160mm x 19.8mm) (9.2 in. x 6.3 in. x 0.8 in.)
Weight	468 g/16.5 oz. (IEEE handles)
MTBF	122,480 hours (calculated based on MIL-HDBK-217F Notice 1)

Specifications



Product Damage

High humidity and condensation on surfaces cause short circuits.

Do not operate the product outside the specified environmental limits. Make sure the product is completely dry and there is no moisture on any surface before applying power.

A.3 Thermally Significant Components

The following table summarizes components that exhibit significant temperature rises. These are the components that should be monitored in order to assess thermal performance. The table also supplies the component reference designator and the maximum allowable operating temperature.

You can find components on the board by their reference designators. Versions of the board that are not fully populated may not contain some of these components.

Table A-3 Thermally Significant Components

Reference Designator	Generic Description	Max. Allowable Component Temperature (Celsius)	Measurement Location
U1012	Processor	0°C to 105°C/32°F to 221°F	Junction
XU1	Memory	0°C to 70°C/32°F to 158°F	Ambient
U21	VME Bridge	0°C to 70°C/32°F to 158°F	Ambient
U1009, U1010	PCI Bridge	0°C to 70°C/32°F to 158°F	Ambient
U5000	SATA Controller	-0°C to 70°C/32°F to 158°F	Ambient
U1028, U1029	Gigabit Ethernet	0°C to 70°C/32°F to 158°F	Ambient
U1039	Ethernet 10/100 PHY	-40°C to 85°C/-40°F to 185°F	Ambient
U1051, U1052	Clock Driver	-40°C to 85°C/ -40°F to 185°F	Ambient
U1054	Programmable Logic Device	0°C to 85°C/ 32°F to 185°F	Junction

Figure A-1 Primary Side Components

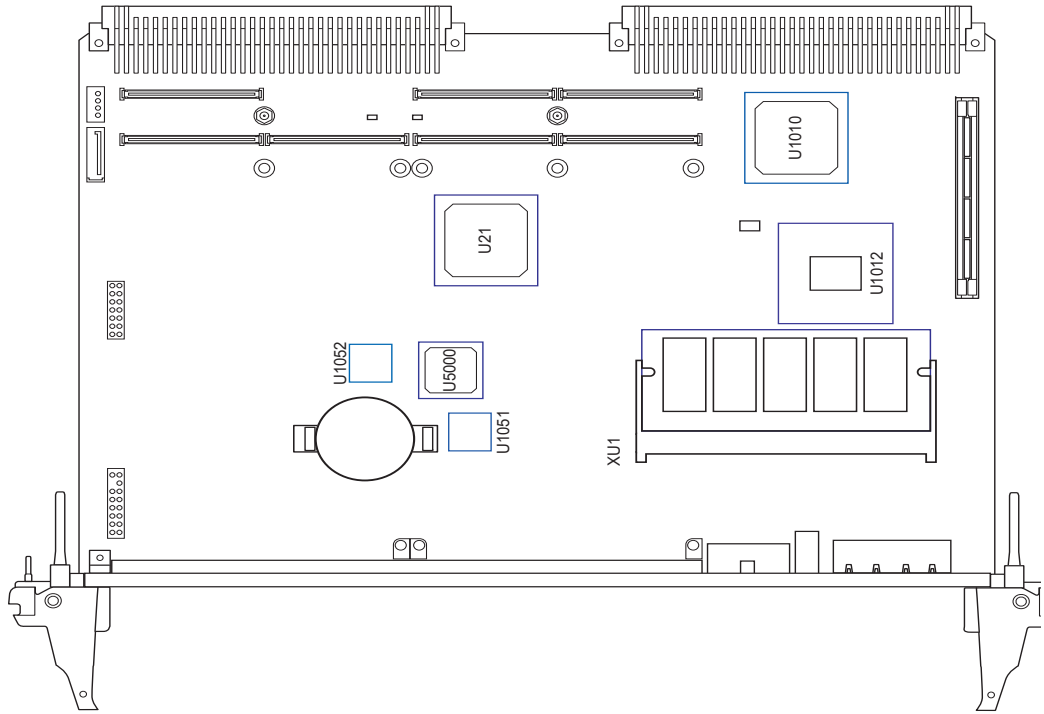

Specifications

The preferred measurement location for a component may be junction, case, or ambient as specified in the table. Junction temperature refers to the temperature measured by an on-chip thermal device. Case temperature refers to the temperature at the top, center surface of the component. Air temperature refers to the ambient temperature near the component.

Figure A-2 Secondary Side Components

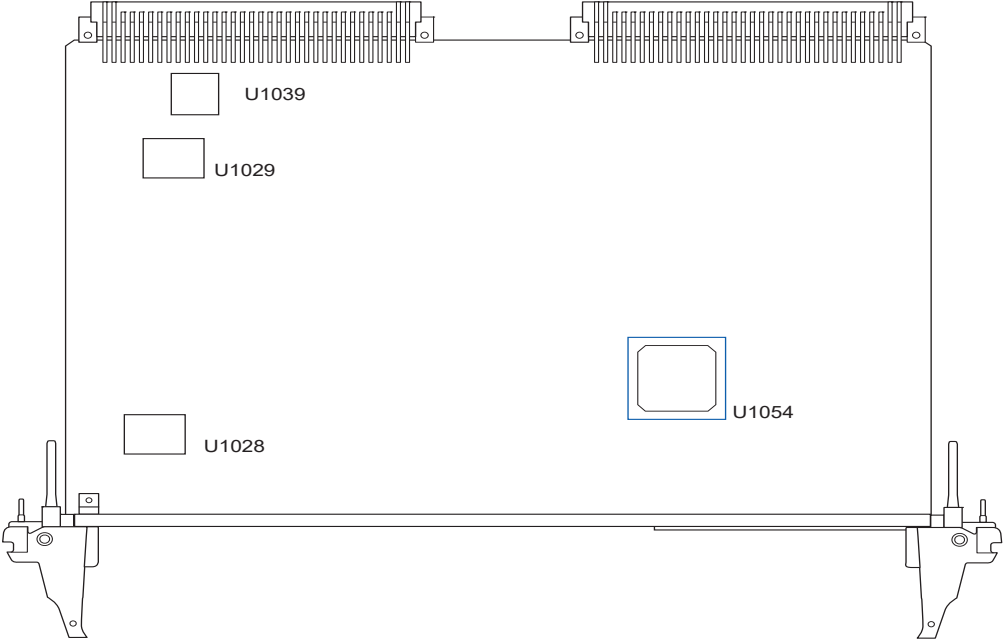

Related Documentation

B.1 Penguin Solutions Documentation

Technical documentation can be found by using the Documentation Search at <https://www.penguin-solutions.com/edge/support> or you can obtain electronic copies of documentation by contacting your local sales representative.

Table B-1 Penguin Edge Documents

Document Title	Document Number
MVME3100 Single-Board Computer Programmer's Reference Guide	6806800G37
MVME3100 NXP® MPC8540 VME SBC	MVME3100-DS
MOTLoad Firmware Package User's Manual	6806800C24
PMCspan PMC Adapter Carrier Board Installation and Use	6806800A59

B.2 Manufacturers' Documents

For additional information, refer to the following table for manufacturers' data sheets or user's manuals. As an additional help, a source for the listed document is provided. Please note that, while these sources have been verified, the information is subject to change without notice.

Table B-2 Manufacturers' Documents

Document Title and Source	Publication Number
MPC8540 Integrated Processor Hardware Specifications Web Site: www.nxp.com	MPC8540EC
MPC8540 PowerQUICC III™ Integrated Host Processor Reference Manual Web Site: www.nxp.com	MPC8540RM
Tsi148 PCI/X to VME Bus Bridge User Manual Web Site: www.idt.com	80A3020_MA001_02
BCM5421S 10/100/1000BASE-T Gigabit Transceiver Broadcom Corporation Web Site: www.broadcom.com	BCM5421
BCM5221S 10/100BASE-Tx Single-Channel Signi-PHY Transceiver Broadcom Corporation Web Site: www.broadcom.com	BCM5221

Related Documentation

Table B-2 Manufacturers' Documents (continued)

Document Title and Source	Publication Number
Sil3214A SATALink 4-Port PCI or PCI-X Host Controller Data Sheet Silicon Image Corporation Web Site: http://www.siliconimage.com/docs/Sil-DS-0160-C.pdf	Sil-DS-0160-C.pdf
S29GLxxxN MirrorBit™ Flash Family S29GL512N, S29GL256N, S29GL128N AMD, Inc. Web Site: www.amd.com/us-en/FlashMemory	27631 Revision A Amendment 3 May 13, 2004
mPD720101 USB 2.0 Host Controller Datasheet NEC Electronics Web Site: www.necel.com/usb/en/document/index.html	S16265EJ3V0DS00 April 2003
PCI6520CB Data Book PLX Technology, Inc. Web Site: www.plxtech.com	
EXAR ST16C554/554D, ST68C554 Quad UART with 16-Byte FIFOs Web Site: www.maxlinear.com	ST16C554/554D Rev. 3.1.0
2-Wire Serial EEPROM Microchip Corporation Web Site: www.microchip.com	AT24C512
Maxim DS1621 Digital Thermometer and Thermostat Maxim Integrated Products Web Site: www.maxim-ic.com	DS1621
Maxim DS1375 Serial Real-Time Clock Maxim Integrated Products Web Site: www.maxim-ic.com	Rev: 121203
TSOP Type I Shielded Metal Cover SMT Yamaichi Electronics USA Web Site: www.yeu.com	

B.3 Related Specifications

For additional information, refer to the following table for related specifications. As an additional help, a source for the listed document is provided. Please note that, while these sources have been verified, the information is subject to change without notice.

Table B-3 Related Specifications

Document Title and Source	Publication Number
VITA http://www.vita.com	
VME64 Specification	ANSI/VITA 1-1994
VME64 Extensions	ANSI/VITA 1.1-1997
2eSST Source Synchronous Transfer	VITA 2.0-2003
PCI Special Interest Group (PCI SIG) http://www.pcisig.com	
Peripheral Component Interconnect (PCI) Local Bus Specification, Revision 2.0, 2.1, 2.2	PCI Local Bus Specification
PCI-X Addendum to the PCI Local Bus Specification	Rev 1.0b
IEEE http://www.ieee.org	
IEEE - Common Mezzanine Card Specification (CMC) Institute of Electrical and Electronics Engineers, Inc.	P1386 Draft 2.0
IEEE - PCI Mezzanine Card Specification (PMC) Institute of Electrical and Electronics Engineers, Inc.	P1386.1 Draft 2.0
USB http://www.usb.org/developers/docs	
Universal Serial Bus Specification	Revision 2.0 April 27, 2000

Related Documentation

PENGUIN[™]

SOLUTIONS 

Penguin Solutions is a trade name used by SMART Embedded Computing, Inc., a wholly owned subsidiary of SMART Global Holdings, Inc. Penguin Edge is a trademark owned by Penguin Computing, Inc., a wholly owned subsidiary of SMART Global Holdings, Inc. All other logos, trade names, and trademarks are the property of their respective owners. ©2022 SMART Embedded Computing, Inc.